



82C08 CHMOS DYNAMIC RAM CONTROLLER

- 0 Wait State with INTEL μ Processors
- IAPX 286 } 82C08-20 20 MHz
(10, 8 MHz) } 82C08-16 16 MHz
IAPX 186/88 } 82C08-10 10 MHz
86/88 } 82C08-8 8 MHz
- Supports 64K and 256K DRAMs
(256K x 1 and 256K x 4 Organizations)
- Power Down Mode with Programmable
Memory Refresh using Battery Backup
- Directly Addresses and Drives up to
1 Megabyte without External Drivers
- Microprocessor Data Transfer and
Advance Acknowledge Signals
- Five Programmable Refresh Modes
- Automatic RAM Warm-up
- Pin-Compatible with 8208
- 48 Lead Plastic DIP; 68 Lead PLCC
(See Intel Packaging; Order Number: 231369-001)
- Compatible with Normal Modes of
Static Column and Riplemode DRAMs

The Intel 82C08 Dynamic RAM Controller is a CMOS, high performance, systems oriented, Dynamic RAM controller that is designed to easily interface 64K and 256K Dynamic RAMs to Intel and other microprocessors. The 82C08 also has a power down mode where only the refresh logic is activated using battery backup.

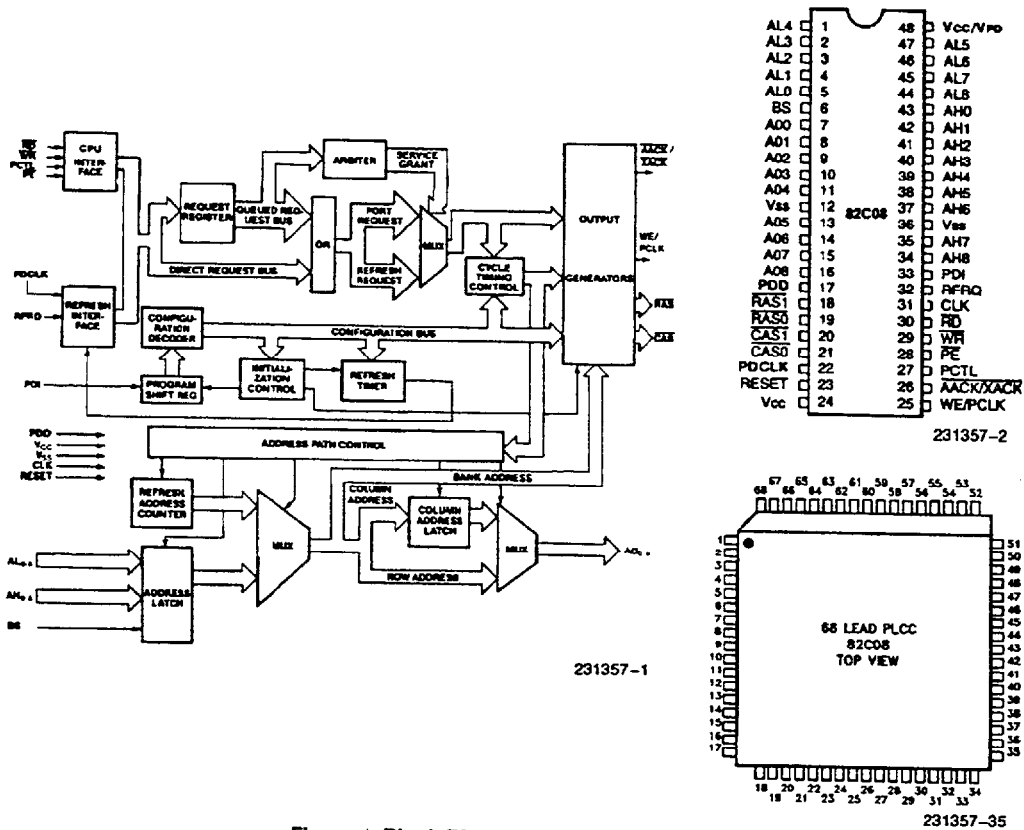

Figure 1. Block Diagram and Pinout Diagrams

Intel Corporation assumes no responsibility for the use of any circuitry other than circuitry embodied in an Intel product. No other circuit patent licenses are implied. Information contained herein supersedes previously published specifications on these devices from Intel.
 © INTEL CORPORATION, 1993
 September 1990
 Order Number: 231357-008

4826175 0176322 1T4

Table 1. Pin Description

Symbol	DIP Pin	PLCC	Type	Name and Function
AL0 AL1 AL2 AL3 AL4 AL5 AL6 AL7 AL8	5 4 3 2 1 47 46 45 44	55 56 57 58 59 63 64 66 67	 	ADDRESS LOW: These lower order address inputs are used to generate the column address for the internal address multiplexer. In iAPX 286 mode (CFS = 1), these addresses are latched internally.
AH0 AH1 AH2 AH3 AH4 AH5 AH6 AH7 AH8	43 42 41 40 39 38 37 35 34	2 3 4 5 6 7 8 12 13	 	ADDRESS HIGH: These higher order address inputs are used to generate the row address for the internal address multiplexer. In iAPX 286 mode, these addresses are latched internally.
BS	6	50		BANK SELECT: This input is used to select one of the two banks of the dynamic RAM array.
AO0 AO1 AO2 AO3 AO4 AO5 AO6 AO7 AO8	7 8 9 10 11 13 14 15 16	49 48 47 46 45 41 40 39 38	O O O O O O O O O	ADDRESS OUTPUTS: These outputs are designed to provide the row and column addresses, of either the CPU or the refresh counter, to the dynamic RAM array. These outputs drive the dynamic RAM array directly and need no external drivers. However, they typically need series resistors to match impedances.
RAS0 RAST	19 18	33 36	O O	ROW ADDRESS STROBE: These outputs are used by the dynamic RAM array to latch the row address, present on the AO0-8 pins. These outputs are selected by the BS pin. These outputs drive the dynamic RAM array directly and need no external drivers.
CAS0 CAST	21 20	30 31	O O	COLUMN ADDRESS STROBE: These outputs are used by the dynamic RAM array to latch the column address, present on the AO0-8 pins. These outputs are selected by the BS pin. These outputs drive the dynamic RAM array directly and need no external drivers.
RESET	23	28		RESET: This active high signal causes all internal counters to be reset. Upon release of RESET, data appearing at the PDI pin is clocked-in by the PCLK output. The states of the PDI, PCTL, and RFRQ pins are sampled by RESET going inactive and are used to program the 82C08. An 8-cycle dynamic RAM warm-up is performed after clocking PDI bits into the 82C08.
WE/ PCLK	25	24	O	WRITE ENABLE/PROGRAMMING CLOCK: Immediately after a RESET this pin becomes PCLK and is used to clock serial programming data into the PDI pin. After the 82C08 is programmed this active high signal provides the dynamic RAM array the write enable input for a write operation.

Table 1. Pin Description (Continued)

Symbol	DIP Pin	PLCC	Type	Name and Function
$\overline{\text{AACK}}$ / $\overline{\text{XACK}}$	26	23	O	ADVANCE ACKNOWLEDGE/TRANSFER ACKNOWLEDGE: When the X programming bit is set to logic 0 this pin is $\overline{\text{AACK}}$ and indicates that the processor may continue processing and that data will be available when required. This signal is optimized for the system by programming the S program-bit for synchronous or asynchronous operation. The S programming bit determines whether this strobe will be early or late. If another dynamic RAM cycle is in progress at the time of the new request, the $\overline{\text{AACK}}$ is delayed. When the X programming bit is set to logic 1 this pin is $\overline{\text{XACK}}$ and indicates that data on the bus is valid during a read cycle or that data may be removed from the bus during a write cycle. $\overline{\text{XACK}}$ is a MULTIBUS compatible signal.
PCTL	27	22	I	PORT CONTROL: This pin is sampled on the falling edge of RESET. It configures the 82C08 to accept command inputs or processor status inputs. If PCTL is low after RESET the 82C08 is programmed to accept bus/multibus command inputs or iAPX 286 status inputs. If PCTL is high after RESET the 82C08 is programmed to accept status inputs from iAPX 86 or iAPX 186 type processors. The S2 status line should be connected to this input if programmed to accept iAPX 86 or iAPX 186 inputs. When programmed to accept bus commands or iAPX 286 status inputs, it should be tied low or it may be connected to INHIBIT when operating with MULTIBUS.
PE	28	21	I	PORT ENABLE: This pin serves to enable a RAM cycle request. It is generally decoded from the address bus.
WR	29	20	I	WRITE: This pin is the write memory request command input. This input also directly accepts the $\overline{\text{S0}}$ status line from Intel processors.
RD	30	19	I	READ: This pin is the read memory request command pin. This input also directly accepts the $\overline{\text{S1}}$ status line from Intel processors.
CLK	31	16	I	CLOCK: This input provides the basic timing for sequencing the internal logic.
RFRQ	32	15	I	REFRESH REQUEST: This input is sampled on the falling edge of RESET. If RFRQ is high at RESET then the 82C08 is programmed for internal-refresh request or external-refresh request with failsafe protection. If RFRQ is low at RESET then the 82C08 is programmed for external-refresh without failsafe protection or burst refresh. Once programmed the RFRQ pin accepts signals to start an external-refresh with failsafe protection or external-refresh without failsafe protection or a burst refresh. RFRQ is also sampled when PDD is activated. When RFRQ = 1 it will cause 3 burst refresh cycles.
PDI	33	14	I	PROGRAM DATA INPUT: This input is sampled by RESET going low. It programs the various user selectable options in the 82C08. The PCLK pin shifts programming data into the PDI input from an external shift register. This pin may be strapped low to a default iAPX 186 mode configuration or high to a default iAPX 286 mode configuration.
*PDD	17	37	I	POWER DOWN DETECT: This input is sampled before every memory cycle to inform the 82C08 of system detection of power failure. When active, the 82C08 remains in power down mode and performs memory refresh only (RAS-only refresh). In power down mode the 82C08 uses PDCLK for timing and VPD for power.

4826175 0176324 T77

Table 1. Pin Description (Continued)

Symbol	DIP Pin	PLCC	Type	Name and Function
*PDCLK	22	29	I	POWER DOWN CLOCK: This pin is used as a clock for internal refresh circuits during power down. The input can be asynchronous to pin 31. Extended refresh is achieved by slowing down this clock. This pin should be grounded if not used.
*V _{CC} /V _{PD}	48	61, 62	I	POWER: Power supply for internal logic. This should be held active during power down, and normal operation.
V _{CC}	24	26, 27	I	POWER: Supply for drivers. Need not be held active during power down.
V _{SS}	12 36	9, 10, 11, 42, 43, 44	I I	GROUND GROUND
NC	—	17, 18, 1, 25, 32, 34, 35, 51, 53, 54, 60, 65, 68		
V _{CCS}		52		Connect to V _{PD} , Pins 61–62 for PLCC package.

*Different function than the HMOS 8208.

GENERAL DESCRIPTION

The Intel 82C08 Dynamic RAM Controller is a micro-computer peripheral device which provides the necessary signals to address, refresh, and directly drive 64K and 256K dynamic RAMs. It is compatible with static column or ripple mode DRAMs in the normal mode. It does not support the fast transfer mode of these DRAMs.

The 82C08 supports several microprocessor interface options including synchronous and asynchronous operations for iAPX 86, iAPX 186, iAPX 286, and MULTIBUS. The 82C08 will also interface to non-Intel microprocessors.

The 82C08 is a CHMOS version of the 8208 and is pin compatible with it. Three pins—17, 22, and 48—of the 82C08 are different from the 8208. They provide a power down mode that allows the system to run at a much lower I_{CC}. In this mode, the 82C08 refreshes the DRAM using battery backup. The power down current (I_{PD}) that is drawn by the 82C08 is very small compared to the I_{CC} which allows memory to be kept alive with a battery. A separate refresh clock, pin 22, allows the designer to take advantage of RAMs that permit extended memory refresh.

The 82C08 also has some timing changes versus the 8208. In order to eliminate the external bus latches, both WE and CAS timings are shortened. These timing changes are backwards-compatible for 8208 designs.

FUNCTIONAL DESCRIPTION

Processor Interface

The 82C08 has control circuitry capable of supporting one of several possible bus structures. The 82C08 may be programmed to run synchronous or asynchronous to the processor clock. The 82C08 has been optimized to run synchronously with Intel's iAPX 86, iAPX 88, iAPX 186/188 and iAPX 286. When the 82C08 is programmed to run in asynchronous mode, the 82C08 inserts the necessary synchronization circuitry for the RD, WR inputs.

The 82C08 achieves high performance (i.e. no wait states) by decoding the status lines directly from the processor. The 82C08 can also be programmed to receive read or write MULTIBUS commands or commands from a bus controller.

The 82C08 may be programmed to operate synchronously to the processor. It can also be programmed to run at various frequencies. (See Microprocessor Clock Frequency Option.)

Figure 2 shows the different processor interfaces to the 82C08 using the synchronous or asynchronous mode and status or command interface. Figure 3 shows detailed interfaces to the iAPX 186 and iAPX 286 processors.

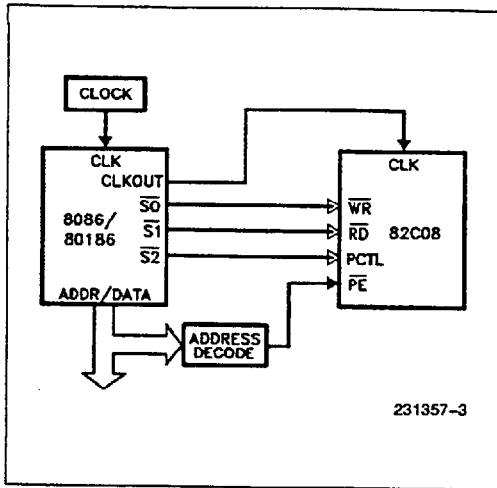

Slow-Cycle Synchronous-Status Interface

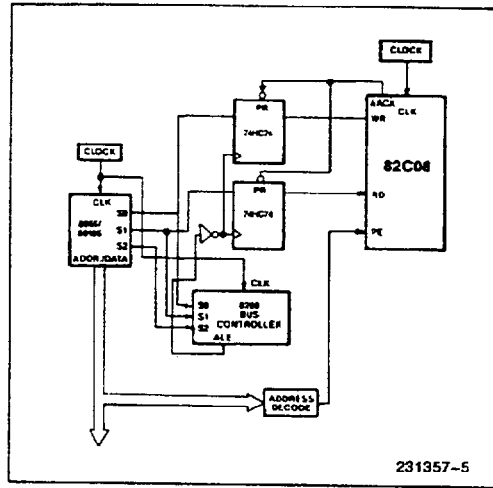

Slow-Cycle Asynchronous-Status Interface

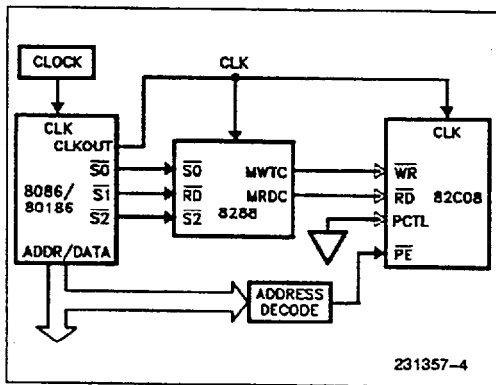

Slow-Cycle Synchronous-Command Interface

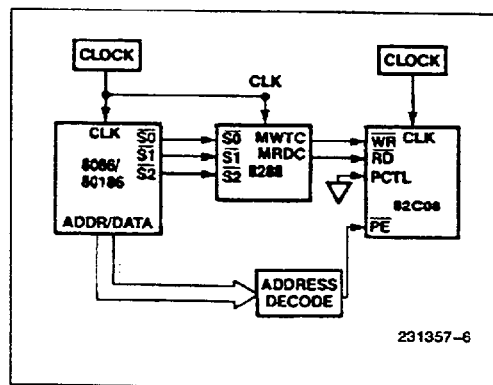

Slow-Cycle Asynchronous-Command Interface

Figure 2A. Slow-cycle (CFS = 0) Port Interfaces Supported by the 82C08

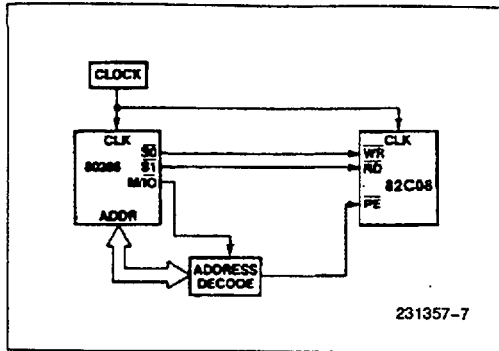

Fast-Cycle Synchronous-Status Interface

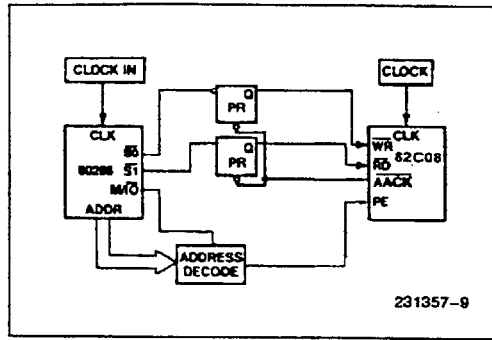

Fast-Cycle Asynchronous-Status Interface

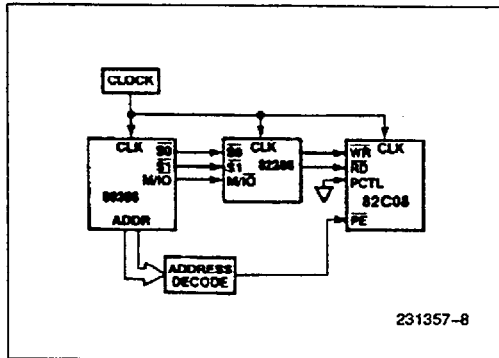

Fast-Cycle Synchronous-Command Interface

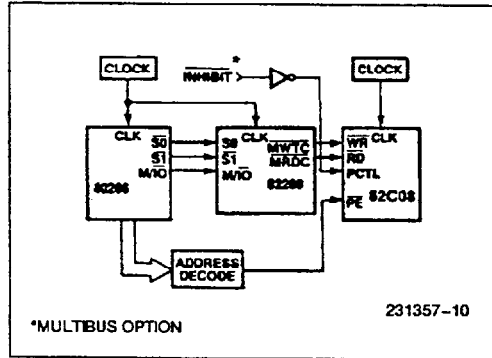

Fast-Cycle Asynchronous-Command Interface

Figure 2B. Fast-cycle (CFS = 1) Port Interfaces Supported by the 82C08

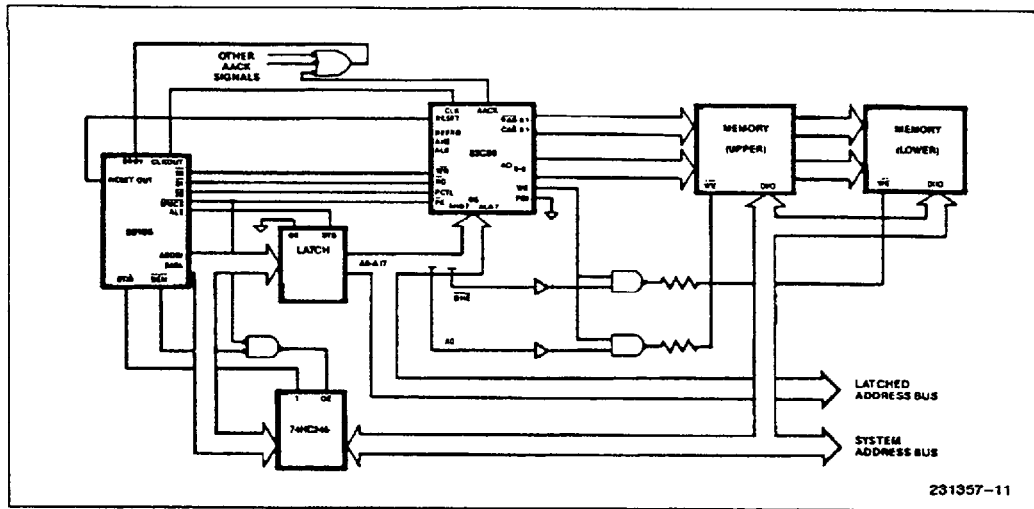

Figure 3A. 82C08 interface to an 80186

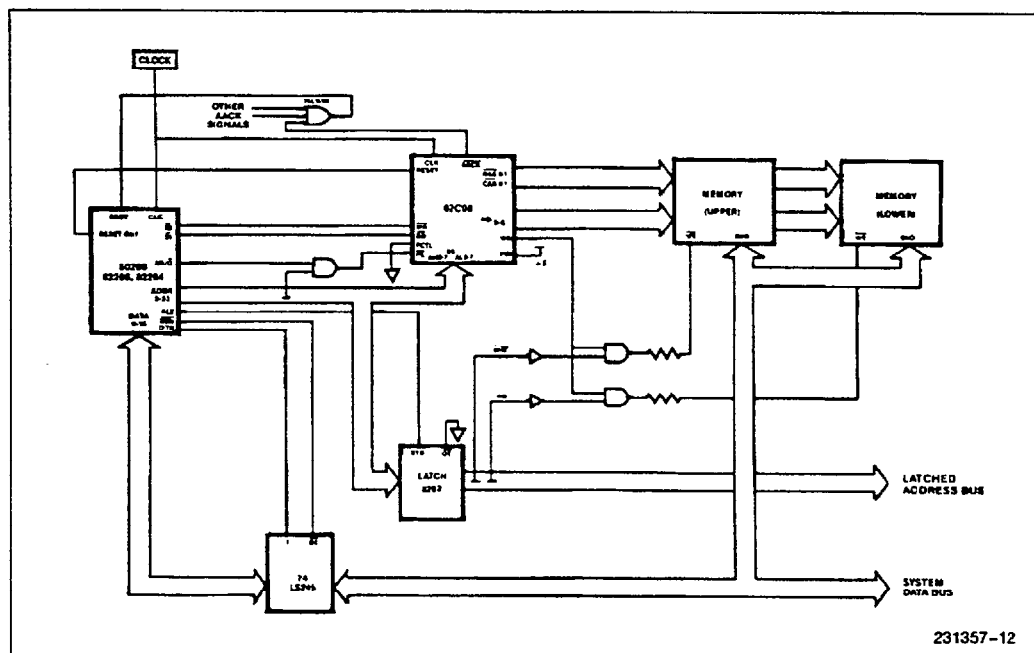

Figure 3B. 82C08 interface to an 80286

Dynamic RAM Interface

The 82C08 is capable of addressing 64K and 256K dynamic RAMs. Figure 3 shows the connection of the processor address bus to the 82C08 using the different RAMs.

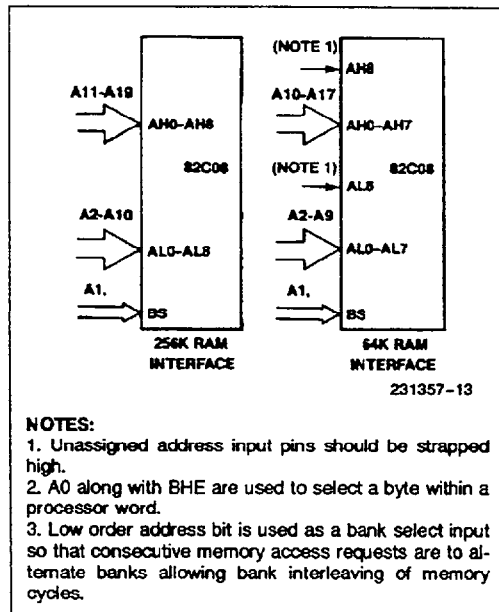

Figure 3. Processor Address Interface to the 82C08 Using 64K, and 256K RAMs

The 82C08 divides memory into two banks, each bank having its own Row (\overline{RAS}) and Column (\overline{CAS}) Address Strobe pair. This organization permits RAM cycle interleaving. RAM cycle interleaving overlaps the start of the next RAM cycle with the RAM pre-charge period of the previous cycle. Hiding the pre-charge period of one RAM cycle behind the data access period of the next RAM cycle optimizes memory bandwidth and is effective as long as successive RAM cycles occur in the alternate banks.

Successive data access to the same bank cause the 82C08 to wait for the precharge time of the previous RAM cycle. But when the 82C08 is programmed in an iAPX 186 synchronous configuration, consecutive cycles to the same bank do not result in additional wait states (i.e. 0 wait state).

If not all RAM banks are occupied, the 82C08 can be programmed to reassign the \overline{RAS} and \overline{CAS} strobes to allow using wider data words without increasing the loading on the \overline{RAS} and \overline{CAS} drivers.

Table 2 shows the bank selection decoding and the corresponding \overline{RAS} and \overline{CAS} assignments. For example, if only one RAM bank is occupied, then the two \overline{RAS} and \overline{CAS} strobes are activated with the same timing.

Table 2. Bank Selection Decoding and Word Expansion

Program Bit RB	Bank Input BS	82C08 $\overline{RAS}/\overline{CAS}$ Pair Allocation
0	0	$\overline{RAS}_{0,1}, \overline{CAS}_{0,1}$ to Bank 0
0	1	Illegal
1	0	$\overline{RAS}_0, \overline{CAS}_0$ to Bank 0
1	1	$\overline{RAS}_1, \overline{CAS}_1$ to Bank 1

Program bit RB is not used to check the bank select input BS. The system design must protect from accesses to "illegal", non-existent banks of memory by deactivating the PE input when addressing an "illegal", non-existent bank of memory.

The 82C08 adjusts and optimizes internal timings for either the fast or slow RAMs as programmed. (See RAM Speed Option.)

Memory Initialization

After programming, the 82C08 performs eight RAM "wake-up" cycles to prepare the dynamic RAM for proper device operation.

Refresh

The 82C08 provides an internal refresh interval counter and a refresh address counter to allow the 82C08 to refresh memory. The 82C08 has a 9-bit internal refresh address counter which will refresh 128 rows every 2 milliseconds, 256 rows every 4 milliseconds or 512 rows every 8 milliseconds, which allows all RAM refresh options to be supported. In addition, there exists the ability to refresh 256 row address locations every 2 milliseconds via the Refresh Period programming option.

The 82C08 may be programmed for any of five different refresh options: Internal refresh only, External refresh with failsafe protection, External refresh without failsafe protection, Burst refresh modes, or no refresh. (See Refresh Options.)

It is possible to decrease the refresh time interval by 10%, 20% or 30%. This option allows the 82C08 to compensate for reduced clock frequencies. Note

that an additional 5% interval shortening is built-in in all refresh interval options to compensate for clock variations and non-immediate response to the internally generated refresh request. (See Refresh Period Options.)

External Refresh Requests after RESET

External refresh requests are not recognized by the 82C08 until after it is finished programming and preparing memory for access. Memory preparation includes 8 RAM cycles to prepare and ensure proper dynamic RAM operation. The time it takes for the 82C08 to recognize a request is shown below.

eg. 82C08 System Response:

$$TRESP = TPROG + TPREP$$

where: TPROG = (40) (TCLCL) programming time

$$TPREP = (8) (32) (TCLCL) \text{ RAM}$$

warm-up time

$$\text{if } TCLCL = 125 \text{ ns then } TRESP = 37 \mu\text{s}$$

Reset

RESET is an asynchronous input, its falling edge is used by the 82C08 to directly sample the logic levels of the PCTL, RFRQ, and PDI inputs. The internally synchronized falling edge of reset is used to begin programming operations (shifting in the contents of the external shift register, if needed, into the PDI input).

Differentiated reset is unnecessary when the default synchronization programming is used.

Until programming is complete the 82C08 latches but does not respond to command or status inputs. A problem may occur if the S bit is programmed inconsistently from the Command which was latched before programming was completed. A simple means of preventing commands or status from occurring during this period is to differentiate the system reset pulse to obtain a smaller reset pulse for the 82C08.

The differentiated reset pulse would be shorter than the system reset pulse by at least the programming period required by the 82C08. The differentiated reset pulse first resets the 82C08, and system reset would reset the rest of the system. While the rest of the system is still in reset, the 82C08 completes its programming. Figure 4 illustrates a circuit to accomplish this task.

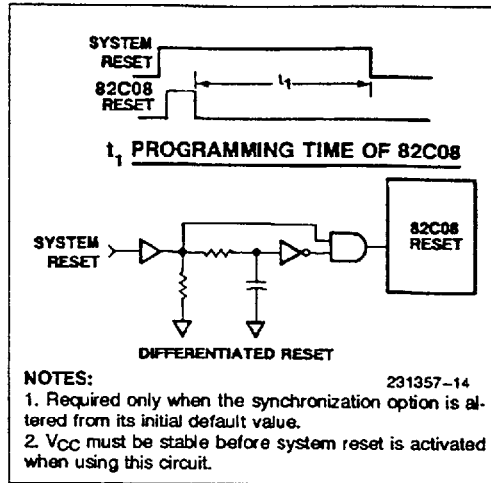

NOTES: 231357-14
 1. Required only when the synchronization option is altered from its initial default value.
 2. V_{CC} must be stable before system reset is activated when using this circuit.

Figure 4. 82C08 Differentiated Reset Circuit

Within four clocks after RESET goes active, all the 82C08 outputs will go high, except for AO0-2, which will go low.

OPERATIONAL DESCRIPTION

Programming the 82C08

The 82C08 is programmed after reset. On the falling edge of RESET, the logic states of several input pins are latched internally. The falling edge of RESET actually performs the latching, which means that the logic levels on these inputs must be stable prior to that time. The inputs whose logic levels are latched at the end of reset are the PCTL, RFRQ, and PDI pins.

Status/Command Mode

The processor port of the 82C08 is configured by the states of the PCTL pin. Which interface is selected depends on the state of the PCTL pin at the end of reset. If PCTL is high at the end of reset, the 8086/80186 Status interface is selected; if it is low, then the MULTIBUS or Command interface is selected.

The status lines of the 80286 are similar in code and timing to the Multibus command lines, while the status code and timing of the 8086 and 8088 are identical to those of the 80186 and 80188 (ignoring the differences in clock duty cycle). Thus there exists two interface configurations, one for the 80286 status or Multibus memory commands, which is called the Command interface, and one for 8086,

8088, 80186 or 80188 status, called the 8086 Status interface. The Command interface can also directly interface to the command lines of the bus controllers for the 8086, 8088, 80186 and the 80286.

The 80186 Status interface allows direct decoding of the status lines for the iAPX 86, iAPX 88, iAPX 186 and the iAPX 188. Table 3 shows how the status lines are decoded.

Table 3A. Status Coding of 8086, 80186 and 80286

Status Code			Function	
S2	S1	S0	8086/80186	80286*
0	0	0	INTERRUPT	INTERRUPT
0	0	1	I/O READ	I/O READ
0	1	0	I/O WRITE	I/O WRITE
0	1	1	HALT	IDLE
1	0	0	INSTRUCTION FETCH	HALT
1	0	1	MEMORY READ	MEMORY READ
1	1	0	MEMORY WRITE	MEMORY WRITE
1	1	1	IDLE	IDLE

* Refer to 80286 pin description table

Table 3B. 82C08 Response

82C08 Command			Function	
PCTL	RD	WR	8086/80186 Status Interface	80286 Status or Command Interface
0	0	0	IGNORE	IGNORE*
0	0	1	IGNORE	READ
0	1	0	IGNORE	WRITE
0	1	1	IGNORE	IGNORE
1	0	0	READ	IGNORE
1	0	1	READ	INHIBIT
1	1	0	WRITE	INHIBIT
1	1	1	IGNORE	IGNORE

*Illegal with CFS = 0

Refresh Options

Immediately after system reset, the state of the RFRQ input pin is examined. If RFRQ is high, the 82C08 provides the user with the choice between self-refresh and user-generated refresh with failsafe protection. Failsafe protection guarantees that if the user does not come back with another refresh request before the internal refresh interval counter times out, a refresh request will be automatically

generated. If the RFRQ pin is low immediately after a reset, then the user has the choice of a single external refresh cycle without failsafe, burst refresh or no refresh.

Internal Refresh Only

For the 82C08 to generate internal refresh requests, it is necessary only to strap the RFRQ input pin high.

External Refresh with Failsafe

To allow user-generated refresh requests with failsafe protection, it is necessary to hold the RFRQ input high until after reset. Thereafter, a low-to-high transition on this input causes a refresh request to be generated and the internal refresh interval counter to be reset. A high-to-low transition has no effect on the 82C08. A refresh request is not recognized until a previous request has been serviced.

External Refresh without Failsafe

To generate single external refresh requests without failsafe protection, it is necessary to hold RFRQ low until after reset. Thereafter, bringing RFRQ high for one clock period will cause a refresh request to be generated. A refresh request is not recognized until a previous request has been serviced.

Burst Refresh

Burst refresh is implemented through the same procedure as a single external refresh without failsafe (i.e., RFRQ is kept low until after reset). Thereafter, bringing RFRQ high for at least two clock periods will cause a burst of up to 128 row address locations to be refreshed. A refresh request is not recognized until a previous request has been serviced (i.e. burst is completed).

No Refresh

It is necessary to hold RFRQ low until after reset. This is the same as programming External Refresh without Failsafe. No refresh is accomplished by keeping RFRQ low.

Option Program Data Word

PROGRAMMING FOR SLOW CYCLE

The program data word consists of 9 program data bits, PDO-PD8. If the first program data bit, PDO is

set to logic 0, the 82C08 is configured to support iAPX 186, 188, 86, or 88 systems. The remaining bits, PD1-PD8, may then be programmed to optimize a selected system configuration. A default of all zeros in the remaining program bits optimizes the 82C08 timing for 8 MHz Intel CPUs using 150 ns (or faster) dynamic RAMs with no performance penalty.

PROGRAMMING FOR FAST CYCLE

If the first program data bit is set to logic 1, the 82C08 is configured to support iAPX 286 systems (Command mode). A default of all ones in the program bits optimizes the 82C08 timing for an 8 MHz 286 using 120 ns DRAMs at zero wait states. Note that the programming bits PD1-8 change polarity according to PD0. This ensures the same choice of options for both default modes.

Table 4A shows the various options that can be programmed into the 82C08.

Table 4A. Program Data Word

Program Data Bit	Name		Polarity/Function
	PD0 = 0	PD0 = 1	
PD0	CFS	CFS	CFS = 0 SLOW CYCLE CFS = 1 FAST CYCLE
PD1	S	S	S = 0 SYNCHRONOUS* S = 1 ASYNCHRONOUS
PD2	RFS	RFS	RFS = 0 FAST RAM* RFS = 1 SLOW RAM
PD3	RB	RB	RAM BANK OCCUPANCY SEE TABLE 2
PD4	CI1	CI1	COUNT INTERVAL BIT 1; SEE TABLE 6
PD5	CI0	CI0	
PD6	PLS	PLS	PLS = 0 LONG REFRESH PERIOD* PLS = 1 SHORT REFRESH PERIOD
PD7	FFS	FFS	FFS = 0 FAST CPU FREQUENCY* FFS = 1 SLOW CPU FREQUENCY
PD8	X	X̄	X = 0 AACK* X = 1 XACK

* Default in both modes

Using an External Shift Register

The 82C08 may be programmed by using an external shift register with asynchronous load capability

such as a 74HC165. The reset pulse serves to parallel load the shift register and the 82C08 supplies the clocking signal (PCLK) to shift the data into the PDI programming pin. Figure 6 shows a sample circuit diagram of an external shift register circuit.

Serial data is shifted into the 82C08 via the PDI pin (33), and clock is provided by the WE/PCLK pin (25), which generates a total of 9 clock pulses.

WE/PCLK is a dual function pin. During programming, it serves to clock the external shift register, and after programming is completed, it reverts to the write enable RAM control output pin. As the pin changes state to provide the write enable signal to the dynamic RAM array, it continues to clock the shift register. This does not present a problem because data at the PDI pin is ignored after programming. Figure 7 illustrates the timing requirements of the shift register.

Default Programming Options

After reset, the 82C08 serially shifts in a program data word via the PDI pin. This pin may be strapped low or high, or connected to an external shift register. Strapping PDI low causes the 82C08 to default to the iAPX 186 system configuration, while high causes a default to the iAPX 286 configuration. Table 4B shows the characteristics of the default configuration for Fast Cycle (PDI = 1) and Slow Cycle (PDI = 0). If further system flexibility is needed, one external shift register, like a 74HC165, can be used to tailor the 82C08 to its operating environment.

Table 4B. Default Programming

Synchronous interface
Fast RAM (Note 1)
2 RAM banks occupied
128 row refresh in 2 ms; 256 in 4 ms, 512 in 8 ms
Fast processor clock frequency
Advanced ACK strobe

NOTE:

1. For iAPX 86/186 systems either slow or fast (150 or 100 ns) RAMs will run at 8 MHz with zero wait states.

Synchronous/Asynchronous Mode (S program bit)

The 82C08 may be configured to accept synchronous or asynchronous commands (RD, WR, PCTL) and Port Enable (PE) via the S program bit. The state of the S programming bit determines whether the interface is synchronous or asynchronous.

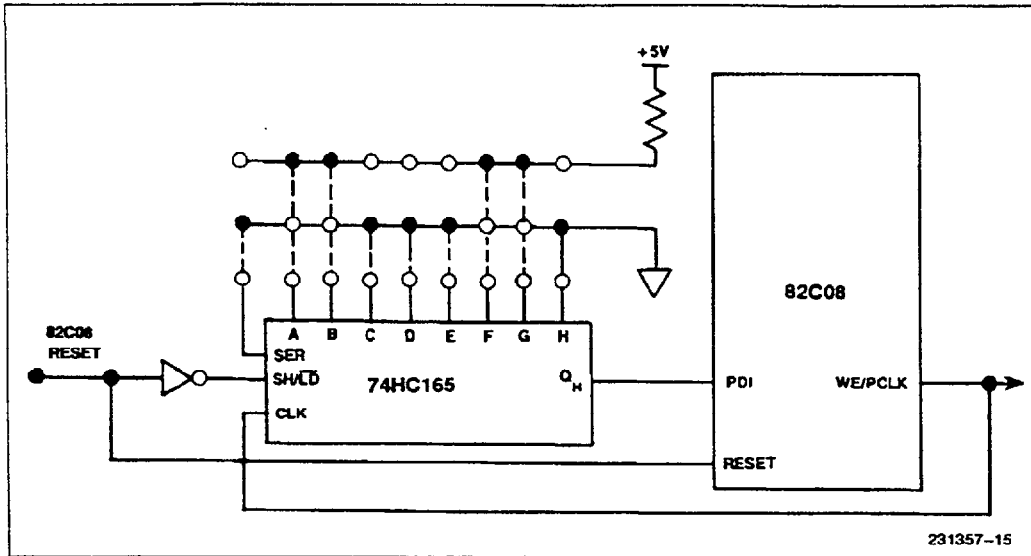
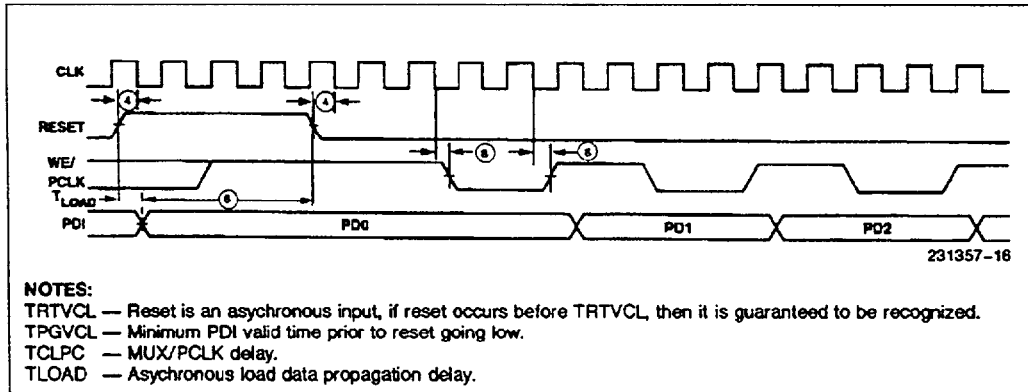

Figure 6. External Shift Register Interface



NOTES:
 TRTVCL — Reset is an asynchronous input, if reset occurs before TRTVCL, then it is guaranteed to be recognized.
 TPGVCL — Minimum PDI valid time prior to reset going low.
 TCLPC — MUX/PCLK delay.
 TLOAD — Asynchronous load data propagation delay.

Figure 7. Timing Illustrating External Shift Register Requirements for Programming the 82C08

While the 82C08 may be configured with either the Status or Command (MULTIBUS) interface in the Synchronous mode, certain restrictions exist in the Asynchronous mode. An Asynchronous-Command interface is directly supported. An Asynchronous-80186/80286 Status interface using the status lines of the 80186/80286 is supported with the use of TTL gates as illustrated in Figure 2. In the 80186 case, the TTL gates are needed to guarantee that status does not appear at the 82C08's inputs too much before address, so that a cycle would start before address was valid. In the case of the 80286, the TTL gates are used for lengthening the Status pulse, as required by the TRWL timing.

Microprocessor Clock Cycle Option (CFS and FFS program bits)

The 82C08 is programmed to interface with microprocessors with "slow cycle" timing like the 8086, 8088, 80186, and 80188, and with "fast cycle" microprocessors like the 80286. The CFS bit is used to select the appropriate timing.

The FFS option is used to select the speed of the microprocessor clock. Table 5 shows the various microprocessor clock frequency options that can be programmed. The external clock frequency must be

programmed so that the failsafe refresh repetition circuitry can adjust its internal timing accordingly to produce a refresh request as programmed.

Table 5. Microprocessor Clock Frequency Options

Program Bits		Processor	Clock Frequency
CFS	FFS		
0	0	iAPX 86, 88, 186, 188	≤ 5 MHz
0	1	iAPX 86, 88, 186, 188	> 5 MHz
1	0	iAPX 286	≤ 10 MHz
1	1	iAPX 286	> 10 MHz

RAM Speed Option (RFS program bit)

The RAM Speed programming option determines whether RAM timing will be optimized for a fast or slow RAM. Whether a RAM is fast or slow is measured relative to 100 ns DRAMs (fast) or 150 ns DRAMs (slow). This option is only a factor in Fast cycle Mode (CFS = 1).

Refresh Period Options (CI0, CI1 and PLS program bits)

The 82C08 refreshes with either 128 rows every 2 milliseconds, with 256 rows every 4 milliseconds or 512 rows every 8 milliseconds. This translates to one refresh cycle being executed approximately once every 15.6 microseconds. This rate can be changed to 256 rows every 2 milliseconds or a refresh approximately once every 7.8 microseconds via the Period Long/Short, program bit PLS, programming option.

The Count Interval 0 (CI0) and Count Interval 1 (CI1) programming options allow the rate at which refresh requests are generated to be increased in order to permit refresh requests to be generated close to the 15.6 or 7.8 microsecond period when the 82C08 is operating at reduced frequencies. The interval between refreshes is decreased by 0%, 10%, 20%, or 30% as a function of how the count interval bits are programmed. A 5% guardband is built-in to allow for any clock frequency variations. Table 6 shows the refresh period options available.

The numbers tabulated under Count Interval represent the number of clock periods between internal refresh requests. The percentages in parentheses represent the decrease in the interval between refresh requests.

Table 6. Refresh Count Interval Table

Ref. Period (μs)	CFS	PLS	FFS	Count Interval CI1, CI0 (82C08 Clock Periods)			
				00 (0%)	01 (10%)	10 (20%)	11 (30%)
15.6	1	1	1	236	212	188	164
7.8	1	0	1	118	106	94	82
15.6	1	1	0	148	132	116	100
7.8	1	0	0	74	66	58	50
15.6	0	1	1	118	106	94	82
7.8	0	0	1	59	53	47	41
15.6	0	1	0	74	66	58	50
7.8	0	0	0	37	33	29	25

The refresh count interval is set up for the following basic frequencies:

- 5 MHz slow cycle
- 8 MHz slow cycle
- 10 MHz fast cycle
- 16 MHz fast cycle

Example: Best 12 MHz fast cycle performance can be achieved using the basic frequency of 16 MHz (CFS = 1, FFS = 1) and the appropriate count interval bits (CI1 = 1, CI0 = 1) to reduce the frequency.

$$\text{clock period} \times \text{refresh count interval} = \text{refresh period}$$

$$\text{i.e. } 83.3 \text{ ns} \times 164 = 13.6 \mu\text{s}$$

Example: 10 MHz slow cycle

$$\text{CFS} = 0, \text{FFS} = 1, \text{CI1} = 0, \text{CI0} = 0$$

$$\text{i.e. } 100 \text{ ns} \times 118 = 11.8 \mu\text{s}$$

Processor Timing

In order to run without wait states, $\overline{\text{AACK}}$ must be used and connected to the $\overline{\text{SRDY}}$ input of the appropriate bus controller. $\overline{\text{AACK}}$ is issued relative to a point within the RAM cycle and has no fixed relationship to the processors's request. The timing is such, however, that the processor will run without wait states, barring refresh cycles. In slow cycle, fast RAM configurations (8086, 80186), $\overline{\text{AACK}}$ is issued on the same clock cycle that issues $\overline{\text{RAS}}$.

Port Enable ($\overline{\text{PE}}$) set-up time requirements depend on whether the 82C08 is configured for synchronous

or asynchronous, fast or slow cycle operation. In a synchronous fast cycle configuration, \overline{PE} is required to be set-up to the same clock edge as the commands. If \overline{PE} is true (low), a RAM cycle is started; if not, the cycle is not started until the RD or WR line goes inactive and active again.

In asynchronous operation, \overline{PE} is required to be set-up to the same clock edge as the internally synchronized status or commands. Externally, this allows the internal synchronization delay to be added to the status (or command) -to- \overline{PE} delay time, thus allowing for more external decode time than is available in synchronous operation.

The minimum synchronization delay is the additional amount that \overline{PE} must be held valid. If \overline{PE} is not held valid for the maximum synchronization delay time, it is possible that \overline{PE} will go invalid prior to the status or command being synchronized. In such a case the 82C08 may not start a memory cycle. If a memory cycle intended for the 82C08 is not started, then no acknowledge (AACK or XACK) is issued and the processor locks up in endless wait states.

Memory Acknowledge (\overline{AACK} , \overline{XACK})

Two types of memory acknowledge signals are supplied by the 82C08. They are the Advanced Acknowledge strobe (\overline{AACK}) and the Transfer Acknowledge strobe (\overline{XACK}). The S programming bit optimizes \overline{AACK} for synchronous operation ("early" \overline{AACK}) or asynchronous operation ("late" \overline{AACK}). Both the early and late \overline{AACK} strobes are two clocks long for CFS = 0 and three clocks long for CFS = 1.

The \overline{XACK} strobe is asserted when data is valid (for reads) or when data may be removed (for writes) and meets the MULTIBUS requirements. \overline{XACK} is removed asynchronously by the command going inactive.

Since in an asynchronous operation the 82C08 removes read data before late \overline{AACK} or \overline{XACK} is recognized by the CPU, the user must provide for data latching in the system until the CPU reads the data. In synchronous operation data latching is unnecessary, since the 82C08 will not remove data until the CPU has read it.

If the X programming bit is high, the strobe is configured as \overline{XACK} , while if the bit is low, the strobe is configured as \overline{AACK} .

Data will always be valid a fixed time after the occurrence of the advanced acknowledge. Thus, the advanced acknowledge may also serve as a RAM cycle timing indicator.

General System Considerations

1. The $\overline{RAS0}$, 1, $\overline{CAS0}$, 1, and A00-8 output buffers are designed to directly drive the heavy capacitive loads of the dynamic RAM arrays. To keep the RAM driver outputs from ringing excessively in the system environment it is necessary to match the output impedance with the RAM array by using series resistors. Each application may have different impedance characteristics and may require different series resistance values. The series resistance values should be determined for each application.
2. Although the 82C08 has programmable options, in practice there are only a few choices the designer must make. For iAPX 86/186 systems (CFS = 0) the C2 default mode (pin 33 tied low) is the best choice. This permits zero wait states at 8 and 10 MHz with 150 ns DRAMs. The only consideration is the refresh rate, which must be programmed if the CPU is run at less than 8 MHz.
For iAPX 286 systems (CFS = 1) the designer must choose between configuration C0 (RFS = 0) and C1 (RFS = 1, FFS = 0). C0 permits zero wait state, 8 MHz iAPX 286 operation with 120 ns DRAMs. However, for consecutive reads, this performance depends on interleaving between two banks. The C1 configuration trades off 1 wait state performance for the ability to use 150 ns DRAMs. 150 ns DRAMs can be supported by the C0 configuration using 7 MHz iAPX 286.
3. For non-Intel microprocessors, the asynchronous command mode would be the best choice, since Intel status lines are not available. To minimize the synchronization delay, the 82C08 should use a 16 MHz clock. The preferred timing configuration is C0.

Table 7. Memory Acknowledge Summary

	Synchronous	Asynchronous	XACK
Fast Cycle	AACK Optimized for Local 80286 (early)	AACK Optimized for Remote 80286 (late)	Multibus Compatible
Slow Cycle	AACK Optimized for Local 8086/186 (early)	AACK Optimized for Remote 8086/186 (late)	Multibus Compatible

POWER DOWN

During Power Down (PD) mode, the 82C08 will perform refresh cycles to preserve the memory content. Two pins are dedicated to this feature, PDD (Power Down Detect) and PDCLK (Power Down Clock). PDD is used to inform the 82C08 of a system power failure, and will remain active as long as the power is down. It is the system's responsibility to detect power failure and to supply this signal. PDCLK is used to supply the clock during power down for the 82C08 refresh circuits. It is the system's responsibility to supply this clock.

Power Supplies

Power down is achieved by eliminating the clock from all the 82C08 circuits that are not participating in the refresh generation. The 82C08 has two power pins (V_{CC} 's), one supplies power to the output buffers and the other, to 82C08 logic. All the active circuits during power down are connected to the logic V_{CC} , including the active output buffers. Therefore, it is the user's choice to connect only the logic V_{CC} pin to the back-up power supply, or to connect both pins to it. It is recommended, however, to connect both pins to the same power supply in order to simplify and to shorten the power up time.

Extended Refresh at Power Down (PD)

To reduce power dissipation during PD, 82C08 will support the extended refresh cycle of the Intel 51CXXL (e.g. 51C64L). In this mode, the refresh period can be extended up to 64 milliseconds versus 4 milliseconds in non-extended cycles. This is achieved by slowing down the PDCLK frequency.

The user should take into consideration that when supporting extended refresh during PD, the dynamic RAM must be refreshed completely within 4 milliseconds, without active cycles, both before going into and after coming out of extended refresh. The 82C08 has the option of performing burst refresh of all the memory whenever the user cannot guarantee the 4 milliseconds idle interval. This is achieved by performing 3 consecutive burst refresh cycles, activated internally by the 82C08.

The option of refreshing all the memory is enabled in failsafe mode configuration (RFRQ input high at reset). When 82C08 detects power down, (high level at PDD) it examines the RFRQ input. High level at the RFRQ input will cause 3 PD burst refresh cycles to be performed. The user should supply the power and the system clock during the time interval of the 3 PD burst cycles, e.g. 4700 (fast cycle) or 3100 (slow cycle) clock cycles after activating PDD. Low level at RFRQ input enables the 82C08 to enter

power down immediately without executing any bursts.

Power Down Procedure

The 82C08 will preserve the memory content during the entire period of the system operation. Upon detection of power down, the 82C08 will save internally its configuration status and the refresh address counter content, execute 3 burst refresh cycles. (If it is programmed to failsafe mode and the RFRQ input level is high), it will switch the internal clock from the system clock (CLK) to the power down clock (PDCLK) and will continue the refresh to the next address location. (See Figure 11.)

When power is up again (PDD input deactivated), the 82C08 will issue internal reset which will not re-program the device and will not clear the refresh address counter, and therefore, refresh will continue to the next address location. After the internal reset, 82C08 performs 3 PD burst refresh cycles which refresh the whole memory, as at entering extended PD. This is done to give the 82C08 enough time to wake up. Notice, at the time interval of 4700 (fast cycle) or 3100 (slow cycle) clocks after power recovering no memory access will be performed.

82C08 Outputs on Power Down

Four of the 82C08 outputs are not activated during power down, \overline{AACK} , $\overline{CAS0-1}$ and \overline{WE} . All these outputs will be forced to a non-active state, \overline{AACK} and $\overline{CAS0-1}$ will be forced high and \overline{WE} will be forced low (External NAND buffer is used to drive the \overline{WE} DRAM inputs, hence a high level on the DRAM inputs). The other 82C08 outputs, $\overline{AO0-9}$ and $\overline{RAS0-1}$, will switch to perform the memory refresh in a "RAS-ONLY REFRESH CYCLE." The \overline{RAS} outputs internal pull-ups assure high levels on these outputs, as close as possible to V_{CC} , for low DRAM power. The size of the output buffers, in power down, is smaller than the normal size, and therefore, the speed of these buffers is slower. It is done in order to reduce the speed of charging and discharging the outputs and hence reduce spikes on the power lines. It is required especially in power down, since there is only one power supply pin active which drives the output buffers as well as the internal logic.

All the device inputs, beside PDD, PDCLK, and RESET will be ignored during power down.

During power down burst refresh the 82C08 performs up to 256 refreshes. Whereas during standard burst refresh the 82C08 performs up to 128 refreshes. The power down burst refresh feature allows the 82C08 to support extended refreshes of some DRAMs, configured as 512 rows.

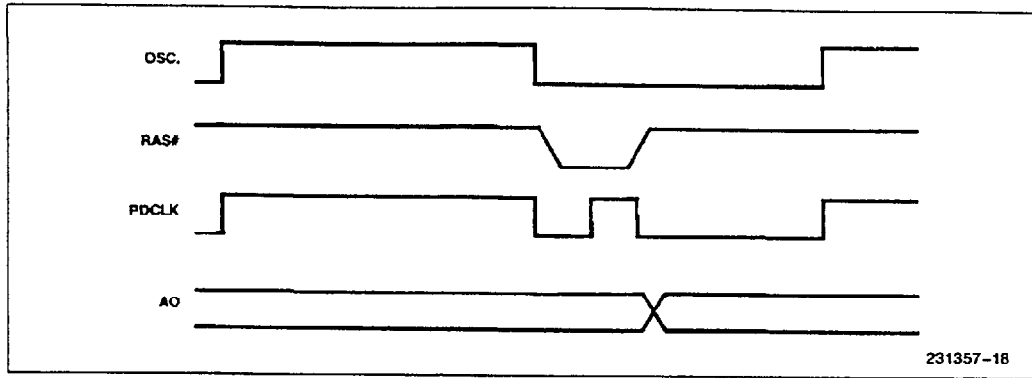

Figure 8

Power Down Detect

As previously mentioned, the PDD input will be supplied by the system to inform the 82C08 of a power failure. It can be asynchronous since the 82C08 synchronizes it internally. The PDD input will be sampled by the 82C08 before the beginning of every memory cycle but only after the termination of programming and initialization period. The user should guarantee V_{CC} and CLK stable during the programming and initialization period (300 clocks after RESET). If the whole memory refresh is required (for extended refresh) then V_{CC} and system clock should be available 4700 (fast cycle) or 3100 (slow cycle) clocks after activating PDD. If it isn't required then 82C08 should wait for present memory cycle completion and synchronization time which will take about 25 system clock cycles.

With PDD going inactive, the 82C08 synchronizes the clock back to the CLK clock, issuing internal reset and will perform 3 PD burst refresh cycles.

NOTE:

The power supplies and the CLK should go up before the PDD is deactivated. All CPU requests will be ignored when PDD is active.

Refresh during Power Down

The 82C08 has two clock pins, CLK is the system clock and PDCLK is the power down clock. PDCLK should be an independent clock which has its own crystal oscillator. When entering power down, the 82C08 will disable the system clock internally and will run with the PDCLK. The system clock will be enabled and the PDCLK will be disabled when power is up. The CLK and PDCLK will be switched internally for the refresh circuits.

During power down, 'RAS-ONLY REFRESH' will be performed by the 82C08. The time interval between refreshes is 5 PDCLKs and this is fixed for all applications. However, the 82C08 can support the extended refresh (up to 64 ms) by slowing down the PDCLK frequency.

During the power down refresh cycle, \overline{RAS} will be activated for one PDCLK cycle only. In extended refresh, the PDCLK frequency will be below 50 kHz and this will cause a long duration of the RAS signal which will increase the DRAM's current rapidly. To minimize the \overline{RAS} low pulse, the two RC networks shown in Figure 9 are designed to insert one very fast (1 μ s) cycle whenever \overline{RAS} is low (see Figure 8). The time constant of RC1 and RC2 should be centered around 300 ns and 100 ns respectively.

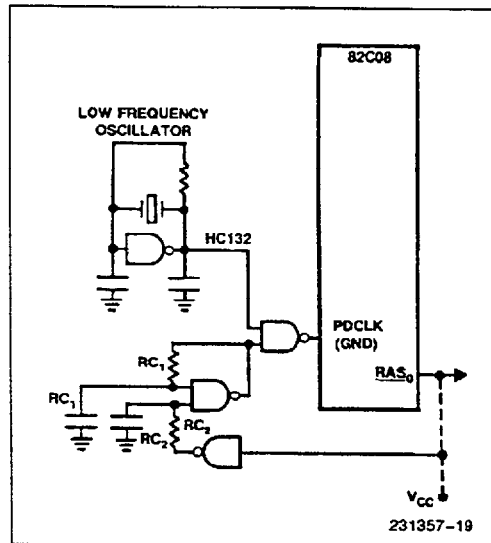

Figure 9. Low Frequency Oscillator

Power Down Synchronization

The 82C08 main clock (MCLK) is generated internally, from the system clock (CLK) and the power down clock (PDCLK) (see Figure 10), and is driving the circuits that are active at all times, i.e.: circuits that are active both in power down mode and in normal operation. The system clock (CLK) is driving the circuits that are active in normal operation only, and the PDCLK is driving the circuits that are active in power down only. The operation of the three clocks is as follows:

When entering power down mode, and the whole memory refresh is required, the CLK minimum active

time after PDD is activated is 4700 (fast cycle) or 3100 (slow cycle) clocks.

When it isn't required, PDCLK should be active, and CLK should remain active for at least 20 clock cycles + synchronization time. The synchronization time is the ratio of PDCLK and CLK + 1. Therefore, the CLK minimum active time after PD is activated:

$$20 + \lceil \text{CLK}(\text{MHz}) / \text{PDCLK}(\text{MHz}) + 1 \rceil \text{ clock cycles}$$

When the power is up again, PDCLK should remain active at least 4 clock cycles after PD is going inactive, to assure completion of refresh cycle and internal synchronization time.

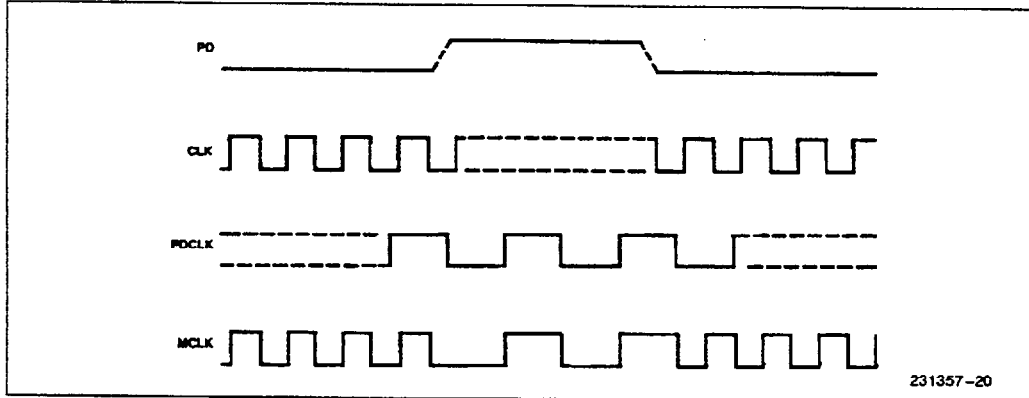

Figure 10

POWER DOWN FLOW

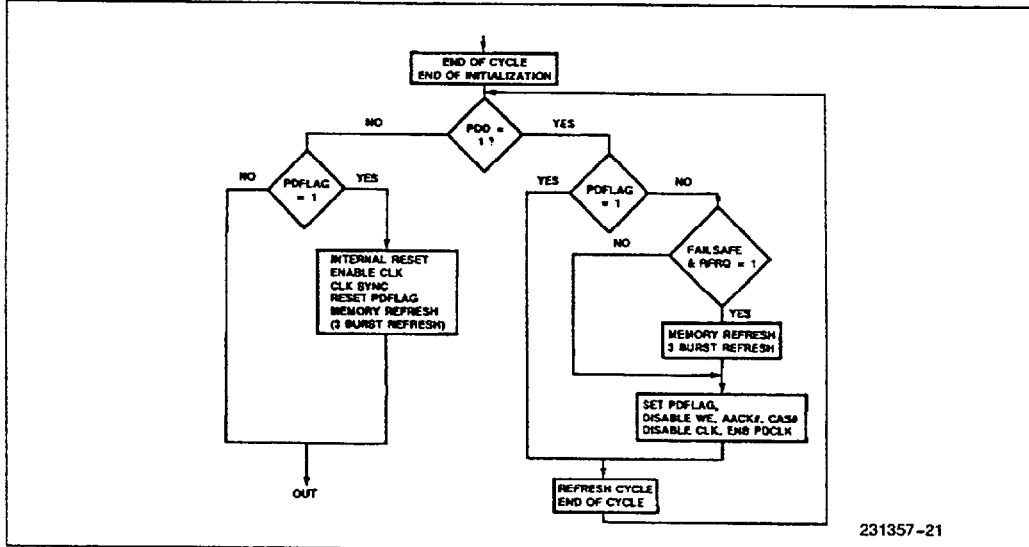

Figure 11

Differences Between 8208 and 82C08

The differences between the HMOS 8208 and the CHMOS 82C08 represent forward compatible enhancements. The 82C08 can be plugged into an 8208 socket without changes.

LOGICAL DIFFERENCES

- 82C08 has one new feature:
Power Down (PD)
- 82C08 supports CMOS DRAMs with T_{RAC} 100, 150
- Address Mapping:

Outputs	9 Most Significant Bits	9 Least Significant Bits
8208	column address	row address
82C08	row address	column address

- Slow cycle shortening:
 - The write cycle is two clocks shorter so consecutive writes will be executed without wait states.
 - The WE output is two clocks shorter. Therefore, an external latch on the WE output is not necessary.
 - CAS output is shorter by one clock on the read cycle. This reduces one level of buffers for address/data bus needed in 8208 designs. Read access margins are improved to support non-Intel spec. RAMs.
 - The address outputs switch from row to column address one clock cycle later in the 82C08 as compared to 8208.
- Fast cycle shortening:
 - The write cycle in C0 configuration is shortened by one clock.
 - For both C0 and C1 synchronous configuration, the CAS signal is shorter by one clock and the activation of RAS is tied to the $\Phi 2$ cycle of the 80286. This prevents contention on the data bus.
- Supports Static Column or Ripplemode DRAMs.

ELECTRICAL DIFFERENCES

- AC parameters:
 - CAS delay: In C2 synchronous read cycle, the CAS is deactivated by some delay from clock falling edge (TCLCSH timing) as in the following diagram:
In C2 write cycles the CAS activation is triggered by the clock falling edge with a delay of 35 ns from the clock. For 8208 the delay is $TP/1.8 + 53$.

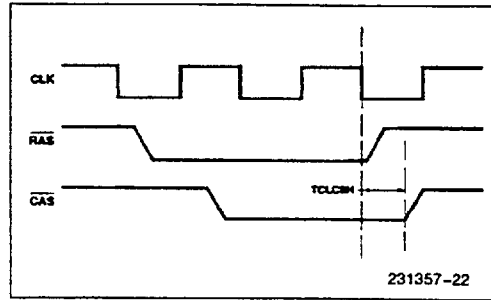

- 82C08 has an additional timing parameter TARH column address to RAS \uparrow hold time.
- DC parameters: The difference is in the current consumption.

	8208	82C08
I_{CC}	300 mA	30 mA (typical) [10 + 2f] mA (max)
IPD	—	1 mA (max)
I_{SB}	—	2 mA (max)

Configuration Charts

The 82C08 operates in three basic configurations—C0, C1, C2—depending upon the programming of CFS (PD0), RFS (PD2), and FFS (PD7). Table 8 shows these configurations. These modes determine the clock edges for the 82C08's programmable signals, as shown in Table 9. Finally, Table 10 gives the programmable AC parameters of the 82C08 as a function of configuration. The non-programmable parameters are listed under AC Characteristics.

Using the Timing Charts

The notation used to indicate which clock edge triggers an output transition is " $n \uparrow$ " or " $n \downarrow$ ", where " n " is the number of clock periods that have passed since clock 0, the reference clock, and " \uparrow " refers to rising edge and " \downarrow " to falling edge. A clock period is defined as the interval from a clock falling edge to the following falling edge. Clock edges are defined as shown below.

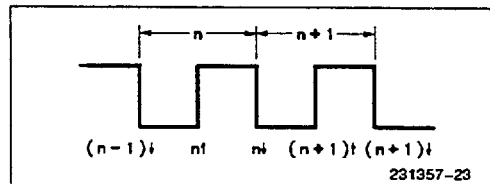

The clock edges which trigger transitions on each 82C08 output are tabulated in Table 9. "H" refers to the high-going transition, and "L" to low-going transition.

Clock 0 is defined as the clock in which the 82C08 begins a memory cycle, either as a result of a port request which has just arrived, or of a port request which was stored previously but could not be serv-

iced at the time of its arrival because the 82C08 was performing another memory cycle. Clock 0 is identified externally by the leading edge of RAS, which is always triggered on 0 ↓.

Table 8. 82C08 Configurations

Timing Conf.	CFS(PD0)	RFS(PD2)	FFS(PD7)	Wait States*
C ₀	iAPX286(1)	FAST RAM(1)	20 MHz(1)	0
C ₀	iAPX286(1)	FAST RAM(1)	16 MHz(1)	0
C ₁	iAPX286(1)	SLOW RAM(0)	16 MHz(1)	1
C ₀	iAPX286(1)	FAST RAM(1)	10 MHz (0)	0
C ₀	iAPX286(1)	SLOW RAM(0)	10 MHz (0)	0
C ₂	iAPX186(0)	DON'T CARE	DON'T CARE	0

* Using EAACK (synchronous mode)

Table 9a. Timing Chart — Synchronous Mode

Cn	Cycle	RAS		ADDRESS		CAS		WE		EAACK	
		L	H	Col	Row*	L	H	H	L	L	H
0	RD,RF	0↓	3↓	0↓	3↓	1↓	3↓			1↓	4↓
	WR	0↓	4↓	0↓	3↓	2↓	4↓	1↓	4↓	1↓	4↓
1	RD,RF	0↓	4↓	0↓	4↓	1↓	5↓			2↓	5↓
	WR	0↓	5↓	0↓	4↓	2↓	5↓	1↓	5↓	2↓	5↓
2	RD,RF	0↓	2↓	0↓	3↓	0↓	2↓			0↓	2↓
	WR	0↓	2↓	0↓	3↓	1↓	3↓	0↓	2↓	0↓	2↓

Table 9b. Timing Chart — Asynchronous Mode

Cn	Cycle	RAS		ADDRESS		CAS		WE		LAACK		XAACK	
		L	H	Col	Row*	L	H	H	L	L	H	L	H
0	RD,RF	0↓	3↓	0↓	3↓	1↓	4↓			2↓	5↓	3↓	RD
	WR	0↓	4↓	0↓	3↓	2↓	4↓	1↓	4↓	1↓	4↓	3↓	WR
1	RD,RF	0↓	4↓	0↓	4↓	1↓	6↓			2↓	5↓	4↓	RD
	WR	0↓	5↓	0↓	4↓	2↓	5↓	1↓	5↓	1↓	4↓	3↓	WR
2	RD,RF	0↓	2↓	0↓	3↓	0↓	3↓			1↓	3↓	2↓	RD
	WR	0↓	2↓	0↓	3↓	1↓	3↓	0↓	2↓	1↑	3↑	2↓	WR

The only difference between the two tables is the trailing edge of CAS for all read cycle configurations. In asynchronous mode, CAS trailing edge is one clock later than in synchronous mode.

NOTES FOR INTERPRETING THE TIMING CHART:

1. COLUMN ADDRESS is the time column address becomes valid.
2. The CAS, EAACK, LAACK and XACK outputs are not issued during refresh.
3. XACK—high is reset asynchronously by command going inactive and not by a clock edge.
4. EAACK is used in synchronous mode, LAACK and XACK in asynchronous mode.
5. ADDRESS-Row is the clock edge where the 82C08 A0 switches from current column address to the next row address.
6. If a cycle is inhibited by PCTL = 1 (Multibus I/F mode) then CAS is not activated during write cycle and XACK is not activated in either read or write cycles.

*Column addresses switch to row addresses for next memory cycle. The row address buffer is transparent following this clock edge. 'TRAH' specification is guaranteed as per data sheet.

82C08—DRAM Interface Parameter Equations

Several DRAM parameters, but not all, are a direct function of 82C08 timings, and the equations for these parameters are given in the following tables. The following is a list of those DRAM parameters which have NOT been included in the following tables, with an explanation for their exclusion.

WRITE CYCLE

tDS: system-dependent parameter.
tDH: system-dependent parameter.
tDHR: system-dependent parameter.

READ, WRITE REFRESH CYCLES

tRAC: response parameter.
tCAC: response parameter.
tREF: See "Refresh Period Options".
tCRP: must be met only if CAS-only cycles, which do not occur with 82C08, exist.
tRAH: See "A.C. Characteristics"
tRCD: See "A.C. Characteristics"
tASC: See "A.C. Characteristics"
tASR: See "A.C. Characteristics"
tOFF: response parameter.

Table 10. Programmable Timings

Read and Refresh Cycles

Parameter	C2-Slow Cycle	C0-Fast Cycle	C1-Fast Cycle	Notes
tRP	2TCLCL-T27	3TCLCL-T27	3TCLCL-T27	1
tCPN	1.5TCLCL-T34	3TCLCL-T34	2TCLCL-T34	1,6
tCPN	2.5TCLCL-T34	4TCLCL-T34	3TCLCL-T34	1,4
tRSH	2TCLCL-T32	2TCLCL-T32	3TCLCL-T32	1
tCSH	3TCLCL-T25	4TCLCL-T25	6TCLCL-T25	1,5
tCSH	2TCLCL + T34(min)-T25	3TCLCL-T25	5TCLCL-T25	1,4
tCAH	3TCLCL-T32	2TCLCL-T32	3TCLCL-T32	1
tAR	3TCLCL-T25	3TCLCL-T25	4TCLCL-T25	1
tT	3/30	3/30	3/30	2
tRC	4TCLCL	6TCLCL	7TCLCL	1
tRAS	2TCLCL-T25	3TCLCL-T25	4TCLCL-T25	1
tCAS	3TCLCL-T32	3TCLCL-T32	5TCLCL-T32	1,5
tCAS	2TCLCL + T34(min)-T32	2TCLCL-T25	4TCLCL-T32	1,4
tRCS	TCLCL + T32(min)-T35 + TBUF	TCLCL-T35 + TBUF	2TCLCL-T35 + TBUF	1
tRCH	TCLCL + T36(min)-T34 + TBUF	TCLCL-T34 + TBUF	2TCLCL-T34 + TBUF	1

Write Cycles

Parameter	C2-Slow Cycle	C0-Fast Cycle	C1-Fast Cycle	Notes
tRP	2TCLCL-T27	3TCLCL-T27	3TCLCL-T27	1
tCPN	2TCLCL-T34	4TCLCL-T34	4TCLCL-T34	1
tRSH	TCLCL-T32	2TCLCL-T32	3TCLCL-T32	1
tCSH	3TCLCL-T25	4TCLCL-T25	5TCLCL-T25	1
tCAH	2TCLCL-T32	TCLCL-T32	2TCLCL-T32	1
tAR	3TCLCL-T25	3TCLCL-T25	4TCLCL-T25	1
tT	3/30	3/30	3/30	2
tRC	4TCLCL	7TCLCL	8TCLCL	1
tRAS	2TCLCL-T25	4TCLCL-T25	5TCLCL-T25	1
tCAS	2TCLCL-T32 + TBUF	2TCLCL-T32	3TCLCL-T32	1
tWCH	TCLCL-T32 + TBUF	2TCLCL-T32 + TBUF	3TCLCL-T32 + TBUF	1,3
tWCR	2TCLCL-T25 + TBUF	4TCLCL-T25 + TBUF	5TCLCL-T25 + TBUF	1,3
tWP	2TCLCL-T36-TBUF	3TCLCL-T36-TBUF	4TCLCL-T36-TBUF	1
tRWL	2TCLCL-T36-TBUF	3TCLCL-T36-TBUF	4TCLCL-T36-TBUF	1
tCWL	3TCLCL-T36-TBUF	3TCLCL-T36-TBUF	4TCLCL-T36-TBUF	1
tWCS	TCLCL + T36-T31-TBUF	TCLCL - T36-TBUF	TCLCL - T36-TBUF	1

NOTES:

1. Minimum.
2. Value on right is maximum; value on left is minimum.
3. Applies to the eight warm-up cycles during initialization.
4. For synchronous mode only.
5. For asynchronous mode only.

ABSOLUTE MAXIMUM RATINGS*

Ambient Temperature Under Bias	-0°C to +70°C
Storage Temperature	-65°C to +150°C
Voltage On Any Pin With Respect to Ground	-0.5V to +7V
Power Dissipation	0.5W

NOTICE: This is a production data sheet. The specifications are subject to change without notice.

*WARNING: Stressing the device beyond the "Absolute Maximum Ratings" may cause permanent damage. These are stress ratings only. Operation beyond the "Operating Conditions" is not recommended and extended exposure beyond the "Operating Conditions" may affect device reliability.

D.C. CHARACTERISTICS $T_A = 0^\circ\text{C to } 70^\circ\text{C}; V_{CC} = 5.0\text{V} \pm 10\%; V_{SS} = \text{GND}$

Symbol	Parameter	Min	Max	Units	Comments
V_{IL}	Input Low Voltage	-0.5	+0.8	V	
V_{IH}	Input High Voltage	2.0	$V_{CC} + 0.5$	V	
V_{OL}	Output Low Voltage		0.45	V	(Note 1)
V_{OH}	Output High Voltage	2.6		V	(Note 1)
I_{CC}	Supply Current		$10 + 2f$	mA	(Note 3)
I_{LI}	Input Leakage Current		± 10	μA	$0\text{V} \leq V_{IN} \leq V_{CC}$
V_{CL}	Clock Input Low Voltage	-0.5	+0.6	V	
V_{CH}	Clock Input High Voltage	3.8	$V_{CC} + 0.5$	V	
C_{IN}	Input Capacitance		20	pF	$f_c = 1 \text{ MHz}^{(6)}$
V_{OHPD}	RAS Output High Power Down	$V_{CC} - 0.5$		V	(Note 2)
I_{PD}	Power Down Supply Current	—	5.0	mA	(Note 5)
I_{SB}	Standby Current	—	2.0	mA	(Note 4)

NOTE:

- $I_{OL} = 5 \text{ mA}$ and $I_{OH} = -0.32 \text{ mA}$ WE: $I_{OL} = 8 \text{ mA}$
- RAS Output voltage during power down.
- Typical value. Where f is freq. in MHz.
- for CMOS: $V_{IL} \text{ max} = 0.5\text{V}; V_{IH} \text{ min} = (V_{CC} - 0.5\text{V})$
for TTL: I_{CC} will be higher by 30 mA

- Measured at $V_{IL} = 0\text{V}$ and $V_{IH} = V_{CC}$ with no loads connected.
- $I_{PD} = 1 \text{ mA}$ at 32 KHz with no loads connected.
- Sampled, not 100% tested. $T_A = 25^\circ\text{C}$.

A.C. Testing Load Circuit

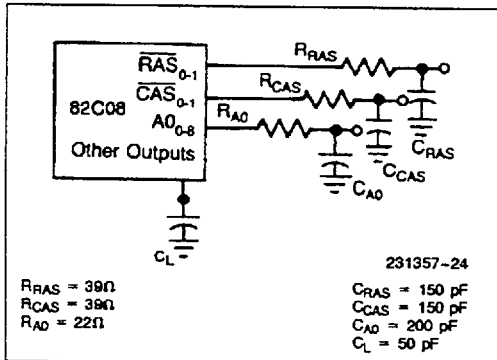

A.C. Testing Input, Output Waveform

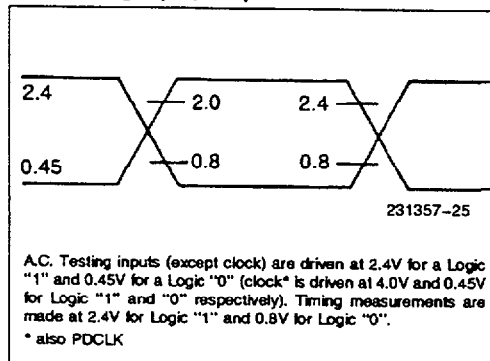

A.C. CHARACTERISTICS ($T_A = 0^\circ\text{C}$ to 70°C ; $V_{CC} = +5\text{V} \pm 10\%$, $V_{SS} = 0\text{V}$)

Measurements made with respect to RAS_{0-1} , CAS_{0-1} , AO_{0-8} , are at +2.4V and 0.8V CLK at 3V, 1V. All other pins are measured at 2.0V and 0.8V. All times are ns unless otherwise indicated. Testing done with specified test load.

Ref	Symbol	Parameter	Min	Max	Units	Notes
CLOCK AND PROGRAMMING						
	tF	Clock Fall Time		12	ns	3
	tR	Clock Rise Time		12	ns	3
1	TCLCL	Clock Period 82C08-20 82C08-16 82C08-10 82C08-8	50 62.5 100 125	250 250 500 500	ns ns ns ns	1 1 2 2
2	TCL	Clock Low Time 82C08-20 82C08-16 82C08-10 82C08-8	12 15 44 TCLCL/2-12	230 230	ns ns ns ns	1 1 2 2
3	TCH	Clock High Time 82C08-20 82C08-16 82C08-10 82C08-8	16 20 44 TCLCL/3+2	230 230	ns ns ns ns	1 1 2 2
4	TRTVCL	Reset to CLK \downarrow Setup	40		ns	4
5	TRTH	Reset Pulse Width	4TCLCL		ns	
6	TPGVRTL	PCTL, PDI, RFRQ to RESET \downarrow Setup	125		ns	5
7	TRTLPGX	PCTL, RFRQ to RESET \downarrow Hold	10		ns	
8	TCLPC	PCLK from CLK \downarrow Delay		45	ns	
9	TPDI \downarrow CL	PDI to CLK \downarrow Setup	60		ns	
10	TCLPDX	PDI to CLK \downarrow Hold	40		ns	6
SYNCHRONOUS μP PORT INTERFACE						
11	TPEVCL	PE to CLK \downarrow Setup	30			2
12	TKVCL	RD, WR, PE, PCTL to CLK \downarrow Setup	20		ns	1
13	TCLKX	RD, WR, PE, PCTL to CLK \downarrow Hold	0		ns	
14	TKVCH	RD, WR, PCTL to CLK \uparrow Setup	20		ns	2

A.C. CHARACTERISTICS (Continued)

Ref	Symbol	Parameter	Min	Max	Units	Notes
ASYNCHRONOUS μP PORT INTERFACE						
15	TRWVCL	\overline{RD} , \overline{WR} to CLK \downarrow Setup	20		ns	8.9
16	TRWL	\overline{RD} , \overline{WR} Pulse Width	2TCLCL + 30		ns	
17	TRWLPEV	\overline{PE} from \overline{RD} , \overline{WR} \downarrow Delay CFS = 1 CFS = 0		TCLCL-20	ns	1
				TCLCL-30	ns	2
18	TRWLPEX	\overline{PE} to \overline{RD} , \overline{WR} \downarrow Hold	2TCLCL + 30		ns	
19	TRWLPTV	PCTL from \overline{RD} , \overline{WR} \downarrow Delay		TCLCL-30	ns	2
20	TRWLPTX	PCTL to \overline{RD} , \overline{WR} \downarrow Hold	2TCLCL + 30		ns	2
21	TRWLPTV	PCTL from \overline{RD} , \overline{WR} \downarrow Delay		2TCLCL-20	ns	1
22	TRWLPTX	PCTL to \overline{RD} , \overline{WR} \downarrow Hold	3TCLCL + 30		ns	1
RAM INTERFACE						
23	TAVCL	AL, AH, BS to CLK \downarrow Set-up 82C08-20 82C08-16	35 + IASR		ns	2
			50 + IASR		ns	
			45 + IASR		ns	
24	TCLAX	AL, AH, BS to CLK \downarrow Hold	0		ns	
25	TCLRSL	RAS \downarrow from CLK \downarrow Delay		25	ns	1
				35	ns	2
				60	ns	24
26	TRCD	RAS to \overline{CAS} Delay CFS = 1 CFS = 0 CFS = 0 CFS = 0	TCLCL-25		ns	1, 14
			30		ns	23
			TCLCL/2-30		ns	2, 11, 14
			60		ns	2, 12, 14
27	TCLRSH	\overline{RAS} \uparrow from CLK \downarrow Delay		25	ns	
				60	ns	24

A.C. CHARACTERISTICS (Continued)

Ref	Symbol	Parameter	Min	Max	Units	Notes
RAM INTERFACE (Continued)						
28	TRAH	CFS = 1 CFS = 0 CFS = 0	18 TCLCL/4-10 18		ns ns	1, 13, 15 2, 11, 15 23
29	TASR	Row A0 RAS ↓ Setup				10, 16
30	TASC	Column A0 to CAS ↓ Setup CFS = 1 CFS = 0 CFS = 0	2 5 5		ns ns ns	1, 13, 17, 18 2, 13, 17, 18 23
31	TCAH	Column A0 to CAS Hold	(See DRAM Interface Tables)			
32	TCLCSL	CAS ↓ from CLK ↓ Delay CFS = 0 CFS = 0 CFS = 0 CFS = 1	TCLCL/4 + 30 50 8	TCLCL/1.8 + 56 105 35 35	ns ns ns ns	2, 26 23, 26 2, 23, 27 1
34	TCLCSH	CAS ↑ from CLK ↓ Delay	TCLCL/4	50 $\frac{TCLCL}{3.2} + 50$	ns ns	22
35	TCLWL	WE ↓ from CLK ↓ Delay		35	ns	
36	TCLWH	WE ↑ from CLK ↓ Delay CFS = 0 CFS = 1 CFS = 0	TCLCL/4 + 30 50	TCLCL/1.8 + 53 35 100	ns ns	2 1 23
37	TCLTKL	XACK ↓ from CLK ↓ Delay		35	ns	
38	TRWLTkh	XACK ↑ from RD ↑, WR ↑ Delay		50	ns	
39	TCLAKL	XACK ↓ from CLK ↓ Delay		35	ns	
40	TCLAKH	XACK ↑ from CLK ↓ Delay		50	ns	
49	TARH	Column Address to RAS ↑ Hold Time	2			1

A.C. CHARACTERISTICS (Continued)

Ref	Symbol	Parameter	Min	Max	Units	Notes
REFRESH REQUEST						
41	TRFVCL	RFRQ to CLK ↓ Setup	20		ns	
42	TCLRFX	RFRQ to CLK ↓ Hold	10		ns	
43	TFRFH	Failsafe RFRQ Pulse Width	TCLCL + 30		ns	19
44	TRFXCL	Single RFRQ Inactive to CLK ↓ Setup	20		ns	20
45	TBRFH	Burst RFRQ Pulse Width	2TCLCL + 30		ns	19
46	TPDDVCL	PDD Setup Time	20		ns	24, 25
47	TPDHRFX	RFRQ Valid after PDD Active	4TCLCL + 20			24
48	TRFVPDH	RFRQ Setup Time to PDD Active	20			24

The following RC loading is assumed:

$A0_{0-8}$ $R = 22\Omega$ $C = 200\text{ pF}$
 $RAS0_{-1}, CAS0_{-1}$ $R = 39\Omega$ $C = 150\text{ pF}$
 $AACK, WE/PCLK$ $C = 50\text{ pF}$

NOTES:

1. Specification when programmed in the Fast Cycle processor mode (iAPX 286 mode). 82C08-20, -16.
2. Specification when programmed in the Slow Cycle processor mode (iAPX 186 mode). 82C08-10, 82C08-8.
3. tR and tF are referenced from the 3.5V and 1.0V levels.
4. RESET is internally synchronized to CLK. Hence a set-up time is required only to guarantee its recognition at a particular clock edge.
5. The first programming bit (PD0) is also sampled by RESET going low.
6. TCLPDX is guaranteed if programming data is shifted using PCLK.
8. TRWVCL is not required for an asynchronous command except to guarantee its recognition at a particular clock edge.
9. Valid when programmed in either Fast or Slow Cycle mode.
10. tASR is a user specified parameter and its value should be added accordingly to TAVCL.
11. When programmed in Slow Cycle mode and $125\text{ ns} \leq \text{TCLCL} < 200\text{ ns}$.
12. When programmed in Slow Cycle mode and $200\text{ ns} \leq \text{TCLCL}$.
13. Specification for Test Load conditions.
14. $t_{RCD}(\text{actual}) = t_{RCD}(\text{specification}) + 0.06(\Delta C_{RAS}) - 0.06(\Delta C_{CAS})$ where $\Delta C = C(\text{test load}) - C(\text{actual})$ in pF. (These are first order approximations.)
15. $t_{RAH}(\text{actual}) = t_{RAH}(\text{specification}) + 0.06(\Delta C_{RAS}) - 0.022(\Delta C_{A0})$ where $\Delta C = C(\text{test load}) - C(\text{actual})$ in pF. (These are first order approximations.)
16. $t_{ASR}(\text{actual}) = t_{ASR}(\text{specification}) + 0.06(\Delta C_{A0}) - 0.025(\Delta C_{RAS})$ where $\Delta C = C(\text{test load}) - C(\text{actual})$ in pF. (These are first order approximations.)
17. $t_{ASC}(\text{actual}) = t_{ASC}(\text{specification}) + 0.06(\Delta C_{A0}) - 0.025(\Delta C_{CAS})$ where $\Delta C(\text{test load}) - C(\text{actual})$ in pF. (These are first order approximations.)
18. tASC is a function of clock frequency and thus varies with changes in frequency. A minimum value is specified.
19. TFRFH and TBRFH pertain to asynchronous operation only.
20. Single RFRQ should be supplied synchronously to avoid burst refresh.
22. CFS = 0, synchronous mode, Read cycle.
23. For 10 MHz Slow Cycle only.
24. Power down mode.
25. PDD is internally synchronized. A setup time is required only to guarantee its recognition at a particular clock edge.
26. Slow Cycle Read only.
27. Slow Cycle Write only.

WAVEFORMS

CLOCK AND PROGRAMMING TIMINGS

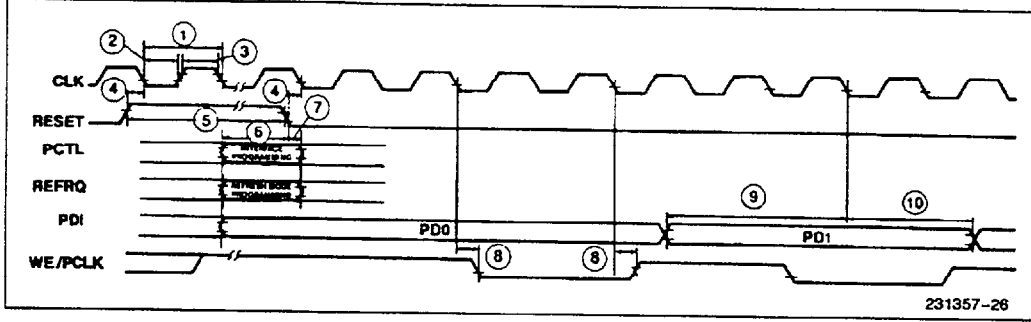

RAM WARM-UP CYCLES

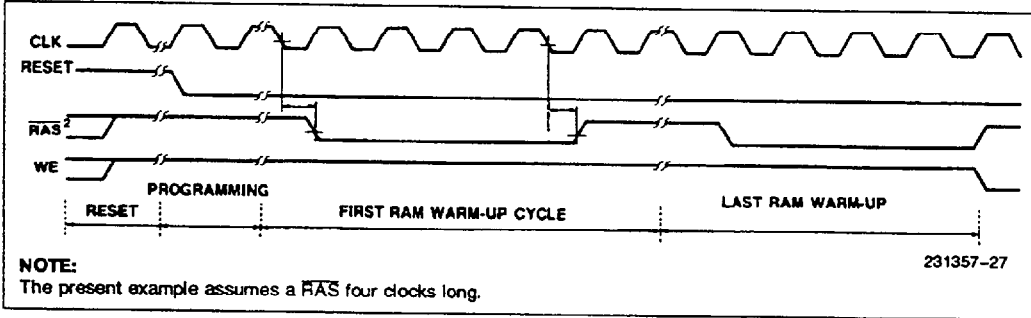

REFRESH REQUEST TIMING

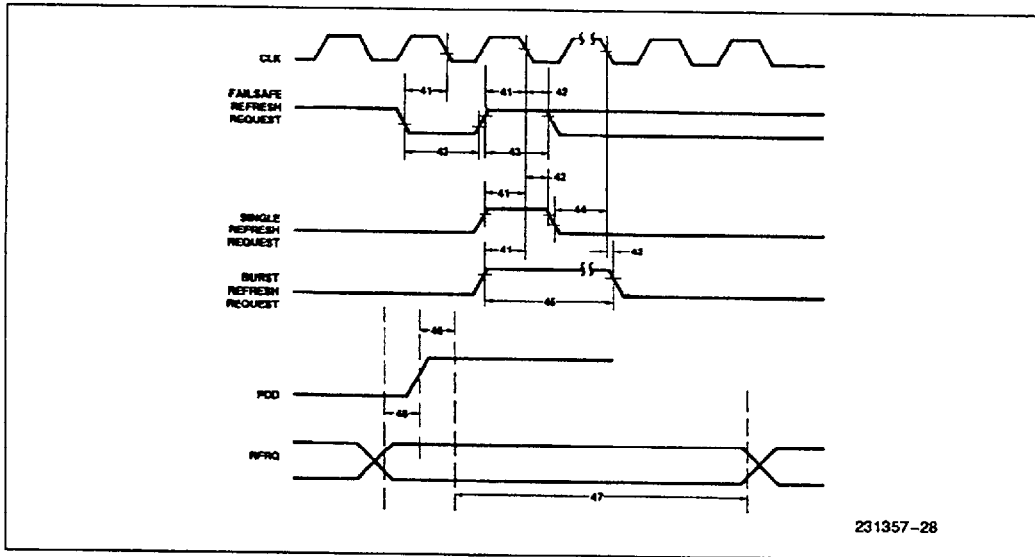

4826175 0176347 574

WAVEFORMS (Continued)

SYNCHRONOUS PORT INTERFACE

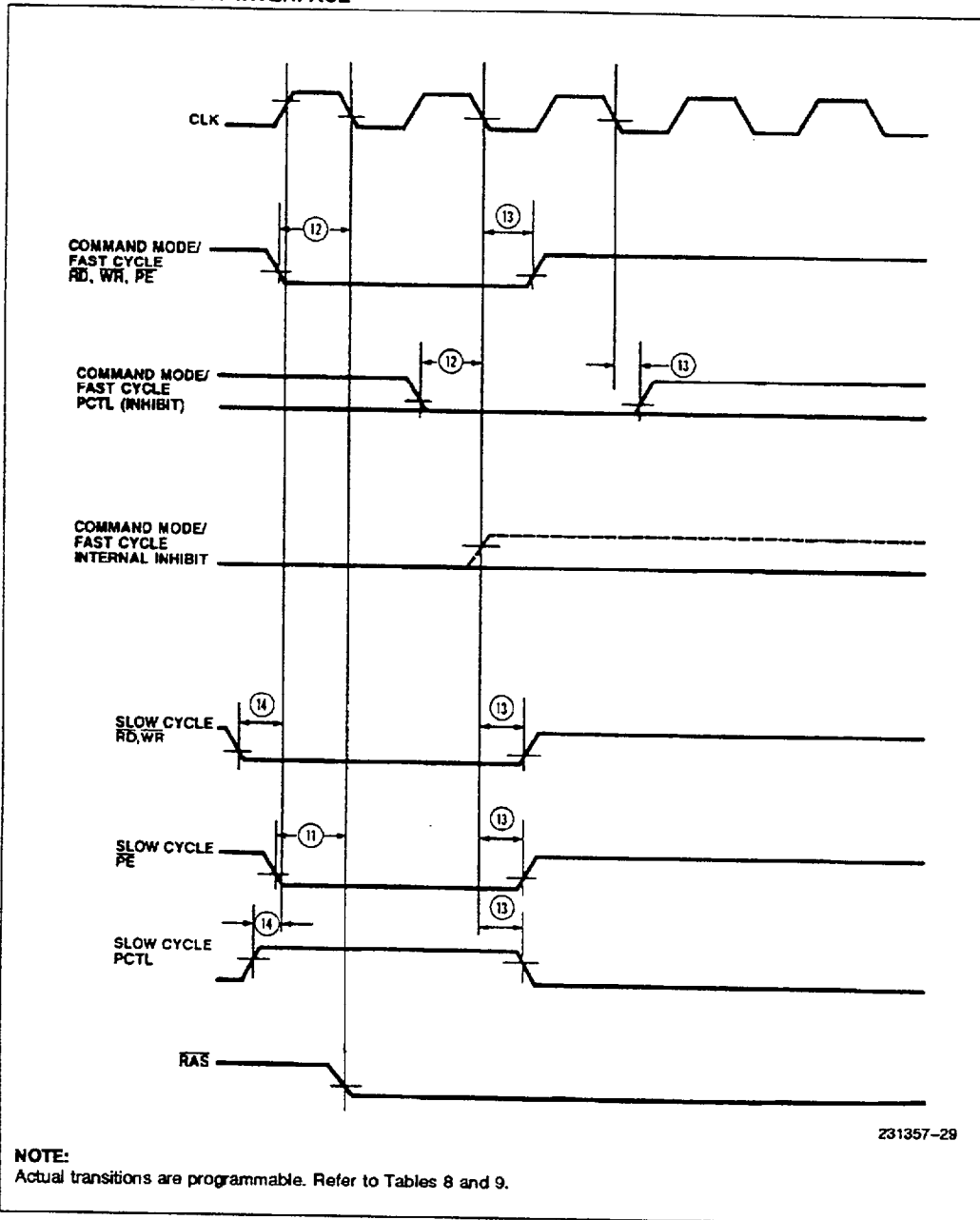

WAVEFORMS (Continued)

ASYNCHRONOUS PORT INTERFACE

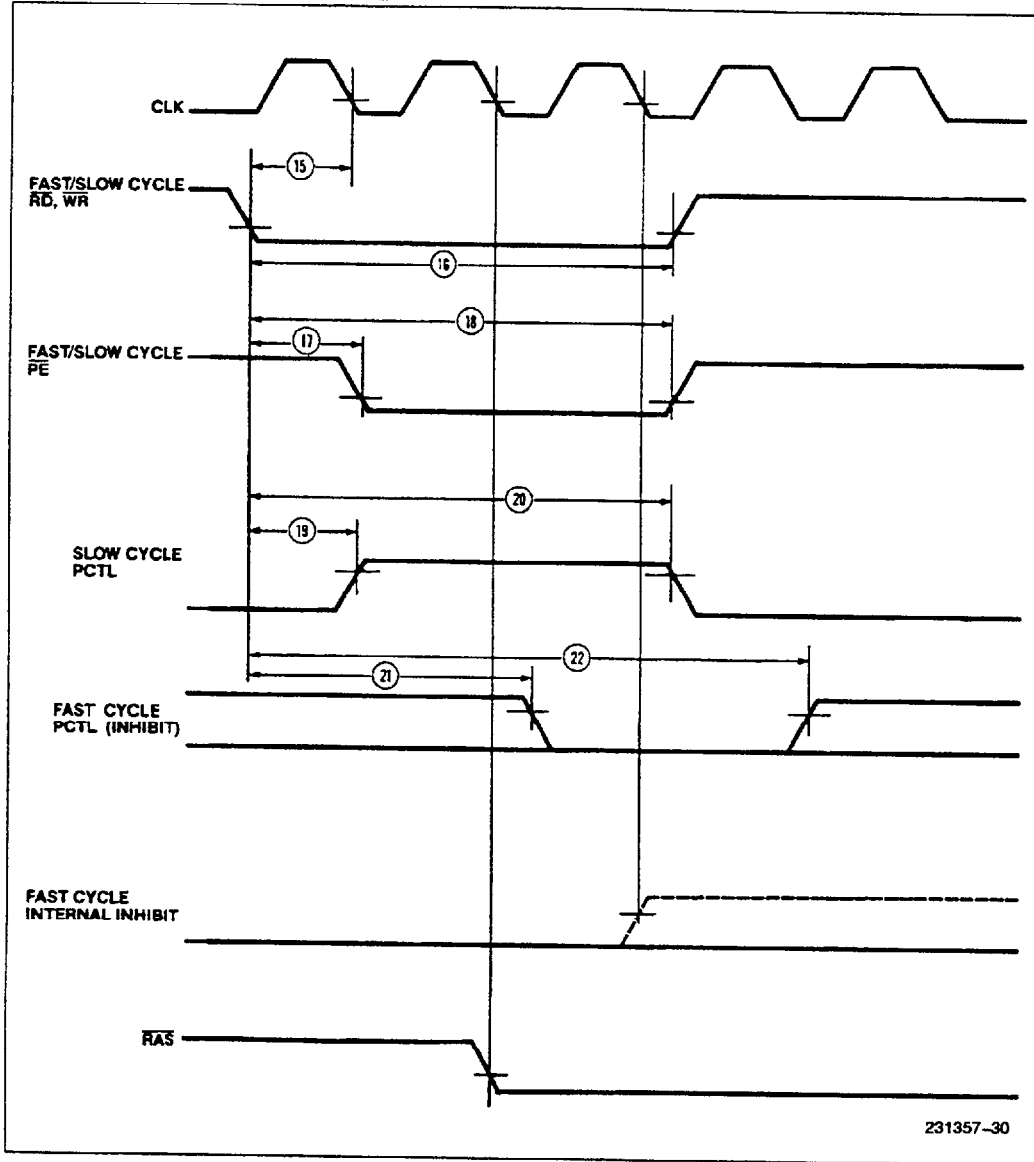

231357-30

4826175 0176349 347

WAVEFORMS (Continued)

RAM INTERFACE TIMING

