



HOSONIC ELECTRONIC CO., LTD.



SMD CRYSTAL OSCILLATOR SPECIFICATIONS

Customer	
Customer P/N	
Product	7050 OSC
Nominal Frequency	4.000000MHz
HOSONIC P/N	D7SX4E000000UE
Version	10C0
Issue Date	2020/12/15

HOSONIC		
Drawn	Checked	Approved
Drawn		
LUCY	Richard	JOHN

Approved By Customer : _____



HOSONIC ELECTRONIC CO., LTD.



Revised Record

Rev.	Rev. Date	Item	Content	Remark
1.0	2020-12-15		Initial released	

I ELECTRICAL PARAMETERS

No.	Item	Symb.	Electrical Specification				Remark	
			Min.	Typ.	Max.	Units		
1	Nominal Frequency	F0	4.000000			MHz		
2	Frequency Stability		-50		50	ppm	All condition*	
3	Operating Temperature Range	TOPR	-40		85	°C		
4	Storage Temperature	TSTG	-55		125	°C		
5	Power supply Voltage	V _{DD}	3.3±10%			V		
6	Aging Per Year	Fa	-3.0		3.0	ppm	First Year	
7	Supply current	I _{DD}			8	mA		
8	Output symmetry	Sym	45		55	%		
9	Rise time	Tr			6.0	ns	10%~90%V _{DD}	
10	Fall time	Tf			6.0	ns	90%~10%V _{DD}	
11	Output voltage	V _{OH}	90%			V _{DD}		
		V _{OL}			10%	V _{DD}		
12	Output load Hcmos Load				15	pF		
13	Start-up time				10	mS		
14	Pin 1, E/D function	pin 1=H or open.....output active at pin 3 pin 1=L.....high impedance at pin 3						
15	Package type	D7SX						

NOTE: Storage Temperature is only for the product itself,the temperature for the packing material is -4~40°C.

All condition*: Include 25°C tolerance, operating temperature range , input voltage change, aging, load change.

I STORAGE REQUIRMENT

Storage environmental conditions: -4~40°C, 70%RH max.

Maximum storage time: 24 Months from date of manufacture.

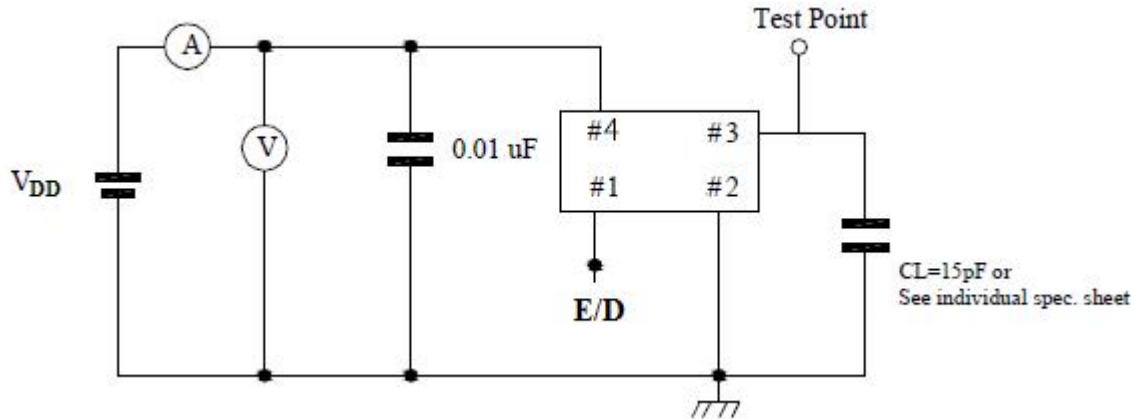
I HCMOS TEST CIRCUIT

Enable/Disable Function	
Input (pin 1)	Output (pin 3)
Open	Enable
$V_{IH} \geq 0.7V_{DD}$	Enable
$V_{IL} \leq 0.3V_{DD}$	Disable

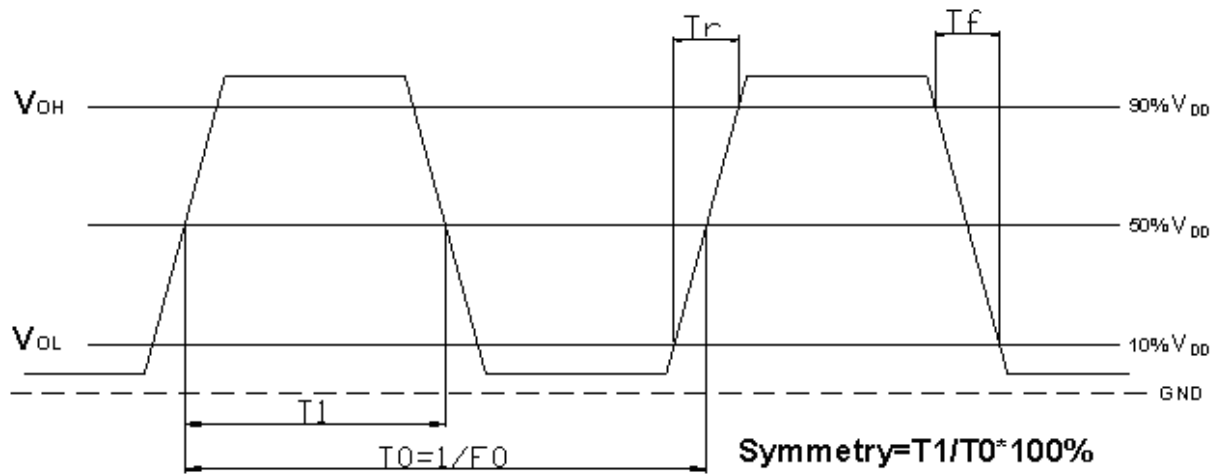
I HCMOS OUTPUT WAVEFORM

I OUTLINE DIMENSIONS (unit: mm)

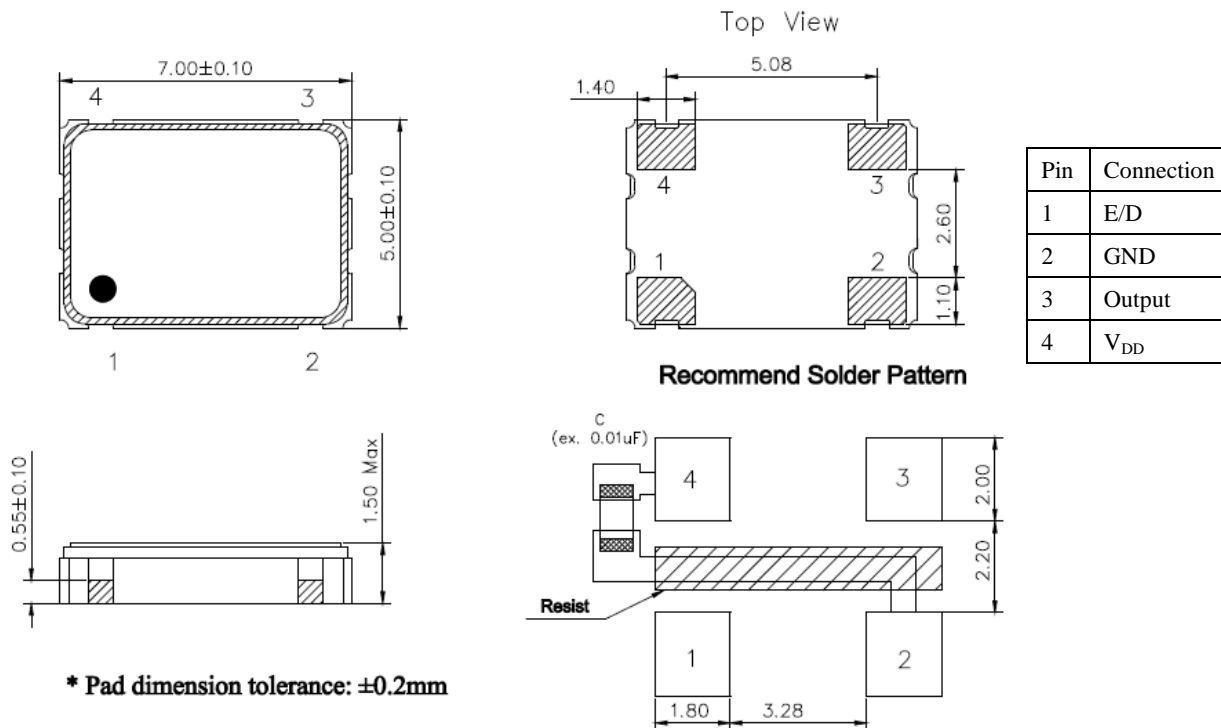

- Note:
- 0.01uF bypass capacitor should be placed between V_{DD} (pin 4) and GND (pin 2) to minimize power supply line noise;
 - Line shouldn't be layed under the oscillator in the PCB to minimize signal interference.
 - The Load we advise is only 15pF (that means drive only 1 CMOS/TTL gate).

I MARKING

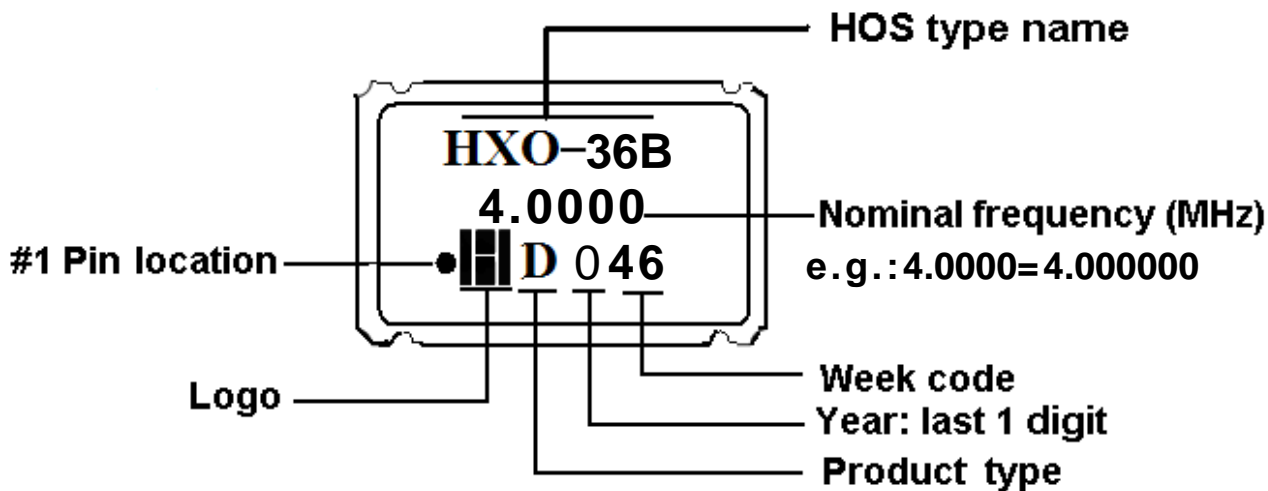

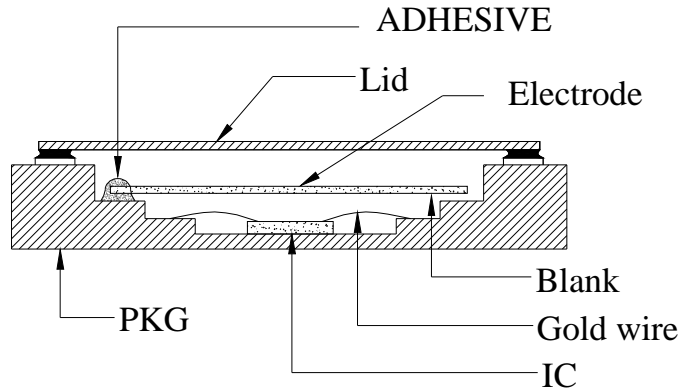
I PRODUCT LAYOUT

NO.	PART	MATERIAL	REMARK
1	LID	KOVAR(Fe+Co+Ni alloy)	
2	PKG	Al ₂ O ₃	Base
3	BLANK	SiO ₂	Quartz
4	ADHESIVE	Ag/Silicon	Support
5	Electrode	Noble metal	
6	IC	Si	
7	Gold wire	Au	Connect

I REFLOW PROFILES

Profiles Feature	Pb-Free Assembly
Average Ramp-up Rate (Ts max to Tp)	3°C/second max.
Preheat	
■ Temperature Min (Ts min)	125°C
■ Temperature Max (Ts max)	200°C
■ Time (ts min to ts max)	60~180 seconds
Time maintained above	
■ Temperature (TL)	217°C
■ Time (tL)	60~150 seconds
Peak/Classification Temperature (Tp)	260°C
Time within 5°C of actual Peak Temperature (tp)	20~40 seconds
Ramp-down rate	6°C/second max.
Time 25°C to Peak Temperature	8 minutes max.
Suggest reflow times	3 Times max

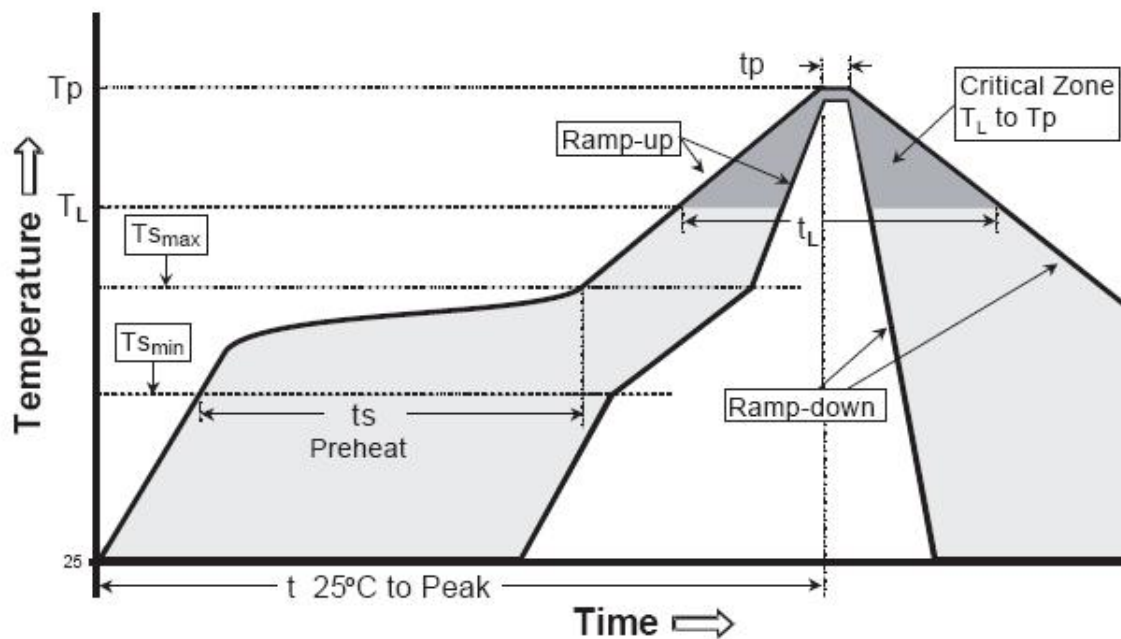

Remark: To reference JEDEC J-STD-020

I PACKAGE(reference to EIA-481)

Tape Dimensions(unit : mm)

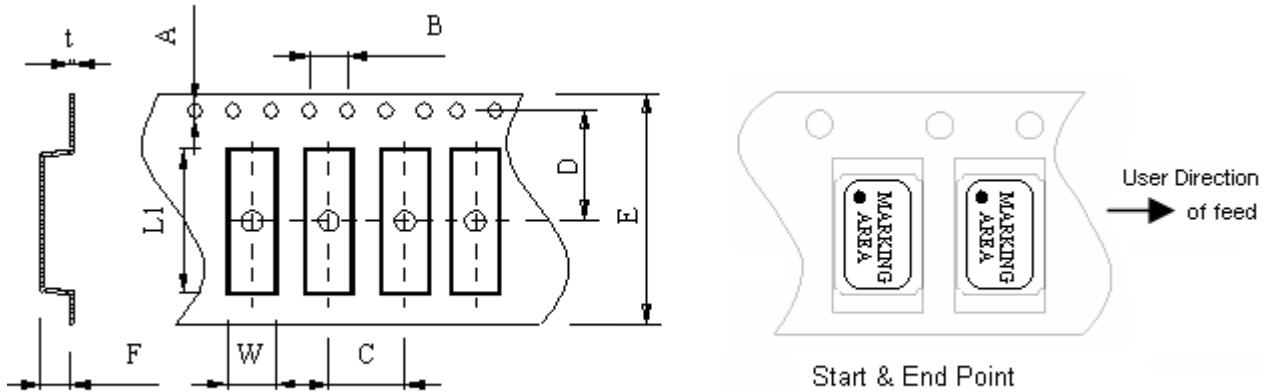

A	B	C	D	E	F	L1	W	t
1.50±0.2	4.0±0.2	8.0±0.1	7.5±0.2	16.0±0.2	2.0	7.4±0.1	5.4±0.1	0.3

Reel Dimensions(unit: mm)

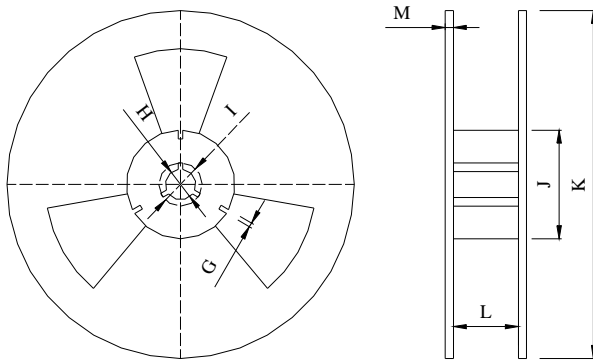

G	H	I	J	K	L	M
2.5	13.5	21.6	60.0	178	17.5	1.6

*1000pcs/Reel

Carton Dimension (unit : mm)

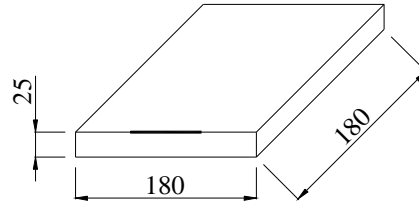
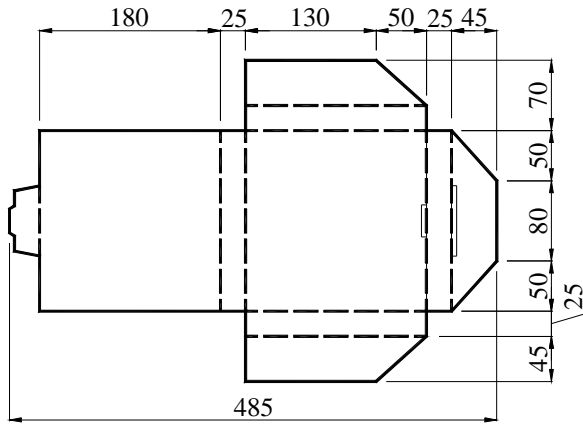

1 reel = 1 Inner box

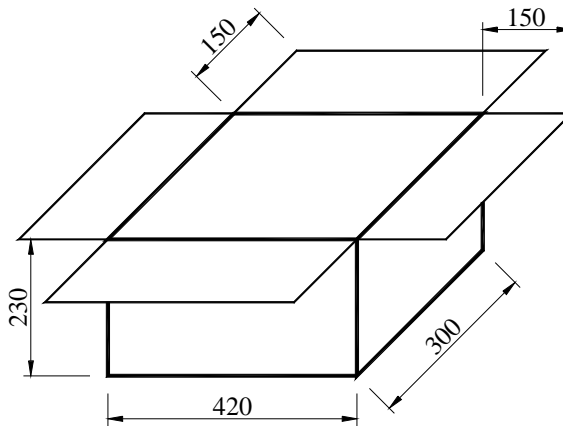
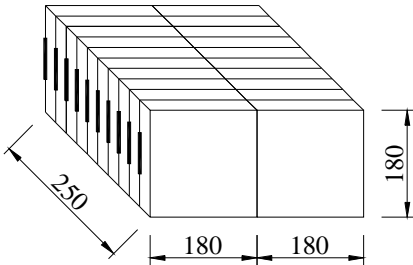

20 Inner boxes = 1 Carton

20kpcs = 1 Carton

I RELIABILITY SPECIFICATIONS

No.	Test Item	Test Conditions	Reference
1	High Temperature Storage	Temperature: 125°C ± 3°C Time: 1000 ± 12 Hours	MIL-STD-202 Method 108
2	Temperature Cycle	Temperature 1: -55°C ± 3°C Temperature 2: 125°C ± 3°C Temperature change between T1 and T2 at soonest Run 1000 cycles, maintain T1 and T2 5minutes each in one cycle	JESD22 Method JA-104
3	Solder Heat Resistance	Pre-heat: 125°C 60~120 Seconds Solder Temperature: 260°C ± 5°C Time: 30 Seconds	MIL-STD-202 Method 210
4	Drop Test	3 Times Free Fall from 150cm height to concrete floor.	IEC 68-2-32
5	High Temperature, High Humidity Storage	Temperature: 85°C ± 5°C Relative Humidity: 80%--85% Time: 250Hours ± 12 Hours	MIL-STD-202 Method 103
6	Steam Aging	Temperature: 97°C ± 3°C Time: 24 Hours 260°C solder pot to check solderability	J-STD-002
7	Solderability	Dip in flux 5~10 seconds Temperature: 245°C ± 5°C Time: 10 Seconds	J-STD-002
8	Aging	Temperature: 85°C ± 2°C Time: 250 ± 12Hours	MIL-STD-202 Method 108
9	Thermal Shock	Temperature 1: -55°C ± 3°C Temperature 2: 125°C ± 3°C Temperature change between T1 and T2: 5 seconds 100 cycles, maintain T1 and T2 for 30 minutes each in one cycle	MIL-STD-202 Method 107
10	Vibration	Frequency Range: 10Hz~2000Hz Amplitude: 1.5mm or 20G 4Hours in each direction, total 12Hours	MIL-STD-202 Method 204