



MBR2040FCT SERIES

20 AMPERES SCHOTTKY BARRIER RECTIFIERS

VOLTAGE 40 to 200 Volts **CURRENT** 20 Amperes

ITO-220AB

Unit : inch(mm)

FEATURES

- Plastic package has Underwriters Laboratory Flammability Classification 94V-O. Flame Retardant Epoxy Molding Compound.
- Metal silicon junction, majority carrier conduction
- Low power loss, high efficiency.
- High current capability
- Guardring for overvoltage protection
- For use in low voltage,high frequency inverters free wheeling , and polarity protection applications.
- Lead free in comply with EU RoHS 2002/95/EC directives

MECHANICAL DATA

- Case: ITO-220AB molded plastic
- Terminals: solder plated, solderable per MIL-STD-750, Method 2026
- Polarity: As marked.
- Mounting Position: Any
- Weight: 0.055 ounces, 1.5615 grams.

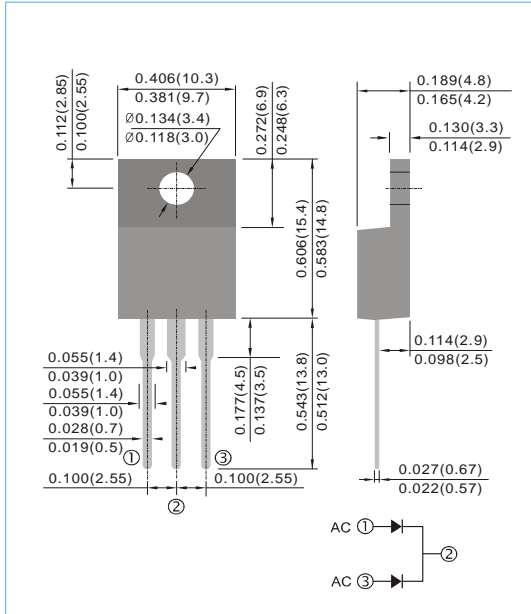

Datasheet.Live

MAXIMUM RATINGS AND ELECTRICAL CHARACTERISTICS

Ratings at 25°C ambient temperature unless otherwise specified. Single phase, half wave, 60 Hz, resistive or inductive load.

For capacitive load, derate current by 20%

PARAMETER	SYMBOL	MBR2040FCT	MBR2045FCT	MBR2050FCT	MBR2060FCT	MBR2080FCT	MBR2090FCT	MBR20100FCT	MBR20150FCT	MBR20200FCT	UNITS
Maximum Recurrent Peak Reverse Voltage	V_{RRM}	40	45	50	60	80	90	100	150	200	V
Maximum RMS Voltage	V_{RMS}	28	31.5	35	42	56	63	70	105	140	V
Maximum DC Blocking Voltage	V_{DC}	40	45	50	60	80	90	100	150	200	V
Maximum Average Forward Current (See fig.1)	$I_{F(AV)}$	20									A
Peak Forward Surge Current : 8.3ms single half sine-wave superimposed on rated load (JEDEC method)	I_{FSM}	200									A
Maximum Forward Voltage at 10A, per leg	V_F	0.7		0.75		0.8		0.9			V
Maximum DC Reverse Current $T_J=25^\circ\text{C}$ at Rated DC Blocking Voltage $T_J=125^\circ\text{C}$	I_R	0.05 20									mA
Typical Thermal Resistance	$R_{\theta JC}$	2									$^\circ\text{C} / \text{W}$
Operating and Storage Junction Temperature Range	T_J, T_{STG}	-55 to +150				-65 to +175					$^\circ\text{C}$

Notes :

Both Bonding and Chip structure are available.



MBR2040FCT SERIES

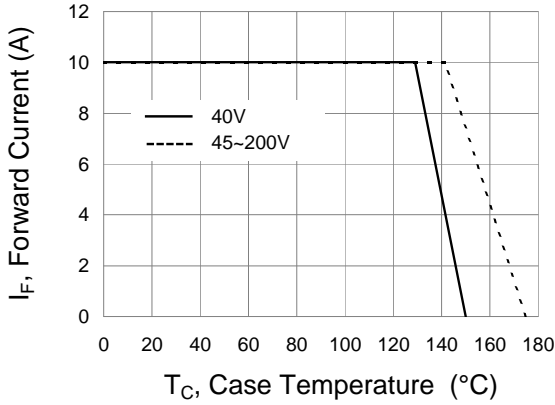

Fig.1 Forward Current Derating Curve

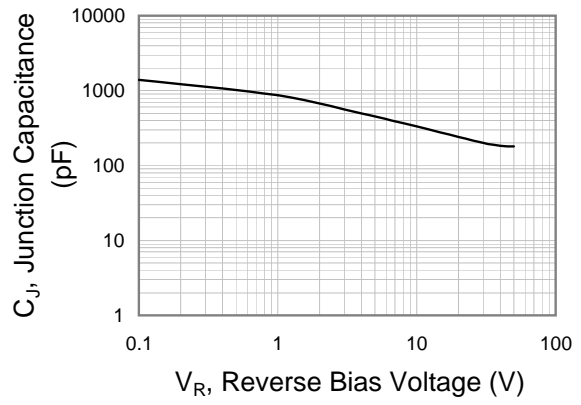

Fig.2 Typical Junction Capacitance

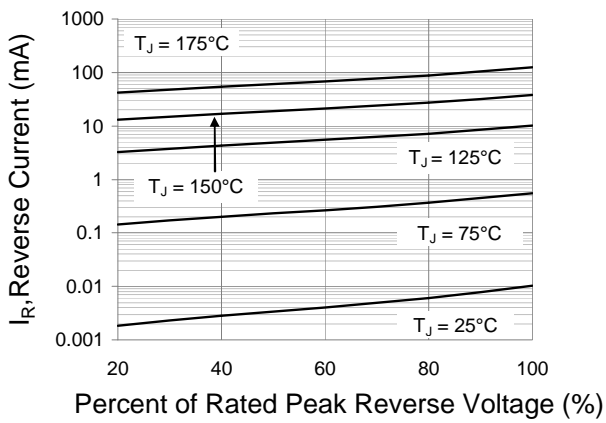

Fig.3 Typical Reverse Characteristics

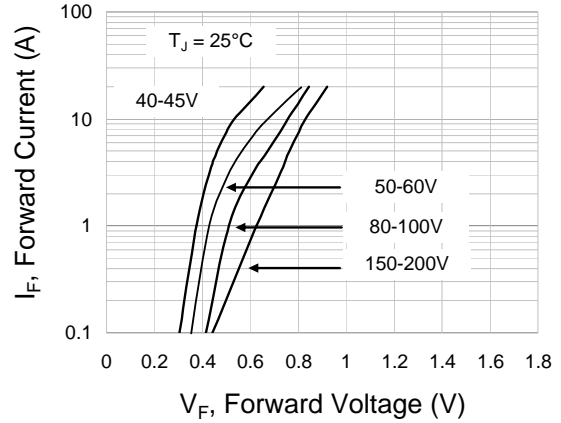

Fig.4 Typical Forward Characteristics



MBR2040FCT SERIES

For example :

RB500V-40_R2_00001



Packing Code XX				Version Code XXXXX		
Packing type	1 st Code	Packing size code	2 nd Code	HF or RoHS	1 st Code	2 nd ~5 th Code
T/B	A	N/A	0	HF	0	serial number
T/R	R	7"	1	RoHS	1	serial number
B/P	B	13"	2			
T/P	T	26mm	X			
TRR	S	52mm	Y			
TRL	L	PBCU	U			
FORMING	F	PBCD	D			

Part No_packing code_Version

MBR2040FCT_T0_00001

MBR2040FCT_T0_10001