

S3C2440A

**32-BIT CMOS
MICROCONTROLLER
USER'S MANUAL**

Revision 1



Important Notice

The information in this publication has been carefully checked and is believed to be entirely accurate at the time of publication. Samsung assumes no responsibility, however, for possible errors or omissions, or for any consequences resulting from the use of the information contained herein.

Samsung reserves the right to make changes in its products or product specifications with the intent to improve function or design at any time and without notice and is not required to update this documentation to reflect such changes.

This publication does not convey to a purchaser of semiconductor devices described herein any license under the patent rights of Samsung or others.

Samsung makes no warranty, representation, or guarantee regarding the suitability of its products for any particular purpose, nor does Samsung assume any liability arising out of the application or use of any product or circuit and specifically disclaims any and all liability, including without limitation any consequential or incidental damages.

**S3C2440A 32-Bit CMOS Microcontroller
User's Manual, Revision 1
Publication Number: 21-S3-C2440A-072004**

© 2004 Samsung Electronics

All rights reserved. No part of this publication may be reproduced, stored in a retrieval system, or transmitted in any form or by any means, electric or mechanical, by photocopying, recording, or otherwise, without the prior written consent of Samsung Electronics.

Samsung Electronics' microcontroller business has been awarded full ISO-14001 certification (BVQ1 Certificate No. 9330). All semiconductor products are designed and manufactured in accordance with the highest quality standards and objectives.

Samsung Electronics Co., Ltd.
San #24 Nongseo-Ri, Giheung- Eup
Yongin-City, Gyeonggi-Do, Korea
C.P.O. Box #37, Suwon 449-900

TEL: (82)-(031)-209-1490
FAX: (82) (331) 209-1909
Home-Page URL: [Http://www.samsungsemi.com/](http://www.samsungsemi.com/)

Printed in the Republic of Korea

"Typical" parameters can and do vary in different applications. All operating parameters, including "Typicals" must be validated for each customer application by the customer's technical experts.

Samsung products are not designed, intended, or authorized for use as components in systems intended for surgical implant into the body, for other applications intended to support or sustain life, or for any other application in which the failure of the Samsung product could create a situation where personal injury or death may occur.

Should the Buyer purchase or use a Samsung product for any such unintended or unauthorized application, the Buyer shall indemnify and hold Samsung and its officers, employees, subsidiaries, affiliates, and distributors harmless against all claims, costs, damages, expenses, and reasonable attorney fees arising out of, either directly or indirectly, any claim of personal injury or death that may be associated with such unintended or unauthorized use, even if such claim alleges that Samsung was negligent regarding the design or manufacture of said product.

Table of Contents

Chapter 1 Product Overview

Introduction.....	1-1
Features.....	1-2
Block Diagram.....	1-5
Pin Assignments.....	1-6
Signal Descriptions.....	1-20
S3C2440A Special Registers.....	1-26

Chapter 2 Programmer's Model

Overview.....	2-1
Processor Operating States.....	2-1
Switching State.....	2-1
Memory Formats.....	2-1
Big-Endian Format.....	2-2
Little-Endian Format.....	2-2
Instruction Length.....	2-2
Operating Modes.....	2-3
Registers.....	2-3
The Program Status Registers.....	2-7
Exceptions.....	2-10
Interrupt Latencies.....	2-15
Reset.....	2-15

Table of Contents (Continued)

Chapter 3 ARM Instruction Set

Instruction Set Summary.....	3-1
Format Summary	3-1
Instruction Summary.....	3-2
The Condition Field.....	3-4
Branch and Exchange (Bx).....	3-5
Instruction Cycle Times.....	3-5
Assembler Syntax	3-5
Using R15 as an Operand	3-5
Branch and Branch with Link (B, BL).....	3-7
The Link Bit	3-7
Instruction Cycle Times.....	3-7
Assembler Syntax	3-8
Data Processing.....	3-9
Cpsr Flags.....	3-11
Shifts	3-12
Immediate Operand Rotates	3-16
Writing to R15.....	3-16
Using R15 as an Operand.....	3-16
TEQ, TST, Cmp and Cmn Opcodes.....	3-16
Instruction Cycle Times.....	3-16
Assembler Syntax	3-17
Examples	3-17
Psr Transfer (MRS, MSR).....	3-18
Operand Restrictions	3-18
Reserved Bits.....	3-20
Examples	3-20
Instruction Cycle Times.....	3-20
Assembly Syntax	3-21
Examples	3-21
Multiply And Multiply-Accumulate (MUL, MLA).....	3-22
Cpsr Flags.....	3-24
Instruction Cycle Times.....	3-24
Assembler Syntax	3-24
Examples	3-24
Multiply Long And Multiply-Accumulate Long (MULL, MLAL)	3-25
Operand Restrictions	3-26
Cpsr Flags.....	3-26
Instruction Cycle Times.....	3-26
Assembler Syntax	3-27
Examples	3-27

Table of Contents (Continued)

Chapter 3 ARM Instruction Set (Continued)

Single Data Transfer (LDR, STR).....	3-28
Offsets and Auto-Indexing	3-29
Shifted Register Offset	3-29
Bytes and Words	3-29
Use of R15.....	3-31
Example	3-31
Data Aborts	3-31
Instruction Cycle Times.....	3-31
Assembler Syntax	3-32
Examples	3-33
Halfword and Signed Data Transfer (LDRH/STRH/LDRSB/LDRSH)	3-34
Offsets and Auto-Indexing	3-35
Halfword Load and Stores.....	3-36
Use of R15.....	3-37
Data Aborts	3-37
Instruction Cycle Times.....	3-37
Assembler Syntax	3-38
Examples	3-39
Block Data Transfer (LDM, STM).....	3-40
The Register List.....	3-40
Addressing Modes.....	3-41
Address Alignment	3-41
Use of the S Bit.....	3-43
Use of R15 as The Base	3-43
Inclusion of the Base in the Register List.....	3-44
Data Aborts	3-44
Instruction Cycle Times.....	3-44
Assembler Syntax.....	3-45
Examples	3-46
Single Data Swap (SWP).....	3-47
Bytes and Words	3-47
Use of R15.....	3-48
Data Aborts	3-48
Instruction Cycle Times.....	3-48
Assembler Syntax	3-48
Software Interrupt (SWI).....	3-49
Return from the Supervisor	3-49
Comment Field.....	3-49
Instruction Cycle Times.....	3-49
Assembler Syntax.....	3-50
Coprocessor Data Operations (CDP).....	3-51
Coprocessor Instructions.....	3-51
Instruction Cycle Times.....	3-52
Examples	3-52

Table of Contents (Continued)

Chapter 3 ARM Instruction Set (Continued)

Coprocessor Data Transfers (LDC, STC).....	3-53
The Coprocessor Fields	3-54
Addressing Modes.....	3-54
Address Alignment	3-54
Data Aborts	3-54
Assembler Syntax.....	3-55
Examples	3-55
Coprocessor Register Transfers (MRC, MCR).....	3-56
The Coprocessor Fields	3-56
Transfers to R15.....	3-57
Transfers from R15	3-57
Instruction Cycle Times.....	3-57
Assembler Syntax.....	3-57
Examples	3-57
Undefined Instruction	3-58
Instruction Cycle Times.....	3-58
Assembler Syntax.....	3-58
Instruction Set Examples	3-59
Using the Conditional Instructions	3-59
Pseudo-Random Binary Sequence Generator.....	3-61
Multiplication by Constant Using the Barrel Shifter.....	3-61
Loading a Word from an Unknown Alignment	3-63

Chapter 4 Thumb Instruction Set

Thumb Instruction Set Format.....	4-1
Format Summary	4-2
Opcode Summary	4-3
Format 1: Move Shifted Register.....	4-5
Operation.....	4-5
Instruction Cycle Times.....	4-6
Examples	4-6
Format 2: Add/Subtract.....	4-7
Operation.....	4-7
Instruction Cycle Times.....	4-8
Examples	4-8
Format 3: Move/Compare/Add/Subtract Immediate.....	4-9
Operations	4-9
Instruction Cycle Times.....	4-10
Examples	4-10

Table of Contents (Continued)

Chapter 4 Thumb Instruction Set (Continued)

Format 4: ALU Operations.....	4-11
Operation.....	4-11
Instruction Cycle Times.....	4-12
Examples	4-12
Format 5: Hi-Register Operations/Branch Exchange	4-13
Operation.....	4-13
Instruction Cycle Times.....	4-14
The BX Instruction	4-14
Examples	4-15
Using R15 As an Operand.....	4-15
Format 6: PC-Relative Load.....	4-16
Operation.....	4-16
Instruction Cycle Times.....	4-17
Examples	4-17
Format 7: Load/Store With Register Offset.....	4-18
Operation.....	4-19
Instruction Cycle Times.....	4-19
Examples	4-19
Format 8: Load/Store Sign-Extended Byte/Halfword.....	4-20
Operation.....	4-20
Instruction Cycle Times.....	4-21
Examples	4-21
Format 9: Load/Store With Immediate Offset.....	4-22
Operation.....	4-23
Instruction Cycle Times.....	4-23
Examples	4-23
Format 10: Load/Store Halfword.....	4-24
Operation.....	4-24
Examples	4-25
Format 11: SP-Relative Load/Store	4-26
Operation.....	4-26
Instruction Cycle Times.....	4-27
Examples	4-27
Format 12: Load Address.....	4-28
Operation.....	4-28
Instruction Cycle Times.....	4-29
Examples	4-29
Format 13: Add Offset to Stack Pointer	4-30
Operation.....	4-30
Instruction Cycle Times.....	4-30
Examples	4-30

Table of Contents (Continued)

Chapter 4 Thumb Instruction Set (Continued)

Format 14: Push/Pop Registers	4-31
Operation.....	4-31
Instruction Cycle Times.....	4-32
Examples	4-32
Format 15: Multiple Load/Store.....	4-33
Operation.....	4-33
Instruction Cycle Times.....	4-33
Examples	4-33
Format 16: Conditional Branch.....	4-34
Operation.....	4-34
Instruction Cycle Times.....	4-35
Examples	4-35
Format 17: Software Interrupt.....	4-36
Operation.....	4-36
Instruction Cycle Times.....	4-36
Examples	4-36
Format 18: Unconditional Branch.....	4-37
Operation.....	4-37
Examples	4-37
Format 19: long branch with link	4-38
Operation.....	4-38
Instruction Cycle Times.....	4-39
Examples	4-39
Instruction Set Examples	4-40
Multiplication by A Constant Using Shifts and Adds.....	4-40
General Purpose Signed Divide.....	4-41
Division by a Constant	4-43

Table of Contents (Continued)

Chapter 5 Memory Controller

Overview	5-1
Function Description	5-4
Bank0 Bus Width	5-4
Memory (SRAM/SDRAM) Address Pin Connections	5-4
Sdram Bank Address Pin Connection Example	5-5
nWAIT Pin Operation	5-6
nXBREQ/nXBACK Pin Operation	5-7
Programmable Access Cycle	5-12
Bus Width & Wait Control Register (Bwscon)	5-14
Bank Control Register (Bankconn: NGCS0-NGCS5)	5-16
Bank Control Register (Bankconn: NGCS6-NGCS7)	5-17
Refresh Control Register	5-18
Banksizes Register	5-19
Sdram Mode Register Set Register (MRSR)	5-20

Chapter 6 Nand Flash Controller

Overview	6-1
Features	6-1
Block Diagram	6-2
Boot Loader Function	6-2
Pin Configuration	6-3
Nand Flash Memory Configuration Table	6-3
Nand Flash Memory Timing	6-4
Software Mode	6-5
Steppingstone (4K-Byte SRAM)	6-6
Ecc (Error Correction Code)	6-7
2048 Byte ECC Parity Code Assignment Table	6-7
16 Byte ECC Parity Code Assignment Table	6-7
ECC Module Features	6-8
ECC Programming Guide	6-8
Nand Flash Memory Mapping	6-9
Nand Flash Memory Configuration	6-10
Nand Flash Configuration Register	6-12
Control Register	6-13
Command Register	6-15
Address Register	6-15
Data Register	6-15
Main Data Area Register	6-16
Spare Area Ecc Register	6-17
NFCON Status Register	6-18
ECC0/1 Status Register	6-19
Main Data Area ECC0 Status Register	6-20
Spare Area ECC Status Register	6-20
Block Address Register	6-21

Table of Contents (Continued)

Chapter 7 Clock & Power Management

Overview	7-1
Functional Description	7-2
Clock Architecture	7-2
Clock Source Selection	7-2
Phase Locked Loop (PLL)	7-4
Clock Control Logic	7-6
Power Management	7-10
Clock Generator & Power Management Special Register	7-20
Lock Time Count Register (LOCKTIME)	7-20
PLL Control Register (MPLLCON & UPLLCON)	7-21
PLL Value Selection Table	7-21
Clock Control Register (CLKCON)	7-22
Clock Slow Control (CLKSLOW) Register	7-23
Clock Divider Control (CLKDIVN) Register	7-24
Camera Clock Divider (CAMDIVN) Register	7-25

Chapter 8 DMA

Overview	8-1
DMA Request Sources	8-2
DMA Operation	8-2
External DMA DREQ/DACK Protocol	8-3
Examples	8-6
DMA Special Registers	8-7
DMA Initial Source (DISRC) Register	8-7
DMA Initial Source Control (DISRCC) Register	8-7
DMA Initial Destination (DIDST) Register	8-8
DMA Initial Destination Control (DIDSTC) Register	8-8
DMA Control (DCON) Register	8-9
DMA Status (DSTAT) Register	8-12
DMA Current Source (DCSRC) Register	8-13
Current Destination (DCDST) Register	8-13
DMA Mask Trigger (DMASKTRIG) Register	8-14

Table of Contents (Continued)

Chapter 9 I/O PORTS

Overview	9-1
Port Control Descriptions	9-7
Port Configuration Register (GPACON-GPJCON).....	9-7
Port Data Register (GPADAT-GPJDAT)	9-7
Port Pull-Up Register (GPBUP-GPJUP).....	9-7
Miscellaneous Control Register.....	9-7
External Interrupt Control Register.....	9-7
I/O Port Control Register	9-8
Port A Control Registers (GPACON, GPADAT)	9-8
Port B Control Registers (GPBCON, GPBDAT, GPBUP).....	9-10
Port C Control Registers (GPCCON, GPCDAT, GPCUP).....	9-11
Port D Control Registers (GPDCON, GPDDAT, GPDUP).....	9-13
Port E Control Registers (GPECON, GPEDAT, GPEUP).....	9-15
Port F Control Registers (GPFCON, GPFDAT)	9-17
Port G Control Registers (GPGCON, GPGDAT)	9-18
Port H Control Registers (GPHCON, GPHDAT)	9-20
Port J Control Registers (GPJCON, GPJDAT)	9-21
Miscellaneous Control Register (MISCCR)	9-23
DCLK Control Registers (DCLKCON).....	9-25
EXTINTn (External Interrupt Control Register n).....	9-26
EINTFLn (External Interrupt Filter Register n).....	9-30
EINTMASK (External Interrupt Mask Register)	9-31
EINTPEND (External Interrupt Pending Register)	9-32
GSTATUSn (General Status Registers)	9-33
DSCn (Drive Strength Control).....	9-34
DSCn (Drive Strength Control).....	9-35
MSLCON (Memory Sleep Control Register).....	9-36

Table of Contents (Continued)

Chapter 10 Basic Timer

Overview	10-1
Feature.....	10-1
PWM Timer Operation	10-3
Prescaler & Divider	10-3
Basic Timer Operation	10-3
Auto Reload & Double Buffering.....	10-4
Timer Initialization Using Manual Update Bit and Inverter Bit	10-5
Timer Operation.....	10-6
Pulse Width Modulation (PWM).....	10-7
Output Level Control	10-8
Dead Zone Generator.....	10-9
DMA Request Mode	10-10
PWM Timer Control Registers	10-11
Timer Configuration Register0 (TCFG0).....	10-11
Timer Configuration Register1 (TCFG1).....	10-12
Timer Control (TCON) Register.....	10-13
Timer 0 Count Buffer Register & Compare Buffer Register (TCNTB0/TCMPB0).....	10-15
Timer 0 Count Observation Register (TCNTO0).....	10-15
Timer 1 Count Buffer Register & Compare Buffer Register (TCNTB1/TCMPB1).....	10-16
Timer 1 Count Observation Register (TCNTO1).....	10-16
Timer 2 Count Buffer Register & Compare Buffer Register (TCNTB2/TCMPB2).....	10-17
Timer 2 Count Observation Register (TCNTO2).....	10-17
Timer 3 Count Buffer Register & Compare Buffer Register (TCNTB3/TCMPB3).....	10-18
Timer 3 Count Observation Register (TCNTO3).....	10-18
Timer 4 Count Buffer Register (TCNTB4).....	10-19
Timer 4 Count Observation Register (TCNTO4).....	10-19

Table of Contents (Continued)

Chapter 11 UART

Overview	11-1
Features	11-1
Block Diagram	11-2
Uart Operation.....	11-3
Uart Special Registers	11-10
Uart Line Control Register	11-10
Uart Control Register	11-11
Uart FIFO Control Register	11-14
Uart Modem Control Register.....	11-15
Uart Tx/Rx Status Register.....	11-16
Uart Error Status Register	11-17
Uart FIFO Status Register.....	11-18
Uart Modem Status Register	11-19
Uart Transmit Buffer Register (HOLDING Register & FIFO Register)	11-20
Uart Receive Buffer Register (HOLDING Register & FIFO Register)	11-20
Uart Baud Rate Divisor Register.....	11-21

Chapter 12 USB HOST Controller

Overview	12-1
Usb Host Controller Special Registers	12-2
OHCI Registers for Usb Host Controller	12-2

Table of Contents (Continued)

Chapter 13 USB Device Controller

Overview	13-1
Feature	13-1
Usb Device Controller Special Registers	13-3
Function Address Register (FUNC_ADDR_REG)	13-5
Power Management Register (PWR_REG)	13-6
Interrupt Register (EP_INT_REG/USB_INT_REG)	13-7
Interrupt Enable Register (EP_INT_EN_REG/USB_INT_EN_REG)	13-9
Frame Number Register (FPAME_NUM1_REG/FRAME_NUM2_REG)	13-10
Index Register (INDEX_REG)	13-11
MAX Packet Register (MAXP_REG)	13-11
END Point0 Control Status Register (EP0_CSR)	13-12
END Point In Control Status Register (IN_CSR1_REG/IN_CSR2_REG)	13-13
END Point Out Control Status Register (OUT_CSR1_REG/OUT_CSR2_REG)	13-15
END Point Out Write Count Register (OUT_FIFO_CNT1_REG/OUT_FIFO_CNT2_REG)	13-17
END Point FIFO Register (EPN_FIFO_REG)	13-17
DMA Interface Control Register (EPN_DMA_CON)	13-18
DMA Unit Counter Register (EPN_DMA_UNIT)	13-19
DMA FIFO Counter Register (EPN_DMA_FIFO)	13-20
DMA Total Transfer Counter Register (EPn_DMA_TTC_L, M, H)	13-21

Chapter 14 Interrupt Controller

Overview	14-1
Interrupt Controller Operation	14-2
Interrupt Sources	14-3
Interrupt Sub Sources	14-4
Interrupt Priority Generating Block	14-5
Interrupt Priority	14-6
Interrupt Controller Special Registers	14-7
Source Pending (SRCPND) Register	14-7
Interrupt Mode (INTMOD) Register	14-9
Interrupt Mask (INTMSK) Register	14-11
Priority Register (PRIORITY)	14-13
Interrupt Pending (INTPND) Register	14-14
Interrupt Offset (INTOFFSET) Register	14-16
Sub Source Pending (SUBSRCPND) Register	14-17
Interrupt Sub Mask (INTSUBMSK) Register	14-18

Table of Contents (Continued)

Chapter 15 LCD Controller

Overview	15-1
Features	15-1
Common Features	15-2
External Interface Signal	15-2
Block Diagram	15-3
STN LCD Controller Operation	15-4
Timing Generator (TIMEGEN)	15-4
Video Operation	15-5
Dithering and Frame Rate Control	15-7
Memory Data Format (STN, BSWP = 0)	15-9
TFT LCD Controller Operation	15-16
Video Operation	15-16
Memory Data Format (TFT)	15-17
256 Palette Usage (TFT)	15-21
Samsung TFT LCD Panel (3.5" PORTRAIT/256K COLOR/REFLECTIVE A-SI/TRANSFLECTIVE A-SI TFT LCD)	15-24
Virtual Display (TFT/STN)	15-25
LCD Power Enable (STN/TFT)	15-26
LCD Controller Special Registers	15-27
Frame Buffer Start Address 1 Register	15-33

Chapter 16 ADC & Touch Screen Interface

Overview	16-1
Features	16-1
ADC & Touch Screen Interface Operation	16-2
Block Diagram	16-2
Function Descriptions	16-3
ADC AND Touch Screen Interface Special Registers	16-5
ADC Control Register (ADCCON)	16-5
ADC Touch Screen Control Register (ADCTSC)	16-6
ADC Start Delay Register (ADCDLY)	16-7
ADC Conversion Data Register (ADCDAT0)	16-8
ADC Conversion Data Register (ADCDAT1)	16-9
ADC Touch Screen Up-Down INT Check Register (ADCUPDN)	16-9

Table of Contents (Continued)

Chapter 17 Real Time Clock

Overview	17-1
Features	17-1
Real Time Clock Operation	17-2
Leap Year Generator	17-2
Read/Write Registers	17-2
Backup Battery Operation	17-2
Alarm Function	17-3
TICK Time Interrupt	17-3
32.768kHz X-Tal Connection Example	17-3
Real Time Clock Special Registers	17-4
Real Time Clock Control (RTCCON) Register	17-4
TICK Time Count (TICNT) Register	17-4
RTC Alarm Control (RTCALM) Register	17-5
ALARM Second Data (ALMSEC) Register	17-6
ALARM Min Data (ALMMIN) Register	17-6
ALARM Hour Data (ALMHOUR) Register	17-6
ALARM Date Data (ALMDATE) Register	17-7
ALARM Mon Data (ALMMON) Register	17-7
ALARM Year Data (ALMYEAR) Register	17-7
BCD Second (BCDSEC) Register	17-8
BCD Minute (BCDMIN) Register	17-8
BCD Hour (BCDHOURL) Register	17-8
BCD Date (BCDDATE) Register	17-9
BCD Day (BCDDAY) Register	17-9
BCD Month (BCDMON) Register	17-9
BCD Year (BCDYEAR) Register	17-10

Chapter 18 Watchdog Timer

Overview	18-1
Features	18-1
Watchdog Timer Operation	18-2
Wtdat & Wtcnt	18-2
Consideration of Debugging Environment	18-2
Watchdog Timer Special Registers	18-3
Watchdog Timer Control (WTCN) Register	18-3
Watchdog Timer Data (WTDAT) Register	18-4
Watchdog Timer Count (WTCNT) Register	18-4

Table of Contents (Continued)

Chapter 19 MMC/SD/SDIO Controller

Features	19-1
Block Diagram	19-1
SD Operation	19-2
SDIO Operation	19-3
SDI Special Registers	19-4
SDI Control Register (SDICON)	19-4
SDI Baud Rate Prescaler Register (SDIPRE)	19-4
SDI Command Argument Register (SDICmdArg)	19-5
SDI Command Control Register (SDICmdCon)	19-5
SDI Command Status Register (SDICmdSta)	19-6
SDI Response Register 0 (SDIRSP0)	19-6
SDI Response Register 1 (SDIRSP1)	19-6
SDI Response Register 2 (SDIRSP2)	19-7
SDI Response Register 3 (SDIRSP3)	19-7
SDI Data / Busy Timer Register (SDIDTimer)	19-7
SDI Block Size Register (SDIBSize)	19-7
SDI Data Control Register (SDIDatCon)	19-8
SDI Data Remain Counter Register (ADIDatCnt)	19-9
SDI Data Status Register (ADIDatSta)	19-9
SDI FIFO Status Register (SDIFSTA)	19-10
SDI Interrupt Mask Register (SDIIntMsk)	19-11
SDI Data Register (SDIDAT)	19-12

Chapter 20 IIC-Bus Interface

Overview	20-1
IIC-Bus Interface	20-3
Start and Stop Conditions	20-3
Data Transfer Format	20-4
ACK Signal Transmission	20-5
Read-Write Operation	20-6
Bus Arbitration Procedures	20-6
Abort Conditions	20-6
Configuring IIC-Bus	20-6
Flowcharts of Operations in Each Mode	20-7
IIC-Bus Interface Special Registers	20-11
Multi-Master IIC-Bus Control (IICCON) Register	20-11
Multi-Master IIC-Bus Control/Status (IICSTAT) Register	20-12
Multi-Master IIC-Bus Address (IICADD) Register	20-13
Multi-Master IIC-Bus Transmit/Receive Data Shift (IICDS) Register	20-13
Multi-Master IIC-Bus Line Control (IICLC) Register	20-14

Table of Contents (Continued)

Chapter 21 IIS-Bus Interface

Overview	21-1
Block Diagram	21-2
Functional Descriptions.....	21-2
Transmit or Receive Only Mode	21-2
Dma Transfer	21-3
Transmit and Receive Mode.....	21-3
Audio Serial Interface Format.....	21-3
IIS-Bus Format	21-3
MSB (Left) Justified	21-3
Sampling Frequency and Master Clock	21-4
IIS-Bus Interface Special Registers	21-5
IIS Control (IISCON) Register.....	21-5
IIS Mode Register (IISMOD) Register.....	21-6
IIS Prescaler (IISPSR) Register.....	21-7
IIS FIFO Control (IISFCON) Register.....	21-8
IIS FIFO (IISFIFO) Register.....	21-8

Chapter 22 SPI

Overview	22-1
Features	22-1
Block Diagram	22-2
SPI Operation	22-3
Programming Procedure.....	22-3
SPI Transfer Format.....	22-4
Transmitting Procedure for DMA	22-5
Receiving Procedure for DMA	22-5
SPI Special Registers	22-6
SPI Control Register	22-6
SPI Status Register.....	22-7
SPI Pin Control Register	22-8
SPI Baud Rate Prescaler Register	22-9
SPI Tx Data Register	22-9
SPI Rx Data Register.....	22-9

Table of Contents (Continued)

Chapter 23 Camera Interface

Overview	23-1
Features	23-1
Block Diagram	23-2
Timing Diagram	23-3
Camera Interface Operation	23-5
Two DMA Paths	23-5
Clock Domain	23-5
Frame Memory Hierarchy	23-6
Memory Storing Method	23-8
Timing Diagram for Register Setting	23-9
Timing Diagram for Last IRQ	23-10
Camera Interface Special Registers	23-11
Source Format Register	23-11
Window Option Register	23-12
Global Control Register	23-13
Y1 Start Address Register	23-13
Y2 Start Address Register	23-13
Y3 Start Address Register	23-14
Y4 Start Address Register	23-14
CB1 Start Address Register	23-14
CB2 Start Address Register	23-14
CB3 Start Address Register	23-15
CB4 Start Address Register	23-15
CR1 Start Address Register	23-15
CR2 Start Address Register	23-15
CR3 Start Address Register	23-16
CR4 Start Address Register	23-16
Codec Target Format Register	23-17
Codec Dma Control Register	23-19
Register Setting Guide for Codec Scaler and Preview Scaler	23-20
Codec Pre-Scaler Control Register 1	23-21
Codec Pre-Scaler Control Register 2	23-21
Codec Main-Scaler Control Register	23-22
Codec Dma Target Area Register	23-22
Codec Status Register	23-23
RGB1 Start Address Register	23-23
RGB2 Start Address Register	23-23
RGB3 Start Address Register	23-24
RGB4 Start Address Register	23-24
Preview Target Format Register	23-24
Preview DMA Control Register	23-25

Table of Contents (Continued)

Chapter 23 Camera Interface (Continued)

Preview Pre-Scaler Control Register 1	23-25
Preview Pre-Scaler Control Register 2	23-26
Preview Main-Scaler Control Register	23-26
Preview DMA Target Area Register.....	23-26
Preview Status Register	23-27
Image Capture Enable Register.....	23-27

Chapter 24 AC97 Controller

Overview	24-1
Features	24-1
AC97 Controller Operation.....	24-2
Block Diagram	24-2
Internal Data Path.....	24-3
Operation Flow Chart	24-4
AC-Link Digital Interface Protocol.....	24-5
AC-Link Output Frame (SDATA_OUT)	24-6
AC-Link Input Frame (SDATA_IN)	24-6
AC97 Powerdown	24-7
AC97 Controller Special Registers	24-9
AC97 Global Control Register (AC_GLBCTRL)	24-9
AC97 Global Status Register (AC_GLBSTAT)	24-10
AC97 Codec Command Register (AC_CODEC_CMD).....	24-10
AC97 Codec Status Register (AC_CODEC_STAT)	24-11
AC97 PCM Out/In Channel FIFO Address Register (AC_PCMADDR)	24-11
AC97 MIC in Channel FIFO Address Register (AC_MICADDR)	24-12
AC97 PCM Out/In Channel FIFO Data Register (AC_PCMDATA).....	24-12
AC97 MIC in Channel FIFO Data Register (AC_MICDATA).....	24-12

Table of Contents (Continued)

Chapter 25 Bus Priorities

Overview	25-1
Bus Priority Map	25-1

Chapter 26 Mechanical Data

Package Dimensions	26-1
--------------------------	------

Chapter 27 Electrical Data

Absolute Maximum Ratings	27-1
Recommended Operating Conditions	27-2
D.C. Electrical Characteristics	27-3
A.C. Electrical Characteristics	27-8

List of Figures

Figure Number	Title	Page Number
1-1	S3C2440A Block Diagram.....	1-5
1-2	S3C2440A Pin Assignments (289-FBGA).....	1-6
2-1	Big-Endian Addresses of Bytes within Words.....	2-2
2-2	Little-Endian Addresses of Bytes within Words	2-2
2-3	Register Organization in ARM State.....	2-4
2-4	Register Organization in THUMB state	2-5
2-5	Mapping of THUMB State Registers onto ARM State Registers	2-6
2-6	Program Status Register Format.....	2-7
3-1	ARM Instruction Set Format	3-1
3-2	Branch and Exchange Instructions	3-5
3-3	Branch Instructions.....	3-7
3-4	Data Processing Instructions	3-9
3-5	ARM Shift Operations	3-12
3-6	Logical Shift Left.....	3-12
3-7	Logical Shift Right	3-13
3-8	Arithmetic Shift Right.....	3-13
3-9	Rotate Right.....	3-14
3-10	Rotate Right Extended.....	3-14
3-11	PSR Transfer	3-19
3-12	Multiply Instructions.....	3-22
3-13	Multiply Long Instructions.....	3-25
3-14	Single Data Transfer Instructions.....	3-28
3-15	Little-Endian Offset Addressing.....	3-30
3-16	Halfword and Signed Data Transfer with Register Offset.....	3-34
3-17	Halfword and Signed Data Transfer with Immediate Offset and Auto-Indexing.....	3-35
3-18	Block Data Transfer Instructions	3-40
3-19	Post-Increment Addressing	3-41
3-20	Pre-Increment Addressing	3-42
3-21	Post-Decrement Addressing.....	3-42
3-22	Pre-Decrement Addressing.....	3-43
3-23	Swap Instruction.....	3-47
3-24	Software Interrupt Instruction	3-49
3-25	Coprocessor Data Operation Instruction.....	3-51
3-26	Coprocessor Data Transfer Instructions	3-53
3-27	Coprocessor Register Transfer Instructions	3-56
3-28	Undefined Instruction	3-58

List of Figures (Continued)

Figure Number	Title	Page Number
4-1	THUMB Instruction Set Formats	4-2
4-2	Format 1.....	4-5
4-3	Format 2.....	4-7
4-4	Format 3.....	4-9
4-5	Format 4.....	4-11
4-6	Format 5.....	4-13
4-7	Format 6.....	4-16
4-8	Format 7.....	4-18
4-9	Format 8.....	4-20
4-10	Format 9.....	4-22
4-11	Format 10.....	4-24
4-12	Format 11.....	4-26
4-13	Format 12.....	4-28
4-14	Format 13.....	4-30
4-15	Format 14.....	4-31
4-16	Format 15.....	4-33
4-17	Format 16.....	4-34
4-18	Format 17.....	4-36
4-19	Format 18.....	4-37
4-20	Format 19.....	4-38
5-1	S3C2440A Memory Map after Reset	5-2
5-2	S3C2440A External nWAIT Timing Diagram (Tacc=4)	5-6
5-3	S3C2440A nXBREQ/nXBACK Timing Diagram	5-7
5-4	Memory Interface with 8-bit ROM	5-8
5-5	Memory Interface with 8-bit ROM x 2.....	5-8
5-6	Memory Interface with 8-bit ROM x 4.....	5-9
5-7	Memory Interface with 16-bit ROM	5-9
5-8	Memory Interface with 16-bit SRAM	5-10
5-9	Memory Interface with 16-bit SRAM x 2.....	5-10
5-10	Memory Interface with 16-bit SDRAM (4Mx16, 4banks).....	5-11
5-11	Memory Interface with 16-bit SDRAM (4Mx16x4Bank * 2ea).....	5-11
5-12	S3C2440A nGCS Timing Diagram.....	5-12
5-13	S3C2440A SDRAM Timing Diagram.....	5-13

List of Figures (Continued)

Figure Number	Title	Page Number
6-1	NAND Flash Controller Block Diagram.....	6-2
6-2	NAND Flash Controller Boot Loader Block Diagram	6-2
6-3	CLE & ALE Timing (TACLS=1, TWRPH0=0, TWRPH1=0).....	6-4
6-4	nWE & nRE Timing (TWRPH0=0, TWRPH1=0).....	6-4
6-5	NAND Flash Memory Mapping.....	6-9
6-6	A 8-bit NAND Flash Memory Interface.....	6-10
6-7	Two 8-bit NAND Flash Memory Interface.....	6-10
6-8	A 16-bit NAND Flash Memory Interface	6-11
7-1	Clock Generator Block Diagram.....	7-3
7-2	PLL (Phase-Locked Loop) Block Diagram	7-5
7-3	Main Oscillator Circuit Examples	7-5
7-4	Power-On Reset Sequence (when the external clock source is a crystal oscillator)	7-6
7-5	Changing Slow Clock by Setting PMS Value.....	7-7
7-6	Example of Internal Clock Change.....	7-8
7-7	The Clock Distribution Block Diagram.....	7-10
7-8	Power Management State Diagram	7-11
7-9	Issuing Exit_from_Slow_mode Command in PLL on State.....	7-13
7-10	Issuing Exit_from_Slow_mode Command After Lock Time.....	7-13
7-11	Issuing Exit_from_Slow_mode Command and the Instant PLL_on Command Simultaneously.....	7-14
7-12	SLEEP Mode.....	7-17
8-1	Basic DMA Timing Diagram.....	8-3
8-2	Demand/Handshake Mode Comparison	8-4
8-3	Burst 4 Transfer Size.....	8-5
8-4	Single service in Demand Mode with Unit Transfer Size.....	8-6
8-5	Single service in Handshake Mode with Unit Transfer Size	8-6
8-6	Whole service in Handshake Mode with Unit Transfer Size.....	8-6
10-1	16-bit PWM Timer Block Diagram	10-2
10-2	Timer Operations	10-3
10-3	Example of Double Buffering Function	10-4
10-4	Example of a Timer Operation.....	10-6
10-5	Example of PWM.....	10-7
10-6	Inverter On/Off	10-8
10-7	The Wave Form When a Dead Zone Feature is Enabled.....	10-9
10-8	Timer4 DMA Mode Operation.....	10-10

List of Figures (Continued)

Figure Number	Title	Page Number
11-1	UART Block Diagram (with FIFO).....	11-2
11-2	UART AFC interface	11-4
11-3	Example showing UART Receiving 5 Characters with 2 Errors	11-6
11-4	IrDA Function Block Diagram.....	11-8
11-5	Serial I/O Frame Timing Diagram (Normal UART).....	11-9
11-6	Infrared Transmit Mode Frame Timing Diagram.....	11-9
11-7	Infrared Receive Mode Frame Timing Diagram	11-9
11-8	nCTS and Delta CTS Timing Diagram	11-19
12-1	USB Host Controller Block Diagram	12-1
13-1	USB Device Controller Block Diagram	13-2
14-1	Interrupt Process Diagram.....	14-1
14-2	Priority Generating Block	14-5
15-1	LCD Controller Block Diagram	15-3
15-2	Monochrome Display Types (STN)	15-12
15-3	Color Display Types (STN)	15-13
15-4	8-bit Single Scan Display Type STN LCD Timing	15-15
15-5	16BPP Display Types (TFT)	15-22
15-6	TFT LCD Timing Example.....	15-23
15-7	Example of Scrolling in Virtual Display (Single Scan).....	15-25
15-8	Example of PWREN Function (PWREN=1, INV PWREN=0)	15-26
16-1	ADC and Touch Screen Interface Functional Block Diagram	16-2
16-2	ADC and Touch Screen Operation signal	16-4
17-1	Real Time Clock Block Diagram.....	17-2
17-2	Main Oscillator Circuit Example.....	17-3
18-1	Watchdog Timer Block Diagram.....	18-2
19-1	SD Interface Block Diagram.....	19-1
20-1	IIC-Bus Block Diagram.....	20-2
20-2	Start and Stop Condition	20-3
20-3	IIC-Bus Interface Data Format	20-4
20-4	Data Transfer on the IIC-Bus	20-5
20-5	Acknowledge on the IIC-Bus	20-5
20-6	Operations for Master/Transmitter Mode	20-7
20-7	Operations for Master/Receiver Mode	20-8
20-8	Operations for Slave/Transmitter Mode	20-9
20-9	Operations for Slave/Receiver Mode	20-10

List of Figures (Continued)

Figure Number	Title	Page Number
21-1	IIS-Bus Block Diagram.....	21-2
21-2	IIS-Bus and MSB (Left)-justified Data Interface Formats	21-4
22-1	SPI Block Diagram	22-2
22-2	SPI Transfer Format.....	22-4
23-1	CAMIF Overview	23-2
23-2	ITU-R BT 601 Input Timing Diagram.....	23-3
23-3	ITU-R BT 656 Input Timing Diagram.....	23-3
23-4	Two DMA Paths	23-5
23-5	CAMIF Clock Generation.....	23-6
23-6	Ping-Pong Memory Hierarchy	23-7
23-7	Memory Storing Style	23-8
23-8	Timing Diagram for Register Setting	23-9
23-9	Timing diagram for last IRQ	23-10
23-10	Window Offset Scheme.....	23-12
23-11	Image Mirror and Rotation	23-18
23-12	Scaling Scheme.....	23-20
24-1	AC97 Block Diagram	24-2
24-2	Internal Data Path.....	24-3
24-3	AC97 Operation Flow Chart	24-4
24-4	Bi-directional AC-link Frame with Slot Assignments.....	24-5
24-5	AC-link Output Frame	24-6
24-6	AC-link Input Frame.....	24-6
24-7	AC97 Powerdown Timing Diagram.....	24-7
24-8	AC97 Power down/Power up Flow.....	24-8
26-1	289-FBGA-1414 Package Dimension 1 (Top View)	26-1
26-2	289-FBGA-1414 Package Dimension 2 (Bottom View)	26-2
27-1	Power Consumption Example Comparison when Applied DVS Scheme.....	27-7
27-2	XTIpll Clock Timing Diagram	27-8
27-3	EXTCLK Clock Input Timing Diagram.....	27-8
27-4	EXTCLK/HCLK in case when EXTCLK is used Without the PLL	27-8
27-5	HCLK/CLKOUT/SCLK in case when EXTCLK is used	27-9
27-6	Manual Reset Input Timing Diagram	27-9
27-7	Power-On Oscillation Setting Timing Diagram	27-10
27-8	Sleep Mode Return Oscillation Setting Timing Diagram.....	27-11
27-9	ROM/SRAM Burst READ Timing Diagram (I) (Tacs=0, Tcos=0, Tacc=2, Toch=0, Tcah=0, PMC=0, ST=0, DW=16bit).....	27-12
27-10	ROM/SRAM Burst READ Timing Diagram (II) (Tacs=0, Tcos=0, Tacc=2, Toch=0, Tcah=0, PMC=0, ST=1, DW=16bit).....	27-13

List of Figures (Continued)

Figure Number	Title	Page Number
27-11	External Bus Request in ROM/SRAM Cycle (Tacs=0, Tcos=0, Tacc=8, Toch=0, Tcah=0, PMC=0, ST=0)	27-14
27-12	ROM/SRAM READ Timing Diagram (I) (Tacs=2, Tcos=2, Tacc=4, Toch=2, Tcah=2, PMC=0, ST=0)	27-15
27-13	ROM/SRAM READ Timing Diagram (II) (Tacs=2, Tcos=2, Tacc=4, Toch=2, Tcah=2cycle, PMC=0, ST=1)	27-16
27-14	ROM/SRAM WRITE Timing Diagram (I) (Tacs=2, Tcos=2, Tacc=4, Toch=2, Tcah=2, PMC=0, ST=0)	27-17
27-15	ROM/SRAM WRITE Timing Diagram (II) (Tacs=2, Tcos=2, Tacc=4, Toch=2, Tcah=2, PMC=0, ST=1)	27-18
27-16	External nWAIT READ Timing Diagram (Tacs=0, Tcos=0, Tacc=6, Toch=0, Tcah=0, PMC=0, ST=0)	27-19
27-17	External nWAIT WRITE Timing Diagram (Tacs=0, Tcos=0, Tacc=4, Toch=0, Tcah=0, PMC=0, ST=0)	27-19
27-18	Masked-ROM Single READ Timing Diagram (Tacs=2, Tcos=2, Tacc=8, PMC=01/10/11)	27-20
27-19	Masked-ROM Consecutive READ Timing Diagram (Tacs=0, Tcos=0, Tacc=3, Tpac=2, PMC=01/10/11)	27-20
27-20	SDRAM Single Burst READ Timing Diagram (Trp=2, Trcd=2, Tcl=2, DW=16bit)	27-21
27-21	External Bus Request in SDRAM Timing Diagram (Trp=2, Trcd=2, Tcl=2)	27-22
27-22	SDRAM MRS Timing Diagram	27-23
27-23	SDRAM Single READ Timing Diagram (I) (Trp=2, Trcd=2, Tcl=2)	27-24
27-24	SDRAM Single READ Timing Diagram (II) (Trp=2, Trcd=2, Tcl=3)	27-25
27-25	SDRAM Auto Refresh Timing Diagram (Trp=2, Trc=4)	27-26
27-26	SDRAM Page Hit-Miss READ Timing Diagram (Trp=2, Trcd=2, Tcl=2)	27-27
27-27	SDRAM Self Refresh Timing Diagram (Trp=2, Trc=4)	27-28
27-28	SDRAM Single Write Timing Diagram (Trp=2, Trcd=2)	27-29
27-29	SDRAM Page Hit-Miss Write Timing Diagram (Trp=2, Trcd=2, Tcl=2)	27-30
27-30	External DMA Timing Diagram (Handshake, Single transfer)	27-31
27-31	TFT LCD Controller Timing Diagram	27-31
27-32	IIS Interface Timing Diagram	27-32
27-33	IIC Interface Timing Diagram	27-32
27-34	SD/MMC Interface Timing Diagram	27-33
27-35	SPI Interface Timing Diagram (CPHA=1, CPOL=1)	27-33
27-36	NAND Flash Address/Command Timing Diagram	27-34
27-37	NAND Flash Timing Diagram	27-34

List of Tables

Table Number	Title	Page Number
1-1	289-Pin FBGA Pin Assignments – Pin Number Order (Sheet 1 of 3).....	1-7
1-2	S3C2440A 289-Pin FBGA Pin Assignments (Sheet 1 of 9).....	1-10
1-3	S3C2440A Signal Descriptions (Sheet 1 of 6).....	1-20
1-4	S3C2440A Special Registers (Sheet 1 of 14)	1-26
2-1	PSR Mode Bit Values	2-9
2-2	Exception Entry/Exit.....	2-11
2-3	Exception Vectors	2-13
3-1	The ARM Instruction Set	3-2
3-2	Condition Code Summary.....	3-4
3-3	ARM Data Processing Instructions.....	3-11
3-4	Incremental Cycle Times	3-16
3-5	Assembler Syntax Descriptions	3-27
3-6	Addressing Mode Names	3-45
4-1	THUMB Instruction Set Opcodes	4-3
4-2	Summary of Format 1 Instructions	4-5
4-3	Summary of Format 2 Instructions	4-7
4-4	Summary of Format 3 Instructions	4-9
4-5	Summary of Format 4 Instructions	4-11
4-6	Summary of Format 5 Instructions	4-13
4-7	Summary of PC-Relative Load Instruction	4-16
4-8	Summary of Format 7 Instructions	4-19
4-9	Summary of Format 8 Instructions	4-20
4-10	Summary of Format 9 Instructions	4-23
4-11	Halfword Data Transfer Instructions	4-24
4-12	SP-Relative Load/Store Instructions	4-26
4-13	Load Address.....	4-28
4-14	The ADD SP Instruction.....	4-30
4-15	PUSH and POP Instructions.....	4-31
4-16	The Multiple Load/Store Instructions.....	4-33
4-17	The Conditional Branch Instructions	4-34
4-18	The SWI Instruction	4-36
4-19	Summary of Branch Instruction.....	4-37
4-20	The BL Instruction	4-39
5-1	Bank 6/7 Addresses	5-3
5-2	SDRAM Bank Address Configuration Example.....	5-5
7-1	Clock Source Selection at Boot-Up	7-2
7-2	Clock and Power State in Each Power Mode	7-11
7-3	CLKSLOW and CLKDIVN Register Settings for SLOW Clock example.....	7-12
7-4	Pin configuration table in Sleep mode.....	7-16

List of Tables (Continued)

Table Number	Title	Page Number
8-1	DMA Request Sources for Each Channel.....	8-2
9-1	S3C2440A Port Configuration (Sheet 1 of 5).....	9-2
11-1	Interrupts in Connection with FIFO	11-5
15-1	Relation Between VCLK and CLKVAL (STN, HCLK = 60MHz).....	15-5
15-2	Dither Duty Cycle Examples.....	15-7
15-3	Relation between VCLK and CLKVAL (TFT, HCLK = 60MHz).....	15-16
15-4	5:6:5 Format	15-21
15-5	5:5:5:1 Format	15-21
15-6	MV Value for Each Display Mode.....	15-41
21-1	CODEC clock (CODECLK = 256 or 384fs).....	21-4
21-2	Usable Serial Bit Clock Frequency (IISCLK = 16 or 32 or 48fs).....	21-4
23-1	Camera Interface Signal Description.....	23-1
23-2	Video Timing Reference Codes of ITU-656 Format	23-4
27-1	Absolute Maximum Rating	27-1
27-2	Recommended Operating Conditions.....	27-2
27-3	Normal I/O PAD DC Electrical Characteristics.....	27-3
27-4	USB DC Electrical Characteristics	27-6
27-5	S3C2440 Power Supply Voltage and Current.....	27-6
27-6	Typical Current Decrease by CLKCON Register	27-7
27-7	Clock Timing Constants	27-35
27-8	ROM/SRAM Bus Timing Constants.....	27-36
27-9	Memory Interface Timing Constants	27-36
27-10	External Bus Request Timing Constants.....	27-37
27-11	DMA Controller Module Signal Timing Constants.....	27-37
27-12	TFT LCD Controller Module Signal Timing Constants	27-38
27-13	IIS Controller Module Signal Timing Constants	27-38
27-14	IIC BUS Controller Module Signal Timing	27-39
27-15	SD/MMC Interface Transmit/Receive Timing Constants	27-39
27-16	SPI Interface Transmit/Receive Timing Constants	27-40
27-17	USB Electrical Specifications	27-40
27-18	USB Full Speed Output Buffer Electrical Characteristics	27-41
27-19	USB Low Speed Output Buffer Electrical Characteristics.....	27-41
27-20	NAND Flash Interface Timing Constants	27-42

1 PRODUCT OVERVIEW

INTRODUCTION

This user's manual describes SAMSUNG's S3C2440A 16/32-bit RISC microprocessor. SAMSUNG's S3C2440A is designed to provide hand-held devices and general applications with low-power, and high-performance micro-controller solution in small die size. To reduce total system cost, the S3C2440A includes the following components.

The S3C2440A is developed with ARM920T core, 0.13um CMOS standard cells and a memory compier. Its low-power, simple, elegant and fully static design is particularly suitable for cost- and power-sensitive applications. It adopts a new bus architecture known as Advanced Micro controller Bus Architecture (AMBA).

The S3C2440A offers outstanding features with its CPU core, a 16/32-bit ARM920T RISC processor designed by Advanced RISC Machines, Ltd. The ARM920T implements MMU, AMBA BUS, and Harvard cache architecture with separate 16KB instruction and 16KB data caches, each with an 8-word line length.

By providing a complete set of common system peripherals, the S3C2440A minimizes overall system costs and eliminates the need to configure additional components. The integrated on-chip functions that are described in this document include:

- Around 1.2V internal, 1.8V/2.5V/3.3V memory, 3.3V external I/O microprocessor with 16KB I-Cache/16KB D-Cache/MMU
- External memory controller (SDRAM Control and Chip Select logic)
- LCD controller (up to 4K color STN and 256K color TFT) with LCD-dedicated DMA
- 4-ch DMA controllers with external request pins
- 3-ch UARTs (IrDA1.0, 64-Byte Tx FIFO, and 64-Byte Rx FIFO)
- 2-ch SPIs
- IIC bus interface (multi-master support)
- IIS Audio CODEC interface
- AC'97 CODEC interface
- SD Host interface version 1.0 & MMC Protocol version 2.11 compatible
- 2-ch USB Host controller / 1-ch USB Device controller (ver 1.1)
- 4-ch PWM timers / 1-ch Internal timer / Watch Dog Timer
- 8-ch 10-bit ADC and Touch screen interface
- RTC with calendar function
- Camera interface (Max. 4096 x 4096 pixels input support. 2048 x 2048 pixel input support for scaling)
- 130 General Purpose I/O ports / 24-ch external interrupt source
- Power control: Normal, Slow, Idle and Sleep mode
- On-chip clock generator with PLL

FEATURES

Architecture

- Integrated system for hand-held devices and general embedded applications.
- 16/32-Bit RISC architecture and powerful instruction set with ARM920T CPU core.
- Enhanced ARM architecture MMU to support WinCE, EPOC 32 and Linux.
- Instruction cache, data cache, write buffer and Physical address TAG RAM to reduce the effect of main memory bandwidth and latency on performance.
- ARM920T CPU core supports the ARM debug architecture.
- Internal Advanced Microcontroller Bus Architecture (AMBA) (AMBA2.0, AHB/APB).

System Manager

- Little/Big Endian support.
- Support Fast bus mode and Asynchronous bus mode.
- Address space: 128M bytes for each bank (total 1G bytes).
- Supports programmable 8/16/32-bit data bus width for each bank.
- Fixed bank start address from bank 0 to bank 6.
- Programmable bank start address and bank size for bank 7.
- Eight memory banks:
 - Six memory banks for ROM, SRAM, and others.
 - Two memory banks for ROM/SRAM/ Synchronous DRAM.
- Complete Programmable access cycles for all memory banks.
- Supports external wait signals to expand the bus cycle.
- Supports self-refresh mode in SDRAM for power-down.
- Supports various types of ROM for booting (NOR/NAND Flash, EEPROM, and others).

NAND Flash Boot Loader

- Supports booting from NAND flash memory.
- 4KB internal buffer for booting.
- Supports storage memory for NAND flash memory after booting.
- Supports Advanced NAND flash

Cache Memory

- 64-way set-associative cache with I-Cache (16KB) and D-Cache (16KB).
- 8words length per line with one valid bit and two dirty bits per line.
- Pseudo random or round robin replacement algorithm.
- Write-through or write-back cache operation to update the main memory.
- The write buffer can hold 16 words of data and four addresses.

Clock & Power Manager

- On-chip MPLL and UPLL:
 - UPLL generates the clock to operate USB Host/Device.
 - MPLL generates the clock to operate MCU at maximum 400Mhz @ 1.3V.
- Clock can be fed selectively to each function block by software.
- **Power mode:** Normal, Slow, Idle, and Sleep mode
 - Normal mode:** Normal operating mode
 - Slow mode:** Low frequency clock without PLL
 - Idle mode:** The clock for only CPU is stopped.
 - Sleep mode:** The Core power including all peripherals is shut down.
- Woken up by EINT[15:0] or RTC alarm interrupt from Sleep mode

FEATURES (Continued)

Interrupt Controller

- 60 Interrupt sources (One Watch dog timer, 5 timers, 9 UARTs, 24 external interrupts, 4 DMA, 2 RTC, 2 ADC, 1 IIC, 2 SPI, 1 SDI, 2 USB, 1 LCD, 1 Battery Fault, 1 NAND and 2 Camera), 1 AC97
- Level/Edge mode on external interrupt source
- Programmable polarity of edge and level
- Supports Fast Interrupt request (FIQ) for very urgent interrupt request

Timer with Pulse Width Modulation (PWM)

- 4-ch 16-bit Timer with PWM / 1-ch 16-bit internal timer with DMA-based or interrupt-based operation
- Programmable duty cycle, frequency, and polarity
- Dead-zone generation
- Supports external clock sources

RTC (Real Time Clock)

- Full clock feature: msec, second, minute, hour, date, day, month, and year
- 32.768 KHz operation
- Alarm interrupt
- Time tick interrupt

General Purpose Input/Output Ports

- 24 external interrupt ports
- 130 Multiplexed input/output ports

DMA Controller

- 4-ch DMA controller
- Supports memory to memory, IO to memory, memory to IO, and IO to IO transfers
- Burst transfer mode to enhance the transfer rate

LCD Controller STN LCD Displays Feature

- Supports 3 types of STN LCD panels: 4-bit dual scan, 4-bit single scan, 8-bit single scan display type

- Supports monochrome mode, 4 gray levels, 16 gray levels, 256 colors and 4096 colors for STN LCD
- Supports multiple screen size
 - Typical actual screen size: 640x480, 320x240, 160x160, and others.
 - Maximum frame buffer size is 4 Mbytes.
 - Maximum virtual screen size in 256 color mode: 4096x1024, 2048x2048, 1024x4096 and others

TFT(Thin Film Transistor) Color Displays Feature

- Supports 1, 2, 4 or 8 bpp (bit-per-pixel) palette color displays for color TFT
- Supports 16, 24 bpp non-palette true-color displays for color TFT
- Supports maximum 16M color TFT at 24 bpp mode
- LPC3600 Timing controller embedded for LTS350Q1-PD1/2(SAMSUNG 3.5" Portrait / 256K-color/ Reflective a-Si TFT LCD)
- LCC3600 Timing controller embedded for LTS350Q1-PE1/2(SAMSUNG 3.5" Portrait / 256K-color/ Transflective a-Si TFT LCD)
- Supports multiple screen size
 - Typical actual screen size: 640x480, 320x240, 160x160, and others.
 - Maximum frame buffer size is 4Mbytes.
 - Maximum virtual screen size in 64K color mode: 2048x1024, and others

UART

- 3-channel UART with DMA-based or interrupt-based operation
- Supports 5-bit, 6-bit, 7-bit, or 8-bit serial data transmit/receive (Tx/Rx)
- Supports external clocks for the UART operation (UEXTCLK)
- Programmable baud rate
- Supports IrDA 1.0
- Loopback mode for testing
- Each channel has internal 64-byte Tx FIFO and 64-byte Rx FIFO.

FEATURES (Continued)

A/D Converter & Touch Screen Interface

- 8-ch multiplexed ADC
- Max. 500KSPS and 10-bit Resolution
- Internal FET for direct Touch screen interface

Watchdog Timer

- 16-bit Watchdog Timer
- Interrupt request or system reset at time-out

IIC-Bus Interface

- 1-ch Multi-Master IIC-Bus
- Serial, 8-bit oriented and bi-directional data transfers can be made at up to 100 Kbit/s in Standard mode or up to 400 Kbit/s in Fast mode.

IIS-Bus Interface

- 1-ch IIS-bus for audio interface with DMA-based operation
- Serial, 8-/16-bit per channel data transfers
- 128 Bytes (64-Byte + 64-Byte) FIFO for Tx/Rx
- Supports IIS format and MSB-justified data format

AC97 Audio-CODEC Interface

- Support 16-bit samples
- 1-ch stereo PCM inputs/ 1-ch stereo PCM outputs

1-ch MIC input

USB Host

- 2-port USB Host
- Complies with OHCI Rev. 1.0
- Compatible with USB Specification version 1.1

USB Device

- 1-port USB Device
- 5 Endpoints for USB Device
- Compatible with USB Specification version 1.1

SD Host Interface

- Normal, Interrupt and DMA data transfer mode (byte, halfword, word transfer)

- DMA burst4 access support (only word transfer)
- Compatible with SD Memory Card Protocol version 1.0
- Compatible with SDIO Card Protocol version 1.0
- 64 Bytes FIFO for Tx/Rx
- Compatible with Multimedia Card Protocol version 2.11

SPI Interface

- Compatible with 2-ch Serial Peripheral Interface Protocol version 2.11
- 2x8 bits Shift register for Tx/Rx
- DMA-based or interrupt-based operation

Camera Interface

- ITU-R BT 601/656 8-bit mode support
- DZI (Digital Zoom In) capability
- Programmable polarity of video sync signals
- Max. 4096 x 4096 pixels input support (2048 x 2048 pixel input support for scaling)
- Image mirror and rotation (X-axis mirror, Y-axis mirror, and 180° rotation)
- Camera output format (RGB 16/24-bit and YCbCr 4:2:0/4:2:2 format)

Operating Voltage Range

- Core: 1.20V for 300MHz
1.30V for 400MHz
- Memory: 1.8V/ 2.5V/3.0V/3.3V
- I/O: 3.3V

Operating Frequency

- Fclk Up to 400MHz
- Hclk Up to 136MHz
- Pclk Up to 68MHz

Package

- 289-FBGA

BLOCK DIAGRAM

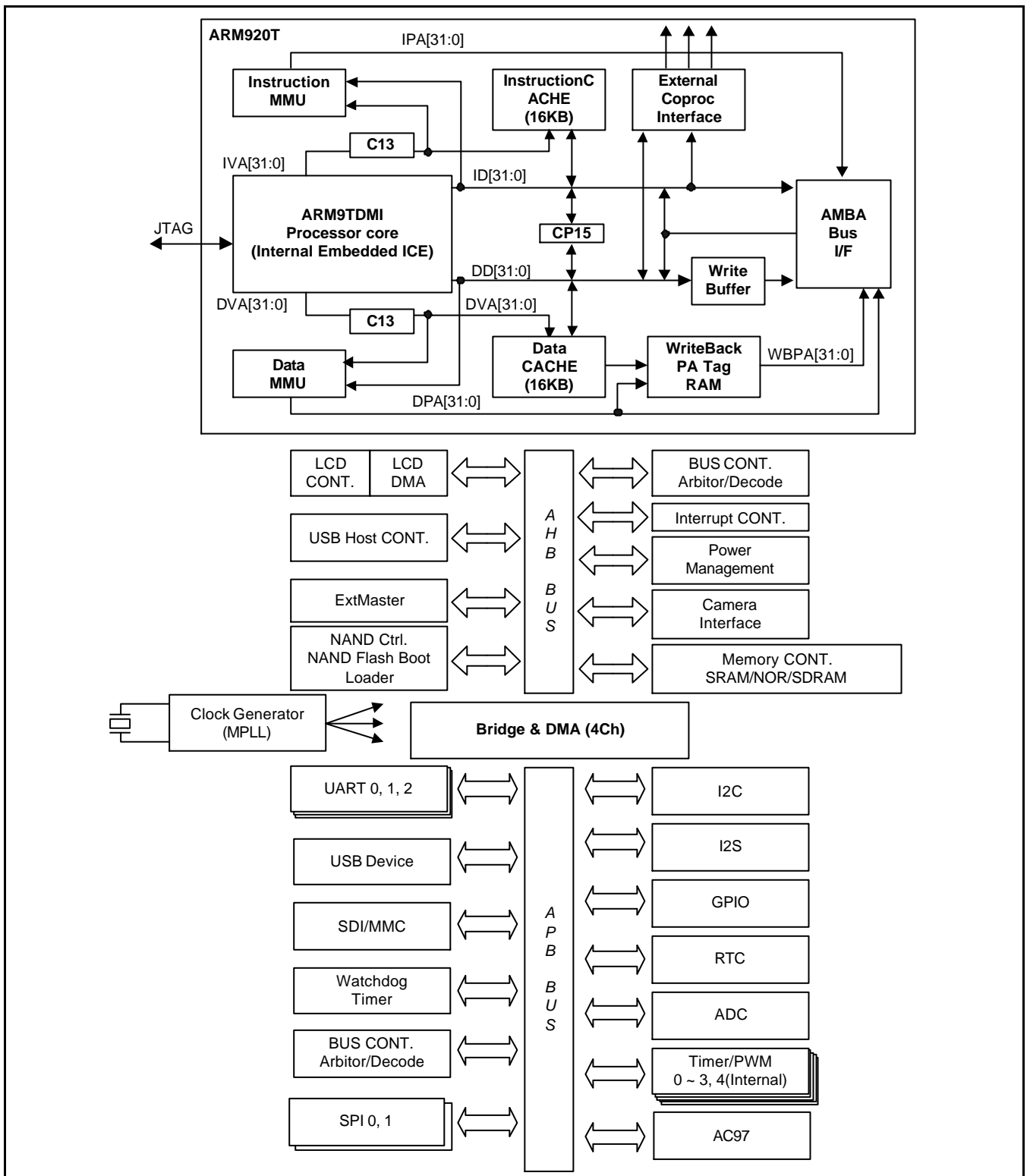

Figure 1-1. S3C2440A Block Diagram

PIN ASSIGNMENTS

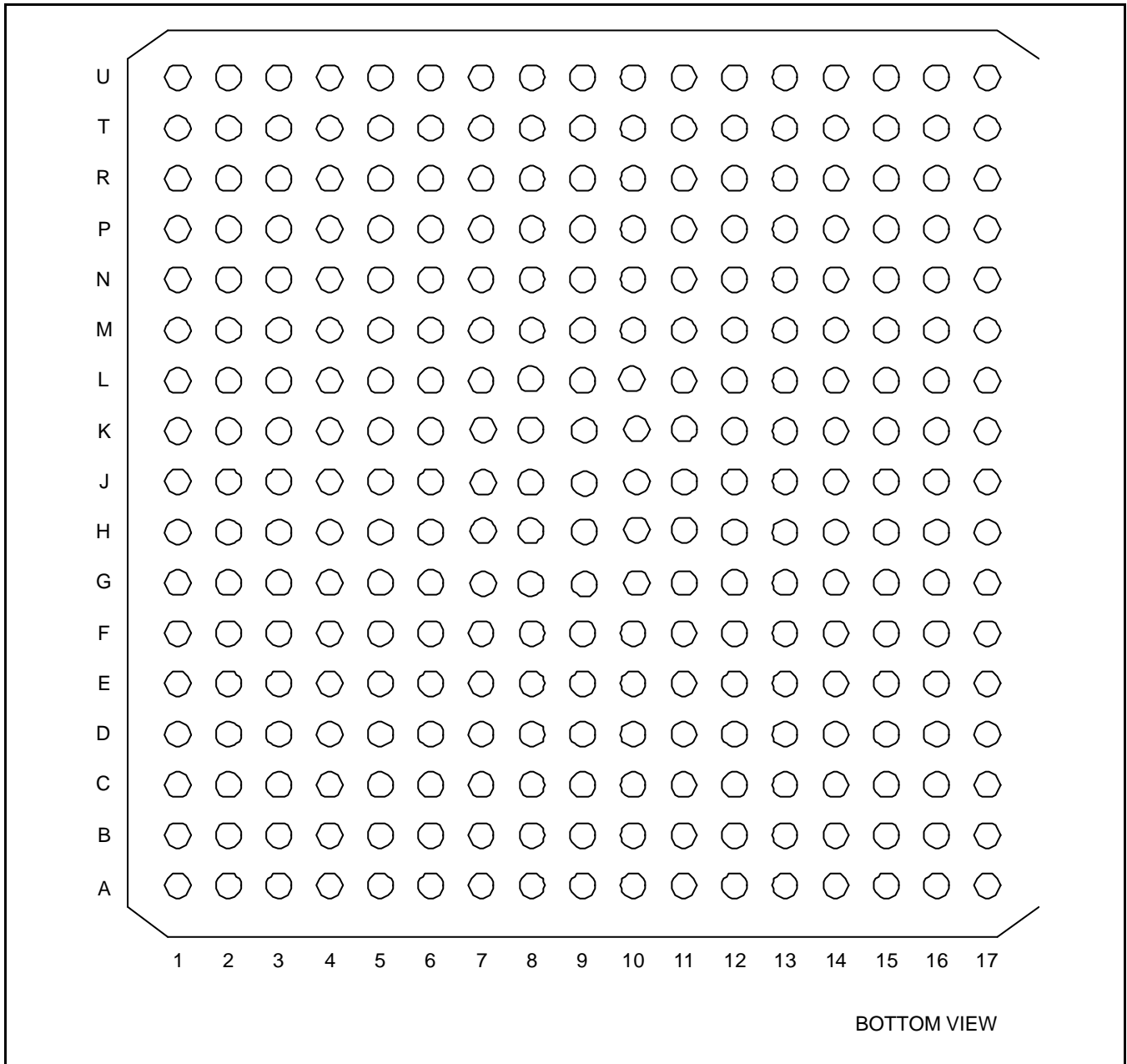

Figure 1-2. S3C2440A Pin Assignments (289-FBGA)

Table 1-1. 289-Pin FBGA Pin Assignments – Pin Number Order (Sheet 1 of 3)

Pin Number	Pin Name	Pin Number	Pin Name	Pin Number	Pin Name
A1	VDDi	C1	VDDMOP	E1	nFRE/GPA20
A2	SCKE	C2	nGCS5/GPA16	E2	VSSMOP
A3	VSSi	C3	nGCS2/GPA13	E3	nGCS7
A4	VSSi	C4	nGCS3/GPA14	E4	nWAIT
A5	VSSMOP	C5	nOE	E5	nBE3
A6	VDDi	C6	nSRAS	E6	nWE
A7	VSSMOP	C7	ADDR4	E7	ADDR1
A8	ADDR10	C8	ADDR11	E8	ADDR6
A9	VDDMOP	C9	ADDR15	E9	ADDR14
A10	VDDi	C10	ADDR21/GPA6	E10	ADDR23/GPA8
A11	VSSMOP	C11	ADDR24/GPA9	E11	DATA2
A12	VSSi	C12	DATA1	E12	DATA20
A13	DATA3	C13	DATA6	E13	DATA19
A14	DATA7	C14	DATA11	E14	DATA18
A15	VSSMOP	C15	DATA13	E15	DATA17
A16	VDDi	C16	DATA16	E16	DATA21
A17	DATA10	C17	VSSi	E17	DATA24
B1	VSSMOP	D1	ALE/GPA18	F1	VDDi
B2	nGCS1/GPA12	D2	nGCS6	F2	VSSi
B3	SCLK1	D3	nGCS4/GPA15	F3	nFWE/GPA19
B4	SCLK0	D4	nBE0	F4	nFCE/GPA22
B5	nBE1	D5	nBE2	F5	CLE/GPA17
B6	VDDMOP	D6	nSCAS	F6	nGCS0
B7	ADDR2	D7	ADDR7	F7	ADDR0/GPA0
B8	ADDR9	D8	ADDR5	F8	ADDR3
B9	ADDR12	D9	ADDR16/GPA1	F9	ADDR18/GPA3
B10	VSSi	D10	ADDR20/GPA5	F10	DATA4
B11	VDDi	D11	ADDR26/GPA11	F11	DATA5
B12	VDDMOP	D12	DATA0	F12	DATA27
B13	VSSMOP	D13	DATA8	F13	DATA31
B14	VDDMOP	D14	DATA14	F14	DATA26
B15	DATA9	D15	DATA12	F15	DATA22
B16	VDDMOP	D16	VSSMOP	F16	VDDi
B17	DATA15	D17	VSSMOP	F17	VDDMOP

Table 1-1. 289-Pin FBGA Pin Assignments – Pin Number Order (Sheet 2 of 3) (Continued)

Pin Number	Pin Name	Pin Number	Pin Name	Pin Number	Pin Name
G1	VSSOP	J1	VDDOP	L1	LEND/GPC0
G2	CAMHREF/GPJ10	J2	VDDiarm	L2	VDDiarm
G3	CAMDATA1/GPJ1	J3	CAMCLKOUT/GPJ11	L3	nXDACK0/GPB9
G4	VDDalive	J4	CAMRESET/GPJ12	L4	VCLK/GPC1
G5	CAMPCLK/GPJ8	J5	TOUT1/GPB1	L5	nXBREQ/GPB6
G6	FRnB	J6	TOUT0/GPB0	L6	VD1/GPC9
G7	CAMVSYNC/GPJ9	J7	TOUT2/GPB2	L7	VFRAME/GPC3
G8	ADDR8	J8	CAMDATA6/GPJ6	L8	I2SSDI/AC_SDATA_IN
G9	ADDR17/GPA2	J9	SDDAT3/GPE10	L9	SPICLK0/GPE13
G10	ADDR25/GPA10	J10	EINT10/nSS0/GPG2	L10	EINT15/SPICLK1/GPG7
G11	DATA28	J11	TXD2/nRTS1/GPH6	L11	EINT22/GPG14
G12	DATA25	J12	PWREN	L12	Xtortc
G13	DATA23	J13	TCK	L13	EINT2/GPF2
G14	XTIpll	J14	TMS	L14	EINT5/GPF5
G15	XTOpll	J15	RXD2/nCTS1/GPH7	L15	EINT6/GPF6
G16	DATA29	J16	TDO	L16	EINT7/GPF7
G17	VSSi	J17	VDDalive	L17	nRTS0/GPH1
H1	VSSiarm	K1	VSSiarm	M1	VLINE/GPC2
H2	CAMDATA7/GPJ7	K2	nXBACK/GPB5	M2	LCD_LPCREV/GPC6
H3	CAMDATA4/GPJ4	K3	TOUT3/GPB3	M3	LCD_LPCOE/GPC5
H4	CAMDATA3/GPJ3	K4	TCLK0/GPB4	M4	VM/GPC4
H5	CAMDATA2/GPJ2	K5	nXDREQ1/GPB8	M5	VD9/GPD1
H6	CAMDATA0/GPJ0	K6	nXDREQ0/GPB10	M6	VD6/GPC14
H7	CAMDATA5/GPJ5	K7	nXDACK1/GPB7	M7	VD16/SPIMISO1/GPD8
H8	ADDR13	K8	SDCMD/GPE6	M8	SDDAT1/GPE8
H9	ADDR19/GPA4	K9	SPIMISO0/GPE11	M9	IICSDA/GPE15
H10	ADDR22/GPA7	K10	EINT13/SPIMISO1/GPG5	M10	EINT20/GPG12
H11	VSSOP	K11	nCTS0/GPH0	M11	EINT17/nRTS1/GPG9
H12	EXTCLK	K12	VDDOP	M12	VSSA_UPLL
H13	DATA30	K13	TXD0/GPH2	M13	VDDA_UPLL
H14	nBATT_FLT	K14	RXD0/GPH3	M14	Xtirtc
H15	nTRST	K15	UEXTCLK/GPH8	M15	EINT3/GPF3
H16	nRESET	K16	TXD1/GPH4	M16	EINT1/GPF1
H17	TDI	K17	RXD1/GPH5	M17	EINT4/GPF4

Table 1-1. 289-Pin FBGA Pin Assignments – Pin Number Order (Sheet 3 of 3) (Continued)

Pin Number	Pin Name	Pin Number	Pin Name	Pin Number	Pin Name
N1	VSSOP	P15	AIN3	T12	VDDOP
N2	VD0/GPC8	P16	XP/AIN7	T13	OM3
N3	VD4/GPC12	P17	UPLLCAP	T14	VSSA_ADC
N4	VD2/GPC10	R1	VD3/GPC11	T15	OM0
N5	VD10/GPD2	R2	VD8/GPD0	T16	YM/AIN4
N6	VD15/GPD7	R3	VD11/GPD3	T17	YP/AIN5
N7	VD22/nSS1/GPD14	R4	VD13/GPD5	U1	VDDiarm
N8	SDCLK/GPE5	R5	VD18/SPICLK1/GPD10	U2	VDDiarm
N9	EINT8/GPG0	R6	VD21 /GPD13	U3	VSSOP
N10	EINT18/nCTS1/GPG10	R7	I2SSCLK/AC_BIT_CLK	U4	VSSiarm
N11	DP0	R8	SDDAT0/GPE7	U5	VD23/nSS0/GPD15
N12	DN1/PDN0	R9	CLKOUT0/GPH9	U6	I2SSDO/AC_SDATA_OUT
N13	nRSTOUT/GPA21	R10	EINT11/nSS1/GPG3	U7	VSSiarm
N14	MPLLCAP	R11	EINT14/SPIMOSI1/GPG6	U8	IIC_SCL/GPE14
N15	VDD_RTC	R12	NCON	U9	VSSOP
N16	VDDA_MPLL	R13	OM1	U10	VSSiarm
N17	EINT0/GPF0	R14	AIN0	U11	VDDi
P1	LCD_LPCREVB/GPC7	R15	AIN2	U12	EINT19/TCLK1/GPG11
P2	VD5/GPC13	R16	XM/AIN6	U13	EINT23/GPG15
P3	VD7/GPC15	R17	VSSA_MPLL	U14	DP1/PDP0
P4	VD12/GPD4	T1	VSSiarm	U15	VSSOP
P5	VD14/GPD6	T2	VSSiarm	U16	Vref
P6	VD20/GPD12	T3	VDDOP	U17	AIN1
P7	I2SLRCK/AC_SYNC	T4	VD17/SPIMOSI1/GPD9		
P8	SDDAT2/GPE9	T5	VD19/GPD11		
P9	SPIMOSI0/GPE12	T6	VDDiarm		
P10	CLKOUT1/GPH10	T7	CDCLK/AC_nRESET		
P11	EINT12/LCD_PWREN/ GPG4	T8	VDDiarm		
P12	DN0	T9	EINT9/GPG1		
P13	OM2	T10	EINT16/GPG8		
P14	VDDA_ADC	T11	EINT21/GPG13		

Table 1-2. S3C2440A 289-Pin FBGA Pin Assignments (Sheet 1 of 9)

Pin Number	Pin Name	Default Function	I/O State @BUS REQ	I/O State @Sleep	I/O State @nRESET	I/O Type
F7	ADDR0/GPA0	ADDR0	Hi-z/-	O(L)/-	O(L)	t10s
E7	ADDR1	ADDR1	Hi-z	O(L)	O(L)	t10s
B7	ADDR2	ADDR2	Hi-z	O(L)	O(L)	t10s
F8	ADDR3	ADDR3	Hi-z	O(L)	O(L)	t10s
C7	ADDR4	ADDR4	Hi-z	O(L)	O(L)	t10s
D8	ADDR5	ADDR5	Hi-z	O(L)	O(L)	t10s
E8	ADDR6	ADDR6	Hi-z	O(L)	O(L)	t10s
D7	ADDR7	ADDR7	Hi-z	O(L)	O(L)	t10s
G8	ADDR8	ADDR8	Hi-z	O(L)	O(L)	t10s
B8	ADDR9	ADDR9	Hi-z	O(L)	O(L)	t10s
A8	ADDR10	ADDR10	Hi-z	O(L)	O(L)	t10s
C8	ADDR11	ADDR11	Hi-z	O(L)	O(L)	t10s
B9	ADDR12	ADDR12	Hi-z	O(L)	O(L)	t10s
H8	ADDR13	ADDR13	Hi-z	O(L)	O(L)	t10s
E9	ADDR14	ADDR14	Hi-z	O(L)	O(L)	t10s
C9	ADDR15	ADDR15	Hi-z	O(L)	O(L)	t10s
D9	ADDR16/GPA1	ADDR16	Hi-z/-	O(L)/-	O(L)	t10s
G9	ADDR17/GPA2	ADDR17	Hi-z/-	O(L)/-	O(L)	t10s
F9	ADDR18/GPA3	ADDR18	Hi-z/-	O(L)/-	O(L)	t10s
H9	ADDR19/GPA4	ADDR19	Hi-z/-	O(L)/-	O(L)	t10s
D10	ADDR20/GPA5	ADDR20	Hi-z/-	O(L)/-	O(L)	t10s
C10	ADDR21/GPA6	ADDR21	Hi-z/-	O(L)/-	O(L)	t10s
H10	ADDR22/GPA7	ADDR22	Hi-z/-	O(L)/-	O(L)	t10s
E10	ADDR23/GPA8	ADDR23	Hi-z/-	O(L)/-	O(L)	t10s
C11	ADDR24/GPA9	ADDR24	Hi-z/-	O(L)/-	O(L)	t10s
G10	ADDR25/GPA10	ADDR25	Hi-z/-	O(L)/-	O(L)	t10s
D11	ADDR26/GPA11	ADDR26	Hi-z/-	O(L)/-	O(L)	t10s
R14	AIN0	AIN0	-	-	AI	r10
U17	AIN1	AIN1	-	-	AI	r10
R15	AIN2	AIN2	-	-	AI	r10
P15	AIN3	AIN3	-	-	AI	r10
T16	YM/AIN4	AIN4	-/-	-/-	AI	r10
T17	YP/AIN5	YP	-/-	-/-	AI	r10
R16	XM/AIN6	AIN6	-/-	-/-	AI	r10

Table 1-2. S3C2440A 289-Pin FBGA Pin Assignments (Sheet 2 of 9) (Continued)

Pin Number	Pin Name	Default Function	I/O State @BUS REQ	I/O State @Sleep	I/O State @nRESET	I/O Type
P16	XP/AIN7	XP	-/-	-/-	AI	r10
H6	CAMDATA0/GPJ0	GPJ0	-/-	Hi-z/-	I	t8
G3	CAMDATA1/GPJ1	GPJ1	-/-	Hi-z/-	I	t8
H5	CAMDATA2/GPJ2	GPJ2	-/-	Hi-z/-	I	t8
H4	CAMDATA3/GPJ3	GPJ3	-/-	Hi-z/-	I	t8
H3	CAMDATA4/GPJ4	GPJ4	-/-	Hi-z/-	I	t8
H7	CAMDATA5/GPJ5	GPJ5	-/-	Hi-z/-	I	t8
J8	CAMDATA6/GPJ6	GPJ6	-/-	Hi-z/-	I	t8
H2	CAMDATA7/GPJ7	GPJ7	-/-	Hi-z/-	I	t8
G5	CAMPCLK/GPJ8	GPJ8	-/-	Hi-z/-	I	t8
G7	CAMVSYNC/GPJ9	GPJ9	-/-	Hi-z/-	I	t8
G2	CAMHREF/GPJ10	GPJ10	-/-	Hi-z/-	I	t8
J3	CAMCLKOUT/GPJ11	GPJ11	-/-	O(L)/-	I	t8
J4	CAMRESET/GPJ12	GPJ12	-/-	O(L)/-	I	t8
D12	DATA0	DATA0	Hi-z	Hi-z,O(L)	I	b12s
C12	DATA1	DATA1	Hi-z	Hi-z,O(L)	I	b12s
E11	DATA2	DATA2	Hi-z	Hi-z,O(L)	I	b12s
A13	DATA3	DATA3	Hi-z	Hi-z,O(L)	I	b12s
F10	DATA4	DATA4	Hi-z	Hi-z,O(L)	I	b12s
F11	DATA5	DATA5	Hi-z	Hi-z,O(L)	I	b12s
C13	DATA6	DATA6	Hi-z	Hi-z,O(L)	I	b12s
A14	DATA7	DATA7	Hi-z	Hi-z,O(L)	I	b12s
D13	DATA8	DATA8	Hi-z	Hi-z,O(L)	I	b12s
B15	DATA9	DATA9	Hi-z	Hi-z,O(L)	I	b12s
A17	DATA10	DATA10	Hi-z	Hi-z,O(L)	I	b12s
C14	DATA11	DATA11	Hi-z	Hi-z,O(L)	I	b12s
D15	DATA12	DATA12	Hi-z	Hi-z,O(L)	I	b12s
C15	DATA13	DATA13	Hi-z	Hi-z,O(L)	I	b12s
D14	DATA14	DATA14	Hi-z	Hi-z,O(L)	I	b12s
B17	DATA15	DATA15	Hi-z	Hi-z,O(L)	I	b12s
C16	DATA16	DATA16	Hi-z	Hi-z,O(L)	I	b12s
E15	DATA17	DATA17	Hi-z	Hi-z,O(L)	I	b12s
E14	DATA18	DATA18	Hi-z	Hi-z,O(L)	I	b12s

Table 1-2. S3C2440A 289-Pin FBGA Pin Assignments (Sheet 3 of 9) (Continued)

Pin Number	Pin Name	Default Function	I/O State @BUS REQ	I/O State @Sleep	I/O State @nRESET	I/O Type
E13	DATA19	DATA19	Hi-z	Hi-z,O(L)	I	b12s
E12	DATA20	DATA20	Hi-z	Hi-z,O(L)	I	b12s
E16	DATA21	DATA21	Hi-z	Hi-z,O(L)	I	b12s
F15	DATA22	DATA22	Hi-z	Hi-z,O(L)	I	b12s
G13	DATA23	DATA23	Hi-z	Hi-z,O(L)	I	b12s
E17	DATA24	DATA24	Hi-z	Hi-z,O(L)	I	b12s
G12	DATA25	DATA25	Hi-z	Hi-z,O(L)	I	b12s
F14	DATA26	DATA26	Hi-z	Hi-z,O(L)	I	b12s
F12	DATA27	DATA27	Hi-z	Hi-z,O(L)	I	b12s
G11	DATA28	DATA28	Hi-z	Hi-z,O(L)	I	b12s
G16	DATA29	DATA29	Hi-z	Hi-z,O(L)	I	b12s
H13	DATA30	DATA30	Hi-z	Hi-z,O(L)	I	b12s
F13	DATA31	DATA31	Hi-z	Hi-z,O(L)	I	b12s
P12	DN0	DN0	-	-	AI	us
N11	DP0	DP0	-	-	AI	us
N12	DN1/PDN0	DN1	-/-	-	AI	us
U14	DP1/PDP0	DP1	-/-	-	AI	us
N17	EINT0/GPF0	GPF0	-/-	Hi-z/-	I	t8
M16	EINT1/GPF1	GPF1	-/-	Hi-z/-	I	t8
L13	EINT2/GPF2	GPF2	-/-	Hi-z/-	I	t8
M15	EINT3/GPF3	GPF3	-/-	Hi-z/-	I	t8
M17	EINT4/GPF4	GPF4	-/-	Hi-z/-	I	t8
L14	EINT5/GPF5	GPF5	-/-	Hi-z/-	I	t8
L15	EINT6/GPF6	GPF6	-/-	Hi-z/-	I	t8
L16	EINT7/GPF7	GPF7	-/-	Hi-z/-	I	t8
N9	EINT8/GPG0	GPG0	-/-	Hi-z/-	I	t8
T9	EINT9/GPG1	GPG1	-/-	Hi-z/-	I	t8
J10	EINT10/nSS0/GPG2	GPG2	-/-/-	Hi-z/Hi-z/-	I	t8
R10	EINT11/nSS1/GPG3	GPG3	-/-/-	Hi-z/Hi-z/-	I	t8
P11	EINT12/LCD_PWREN/GPG4	GPG4	-/-/-	Hi-z/O(L)/-	I	t8
K10	EINT13/SPIMISO1/GPG5	GPG5	-/-/-	Hi-z/Hi-z/-	I	t8
R11	EINT14/SPIMOSI1/GPG6	GPG6	-/-/-	Hi-z/Hi-z/-	I	t8
L10	EINT15/SPICLK1/GPG7	GPG7	-/-/-	Hi-z/Hi-z/-	I	t8

Table 1-2. S3C2440A 289-Pin FBGA Pin Assignments (Sheet 4 of 9) (Continued)

Pin Number	Pin Name	Default Function	I/O State @BUS REQ	I/O State @Sleep	I/O State @nRESET	I/O Type
T10	EINT16/GPG8	GPG8	-/-	Hi-z/-	I	t8
M11	EINT17/nRTS1/GPG9	GPG9	-/-/-	Hi-z/O(H)/-	I	t8
N10	EINT18/nCTS1/GPG10	GPG10	-/-/-	Hi-z/Hi-z/-	I	t8
U12	EINT19/TCLK1/GPG11	GPG11	-/-/-	Hi-z/Hi-z/-	I	t12
M10	EINT20/GPG12	GPG12	-/-	Hi-z/-	I	t12
T11	EINT21/GPG13	GPG13	-/-	Hi-z/-	I	t12
L11	EINT22/GPG14	GPG14	-/-	Hi-z/-	I	t12
U13	EINT23/GPG15	GPG15	-/-	Hi-z/-	I	t12
H12	EXTCLK	EXTCLK	-	-	AI	is
P17	UPLLCAP	UPLLCAP	-	-	AI	r50
N14	MPLLCAP	MPLLCAP	-	-	AI	r50
H14	nBATT_FLT	nBATT_FLT	-	-	I	is
D4	nBE0	nBE0	Hi-z	Hi-z,O(H)	O(H)	t10s
B5	nBE1	nBE1	Hi-z	Hi-z,O(H)	O(H)	t10s
D5	nBE2	nBE2	Hi-z	Hi-z,O(H)	O(H)	t10s
E5	nBE3	nBE3	Hi-z	Hi-z,O(H)	O(H)	t10s
R12	NCON	NCON	-	-	I	is
G6	FRnB	FRnB	-	Hi-z,O(L)	I	d2s
F3	nFRE/GPA19	GPA19	O(H)/-	Hi-z,O(H)/-	O(H)	t10s
E1	nFRE/GPA20	GPA20	O(H)/-	Hi-z,O(H)/-	O(H)	t10s
F4	nFCE/GPA22	GPA21	O(H)/-	Hi-z,O(H)/-	O(H)	t10s
F5	CLE/GPA17	GPA17	O(L)/-	Hi-z,O(L)/-	O(L)	t10s
D1	ALE/GPA18	GPA18	O(L)/-	Hi-z,O(L)/-	O(L)	t10s
N13	nRSTOUT/GPA21	GPA21	-/-	O(L)/-	O(L)	b8
C5	nOE	nOE	Hi-z	Hi-z,O(H)	O(H)	t10s
H16	nRESET	nRESET	-	-	I	is
F6	nGCS0	nGCS0	Hi-z	Hi-z,O(H)	O(H)	t10s
B2	nGCS1/GPA12	GPA12	Hi-z/-	Hi-z,O(H)/-	O(H)	t10s
C3	nGCS2/GPA13	GPA13	Hi-z/-	Hi-z,O(H)/-	O(H)	t10s
C4	nGCS3/GPA14	GPA14	Hi-z/-	Hi-z,O(H)/-	O(H)	t10s
D3	nGCS4/GPA15	GPA15	Hi-z/-	Hi-z,O(H)/-	O(H)	t10s
C2	nGCS5/GPA16	GPA16	Hi-z/-	Hi-z,O(H)/-	O(H)	t10s
D2	nGCS6	nGCS6	Hi-z	Hi-z,O(H)	O(H)	t10s

Table 1-2. S3C2440A 289-Pin FBGA Pin Assignments (Sheet 5 of 9) (Continued)

Pin Number	Pin Name	Default Function	I/O State @BUS REQ	I/O State @Sleep	I/O State @nRESET	I/O Type
E3	nGCS7	nGCS7	Hi-z	Hi-z,O(H)	O(H)	t10s
D6	nSCAS	nSCAS	Hi-z	Hi-z,O(H)	O(H)	t10s
C6	nSRAS	nSRAS	Hi-z	Hi-z,O(H)	O(H)	t10s
H15	nTRST	nTRST	I	-	I	is
E4	nWAIT	nWAIT	-	Hi-z,O(L)	I	d2s
E6	nWE	nWE	Hi-z	Hi-z,O(H)	O(H)	t10s
J6	TOUT0/GPB0	GPB0	-/-	O(L)/-	I	t8
J5	TOUT1/GPB1	GPB1	-/-	O(L)/-	I	t8
J7	TOUT2/GPB2	GPB2	-/-	O(L)/-	I	t8
K3	TOUT3/GPB3	GPB3	-/-	O(L)/-	I	t8
K4	TCLK0/GPB4	GPB4	-/-	-/-	I	t8
K2	nXBACK/GPB5	GPB5	-/-	O(H)/-	I	t8
L5	nXBREQ/GPB6	GPB6	-/-	-/-	I	t8
K7	nXDACK1/GPB7	GPB7	-/-	O(H)/-	I	t8
K5	nXDREQ1/GPB8	GPB8	-/-	-/-	I	t8
L3	nXDACK0/GPB9	GPB9	-/-	O(H)/-	I	t8
K6	nXDREQ0/GPB10	GPB10	-/-	-/-	I	t8
T15	OM0	OM0	-	-	I	is
R13	OM1	OM1	-	-	I	is
P13	OM2	OM2	-	-	I	is
T13	OM3	OM3	-	-	I	is
J12	PWREN	PWREN	O(H)	O(L)	O(H)	b8
K11	nCTS0/GPH0	GPH0	-/-	-/-	I	t8
L17	nRTS0/GPH1	GPH1	-/-	O(H)/-	I	t8
K13	TXD0/GPH2	GPH2	-/-	O(H)/-	I	t8
K14	RXD0/GPH3	GPH3	-/-	-/-	I	t8
K16	TXD1/GPH4	GPH4	-/-	O(H)/-	I	t8
K17	RXD1/GPH5	GPH5	-/-	-/-	I	t8
J11	TXD2/nRTS1/GPH6	GPH6	-/-/-	O(H)/O(H)/-	I	t8
J15	RXD2/nCTS1/GPH7	GPH7	-/-/-	Hi-z/Hi-z/-	I	t8
K15	UEXTCLK/GPH8	GPH8	-/-	Hi-z/-	I	t8
R9	CLKOUT0/GPH9	GPH9	-/-	O(L)/-	I	t12
P10	CLKOUT1/GPH10	GPH10	-/-	O(L)/-	I	t12

Table 1-2. S3C2440A 289-Pin FBGA Pin Assignments (Sheet 6 of 9) (Continued)

Pin Number	Pin Name	Default Function	I/O State @BUS REQ	I/O State @Sleep	I/O State @nRESET	I/O Type
A2	SCKE	SCKE	Hi-z	O(L)	O(H)	t10s
B4	SCLK0	SCLK0	Hi-z	O(L)	O(SCLK)	t12s
B3	SCLK1	SCLK1	Hi-z	O(L)	O(SCLK)	t12s
P7	I2SLRCK/AC_SYNC	GPE0	-/-	Hi-z/-	I	t8
R7	I2SSCLK/AC_BIT_CLK	GPE1	-/-	Hi-z/-	I	t8
T7	CDCLK/AC_nRESET	GPE2	-/-	Hi-z/-	I	t8
L8	I2SSDI/AC_SDATA_IN	GPE3	-/-/-	Hi-z/Hi-z/-	I	t8
U6	I2SSDO/AC_SDATA_OUT	GPE4	-/-/-	O(L)/Hi-z/-	I	t8
N8	SDCLK/GPE5	GPE5	-/-	O(L)/-	I	t8
K8	SDCMD/GPE6	GPE6	-/-	Hi-z/-	I	t8
R8	SDDAT0/GPE7	GPE7	-/-	Hi-z/-	I	t8
M8	SDDAT1/GPE8	GPE8	-/-	Hi-z/-	I	t8
P8	SDDAT2/GPE9	GPE9	-/-	Hi-z/-	I	t8
J9	SDDAT3/GPE10	GPE10	-/-	Hi-z/-	I	t8
K9	SPIMISO0/GPE11	GPE11	-/-	Hi-z/-	I	t8
P9	SPIMOSI0/GPE12	GPE12	-/-	Hi-z/-	I	t8
L9	SPICLK0/GPE13	GPE13	-/-	Hi-z/-	I	t8
U8	IIC SCL/GPE14	GPE14	-/-	Hi-z/-	I	d8
M9	IIC SDA/GPE15	GPE15	-/-	Hi-z/-	I	d8
J13	TCK	TCK	I	-	I	is
H17	TDI	TDI	I	-	I	is
J16	TDO	TDO	O	O	O	ot
J14	TMS	TMS	I	-	I	is
L1	LEND/GPC0	GPC0	-/-	O(L)/-	I	t8
L4	VCLK/GPC1	GPC1	-/-	O(L)/-	I	t8
M1	VLINE/GPC2	GPC2	-/-	O(L)/-	I	t8
L7	VFRAME/GPC3	GPC3	-/-	O(L)/-	I	t8
M4	VM/GPC4	GPC4	-/-	O(L)/-	I	t8
M3	LCD_LPCOE/GPC5	GPC5	-/-	O(L)/-	I	t8
M2	LCD_LPCREV/GPC6	GPC6	-/-	O(L)/-	I	t8
P1	LCD_LPCREVB/GPC7	GPC7	-/-	O(L)/-	I	t8
N2	VD0/GPC8	GPC8	-/-	O(L)/-	I	t8
L6	VD1/GPC9	GPC9	-/-	O(L)/-	I	t8

Table 1-2. S3C2440A 289-Pin FBGA Pin Assignments (Sheet 7 of 9) (Continued)

Pin Number	Pin Name	Default Function	I/O State @BUS REQ	I/O State @Sleep	I/O State @nRESET	I/O Type
N4	VD2/GPC10	GPC10	-/-	O(L)/-	I	t8
R1	VD3/GPC11	GPC11	-/-	O(L)/-	I	t8
N3	VD4/GPC12	GPC12	-/-	O(L)/-	I	t8
P2	VD5/GPC13	GPC13	-/-	O(L)/-	I	t8
M6	VD6/GPC14	GPC14	-/-	O(L)/-	I	t8
P3	VD7/GPC15	GPC15	-/-	O(L)/-	I	t8
R2	VD8/GPD0	GPD0	-/-	O(L)/-	I	t8
M5	VD9/GPD1	GPD1	-/-	O(L)/-	I	t8
N5	VD10/GPD2	GPD2	-/-	O(L)/-	I	t8
R3	VD11/GPD3	GPD3	-/-	O(L)/-	I	t8
P4	VD12/GPD4	GPD4	-/-	O(L)/-	I	t8
R4	VD13/ GPD5	GPD5	-/-/-	O(L)/O/-	I	t8
P5	VD14/GPD6	GPD6	-/-/-	O(L)/O/-	I	t8
N6	VD15/GPD7	GPD7	-/-/-	O(L)/O/-	I	t8
M7	VD16/SPIMISO1/GPD8	GPD8	-/-/-	O(L)/Hi-z/-	I	t8
T4	VD17/SPIMOSI1/GPD9	GPD9	-/-/-	O(L)/Hi-z/-	I	t8
R5	VD18/SPICLK1/GPD10	GPD10	-/-/-	O(L)/Hi-z/-	I	t8
T5	VD19//GPD11	GPD11	-/-/-	O(L)/Hi-z/-	I	t8
P6	VD20/ GPD12	GPD12	-/-/-	O(L)/Hi-z/-	I	t8
R6	VD21/ GPD13	GPD13	-/-/-	O(L)/Hi-z/-	I	t8
N7	VD22/nSS1/GPD14	GPD14	-/-/-	O(L)/Hi-z/-	I	t8
U5	VD23/nSS0/GPD15	GPD15	-/-/-	O(L)/Hi-z/-	I	t8
U16	Vref	Vref	-	-	AI	ia
G14	XTIpll	XTIpll	-	-	AI	m26
M14	Xtirtc	Xtirtc	-	-	AI	nc
G15	XTOpll	XTOpll	-	-	AO	m26
L12	Xtortc	Xtortc	-	-	AO	nc
N15	VDD_RTC	VDD_RTC	P	P	P	drtc
P14	VDDA_ADC	VDDA_ADC	P	P	P	d33th
N16	VDDA_MPLL	VDDA_MPLL	P	P	P	d12t
M13	VDDA_UPLL	VDDA_UPLL	P	P	P	d12t
G4	VDDalive	VDDalive	P	P	P	d12i
J17	VDDalive	VDDalive	P	P	P	d12i

Table 1-2. S3C2440A 289-Pin FBGA Pin Assignments (Sheet 8 of 9) (Continued)

Pin Number	Pin Name	Default Function	I/O State @BUS REQ	I/O State @Sleep	I/O State @nRESET	I/O Type
A1	VDDi	VDDi	P	P	P	d12c
A10	VDDi	VDDi	P	P	P	d12c
A16	VDDi	VDDi	P	P	P	d12c
A6	VDDi	VDDi	P	P	P	d12c
B11	VDDi	VDDi	P	P	P	d12c
F1	VDDi	VDDi	P	P	P	d12c
F16	VDDi	VDDi	P	P	P	d12c
U11	VDDi	VDDi	P	P	P	d12c
L2	VDDiarm	VDDiarm	P	P	P	d12c
T6	VDDiarm	VDDiarm	P	P	P	d12c
T8	VDDiarm	VDDiarm	P	P	P	d12c
U1	VDDiarm	VDDiarm	P	P	P	d12c
J2	VDDiarm	VDDiarm	P	P	P	d12c
U2	VDDiarm	VDDiarm	P	P	P	d12c
A9	VDDMOP	VDDMOP	P	P	P	d33o
B12	VDDMOP	VDDMOP	P	P	P	d33o
B14	VDDMOP	VDDMOP	P	P	P	d33o
B16	VDDMOP	VDDMOP	P	P	P	d33o
B6	VDDMOP	VDDMOP	P	P	P	d33o
C1	VDDMOP	VDDMOP	P	P	P	d33o
F17	VDDMOP	VDDMOP	P	P	P	d33o
J1	VDDOP	VDDOP	P	P	P	d33o
T12	VDDOP	VDDOP	P	P	P	d33o
T3	VDDOP	VDDOP	P	P	P	d33o
K12	VDDOP	VDDOP	P	P	P	d33o
T14	VSSA_ADC	VSSA_ADC	P	P	P	sth
R17	VSSA_MPLL	VSSA_MPLL	P	P	P	st
M12	VSSA_UPLL	VSSA_UPLL	P	P	P	st
A12	VSSi	VSSi	P	P	P	si
A3	VSSi	VSSi	P	P	P	si
A4	VSSi	VSSi	P	P	P	si
B10	VSSi	VSSi	P	P	P	si
C17	VSSi	VSSi	P	P	P	si

Table 1-2. S3C2440A 289-Pin FBGA Pin Assignments (Sheet 9 of 9) (Continued)

Pin Number	Pin Name	Default Function	I/O State @BUS REQ	I/O State @Sleep	I/O State @nRESET	I/O Type
F2	VSSi	VSSi	P	P	P	si
G17	VSSi	VSSi	P	P	P	si
H1	VSSiarm	VSSiarm	P	P	P	si
K1	VSSiarm	VSSiarm	P	P	P	si
T1	VSSiarm	VSSiarm	P	P	P	si
T2	VSSiarm	VSSiarm	P	P	P	si
U10	VSSiarm	VSSiarm	P	P	P	si
U4	VSSiarm	VSSiarm	P	P	P	si
U7	VSSiarm	VSSiarm	P	P	P	si
A11	VSSMOP	VSSMOP	P	P	P	so
A15	VSSMOP	VSSMOP	P	P	P	so
A5	VSSMOP	VSSMOP	P	P	P	so
A7	VSSMOP	VSSMOP	P	P	P	so
B1	VSSMOP	VSSMOP	P	P	P	so
B13	VSSMOP	VSSMOP	P	P	P	so
D16	VSSMOP	VSSMOP	P	P	P	so
D17	VSSMOP	VSSMOP	P	P	P	so
E2	VSSMOP	VSSMOP	P	P	P	so
G1	VSSOP	VSSOP	P	P	P	so
N1	VSSOP	VSSOP	P	P	P	so
U15	VSSOP	VSSOP	P	P	P	so
U3	VSSOP	VSSOP	P	P	P	so
U9	VSSOP	VSSOP	P	P	P	so
H11	VSSOP	VSSOP	P	P	P	so

NOTES:

1. The @BUS REQ. shows the pin state at the external bus, which is used by the other bus master.
2. ' - ' mark indicates the unchanged pin state at Bus Request mode.
3. Hi-z or Pre means Hi-z or early state and it is determined by the setting of MISCCR register.
4. AI/AO means analog input/analog output.
5. P, I, and O mean power, input and output respectively.
6. The I/O state @nRESET shows the pin status in the @nRESET duration below.

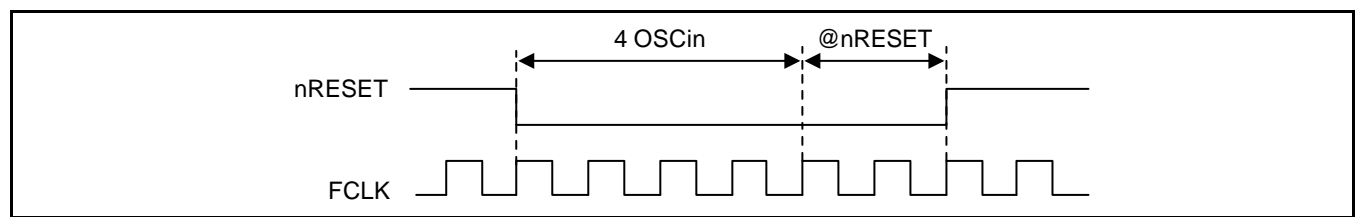

The table below shows I/O types and descriptions.

Input (I)/Output (O) Type	Descriptions
d12i(vdd12ih)	1.2V V_{DD} for alive power
d12c(vdd12ih_core), si(vssih)	1.2V V_{DD}/V_{SS} for internal logic
d33o(vdd33oph), so(vssoph)	3.3V V_{DD}/V_{SS} for external logic
d33th(vdd33th_abb),sth(vssbbh_abb)	3.3V V_{DD}/V_{SS} for analog circuitry
d12t(vdd12t_abb), st(vssbb_abb)	1.2V V_{DD}/V_{SS} for analog circuitry
drtc(vdd30th_rtc)	3.0V V_{DD} for RTC power
t8(phbsu100ct8sm)	Bi-directional pad, LVCMOS schmitt-trigger, 100k Ω pull-up resistor with control, tri-state, lo = 8mA
is(phis)	Input pad, LVCMOS schmitt-trigger level
us(pbusb0)	USB pad
t10(phtot10cd)	5V tolerant output pad, tri-state.
ot(phot8)	Output pad, tri-state, lo = 8mA
b8(phob8)	Output pad, lo = 8mA
t16(phot16sm)	Output pad, tri-state, medium slew rate, lo = 16mA
r10(phiar10_abb)	Analog input pad with 10 Ω resistor
ia(phia_abb)	Analog input pad
gp(phgpad_option)	Pad for analog pin
m26(phsosc26_2440a)	Oscillator cell with enable and feedback resistor
t12(phbsu100ct12sm)	Bi-directional pad, LVCMOS schmitt-trigger, 100k Ω pull-up resistor with control, tri-state, lo = 12mA
d8(phbsd8sm)	Bi-directional pad, LVCMOS schmitt-trigger, open drain, lo = 8mA
t10s(phtot10cd_10_2440a)	output pad, LVCMOS, tri -state, output drive strenth control, lo = 4, 6, 8, 10mA
b12s(phtbsu100ct12cd_12_2440a)	Bi-directional pad, LVCMOS schmitt-trigger, 100k Ω pull-up resistor with control, tri -state,output drive strenth control, lo = 6, 8, 10, 12mA
d2s(phtbsd2_2440a)	Bi-directional pad, LVCMOS schmitt-trigger, open-drain, output drive strenth ignore,
r50(phoar50_abb)	Analog output pad, 50k Ω resistor, separated bulk-bias
t12s(phtot12cd_12_2440a)	output pad, LVCMOS, tri -state, output drive strenth control, lo = 6, 8, 10, 12mA
nc(phnc)	No connection pad

SIGNAL DESCRIPTIONS

Table 1-3. S3C2440A Signal Descriptions (Sheet 1 of 6)

Signal	Input/Output	Descriptions	
Bus Controller			
OM[1:0]	I	OM[1:0] sets S3C2440A in the TEST mode, which is used only at fabrication. Also, it determines the bus width of nGCS0. The pull-up/down resistor determines the logic level during RESET cycle. 00: Nand-boot 01: 16-bit 10: 32-bit 11: Test mode	
ADDR[26:0]	O	ADDR[26:0] (Address Bus) outputs the memory address of the corresponding bank .	
DATA[31:0]	IO	DATA[31:0] (Data Bus) inputs data during memory read and outputs data during memory write. The bus width is programmable among 8/16/32-bit.	
nGCS[7:0]	O	nGCS[7:0] (General Chip Select) are activated when the address of a memory is within the address region of each bank. The number of access cycles and the bank size can be programmed.	
nWE	O	nWE (Write Enable) indicates that the current bus cycle is a write cycle.	
nOE	O	nOE (Output Enable) indicates that the current bus cycle is a read cycle.	
nXBREQ	I	nXBREQ (Bus Hold Request) allows another bus master to request control of the local bus. BACK active indicates that bus control has been granted.	
nXBACK	O	nXBACK (Bus Hold Acknowledge) indicates that the S3C2440A has surrendered control of the local bus to another bus master.	
nWAIT	I	nWAIT requests to prolong a current bus cycle. As long as nWAIT is L, the current bus cycle cannot be completed.	
SDRAM/SRAM			
nSRAS	O	SDRAM row address strobe	
nSCAS	O	SDRAM column address strobe	
nSCS[1:0]	O	SDRAM chip select	
DQM[3:0]	O	SDRAM data mask	
SCLK[1:0]	O	SDRAM clock	
SCKE	O	SDRAM clock enable	
nBE[3:0]	O	Upper byte/lower byte enable (In case of 16-bit SRAM)	
nWBE[3:0]	O	Write byte enable	
NAND Flash			
CLE	O	Command latch enable	
ALE	O	Address latch enable	
nFCE	O	Nand flash chip enable	
nFRE	O	Nand flash read enable	
nFWE	O	Nand flash write enable	
NCON	I	Nand flash configuration	* If NAND flash controller isn't used, it has to be pull-up. (VDDMOP)
FRnB	I	Nand flash ready/busy	

Table 1-3. S3C2440A Signal Descriptions (Sheet 2 of 6) (Continued)

Signal	Input/ Output	Descriptions
LCD Control Unit		
VD[23:0]	O	STN/TFT/SEC TFT: LCD data bus
LCD_PWREN	O	STN/TFT/SEC TFT: LCD panel power enable control signal
VCLK	O	STN/TFT: LCD clock signal
VFRAME	O	STN: LCD frame signal
VLINE	O	STN: LCD line signal
VM	O	STN: VM alternates the polarity of the row and column voltage
VSYNC	O	TFT: Vertical synchronous signal
HSYNC	O	TFT: Horizontal synchronous signal
VDEN	O	TFT: Data enable signal
LEND	O	TFT: Line end signal
STV	O	SEC TFT: SEC(Samsung Electronics Company) TFT LCD panel control signal
CPV	O	SEC TFT: SEC(Samsung Electronics Company) TFT LCD panel control signal
LCD_HCLK	O	SEC TFT: SEC(Samsung Electronics Company) TFT LCD panel control signal
TP	O	SEC TFT: SEC(Samsung Electronics Company) TFT LCD panel control signal
STH	O	SEC TFT: SEC(Samsung Electronics Company) TFT LCD panel control signal
LCD_LPCOE	O	SEC TFT: Timing control signal for specific TFT LCD
LCD_LPCREV	O	SEC TFT: Timing control signal for specific TFT LCD
LCD_LPCREVB	O	SEC TFT: Timing control signal for specific TFT LCD
CAMERA Interface		
CAMRESET	O	Software reset to the camera
CAMCLKOUT	O	Master clock to the camera
CAMPCLK	I	Pixel clock from camera
CAMHREF	I	Horizontal sync signal from camera
CAMVSYNC	I	Vertical sync signal from camera
CAMDATA[7:0]	I	Pixel data for YCbCr
Interrupt Control Unit		
EINT[23:0]	I	External interrupt request
DMA		
nXDREQ[1:0]	I	External DMA request
nXDACK[1:0]	O	External DMA acknowledge

Table 1-3. S3C2440A Signal Descriptions (Sheet 3 of 6) (Continued)

Signal	Input/Output	Descriptions
UART		
RxD[2:0]	I	UART receives data input
TxD[2:0]	O	UART transmits data output
nCTS[1:0]	I	UART clear to send input signal
nRTS[1:0]	O	UART request to send output signal
UEXTCLK	I	External clock input for UART
ADC		
AIN[7:0]	AI	ADC input[7:0]. If it isn't used pin, it has to be low (ground).
Vref	AI	ADC Vref
IIC-Bus		
IICSDA	IO	IIC-bus data
IIC_SCL	IO	IIC-bus clock
IIS-Bus		
I2SLRCK	IO	IIS-bus channel select clock
I2SSDO	O	IIS-bus serial data output
I2SSDI	I	IIS-bus serial data input
I2SSCLK	IO	IIS-bus serial clock
CDCLK	O	CODEC system clock
AC'97		
AC_SYNC		48kHz fixed rate sample sync
AC_BIT_CLK	IO	12.288MHz serial data clock
AC_nRESET	O	AC'97 Master H/W Reset
AC_SDATA_IN	I	Serial, time division multiplexed, AC'97 input stream
AC_SDATA_OUT	O	Serial, time division multiplexed, AC'97 output stream
Touch Screen		
nXPON	O	Plus X-axis on-off control signal
XMON	O	Minus X-axis on-off control signal
nYPON	O	Plus Y-axis on-off control signal
YMON	O	Minus Y-axis on-off control signal
USB Host		
DN[1:0]	IO	DATA(-) from USB host. (Need to 15kΩ pull-down)
DP[1:0]	IO	DATA(+) from USB host. (Need to 15kΩ pull-down)
USB Device		
PDN0	IO	DATA(-) for USB peripheral. (Need to 470kΩ pull-down for power consumption in sleep mode)
PDP0	IO	DATA(+) for USB peripheral. (Need to 1.5kΩ pull-up)

Table 1-3. S3C2440A Signal Descriptions (Sheet 4 of 6) (Continued)

Signal	Input/Output	Description
SPI		
SPIMISO[1:0]	IO	SPIMISO is the master data input line, when SPI is configured as a master. When SPI is configured as a slave, these pins reverse its role.
SPIMOSI[1:0]	IO	SPIMOSI is the master data output line, when SPI is configured as a master. When SPI is configured as a slave, these pins reverse its role.
SPICLK[1:0]	IO	SPI clock
nSS[1:0]	I	SPI chip select(only for slave mode)
SD		
SDDAT[3:0]	IO	SD receive/transmit data
SDCMD	IO	SD receive response/ transmit command
SDCLK	O	SD clock
General Port		
GPn[129:0]	IO	General input/output ports (some ports are output only)
TIMMER/PWM		
TOUT[3:0]	O	Timer output[3:0]
TCLK[1:0]	I	External timer clock input
JTAG TEST LOGIC		
nTRST	I	nTRST (TAP Controller Reset) resets the TAP controller at start. If debugger is used, A 10K pull-up resistor has to be connected. If debugger (black ICE) is not used, nTRST pin must be issued by a low active pulse (Typically connected to nRESET).
TMS	I	TMS (TAP Controller Mode Select) controls the sequence of the TAP controller's states. A 10K pull-up resistor has to be connected to TMS pin.
TCK	I	TCK (TAP Controller Clock) provides the clock input for the JTAG logic. A 10K pull-up resistor must be connected to TCK pin.
TDI	I	TDI (TAP Controller Data Input) is the serial input for test instructions and data. A 10K pull-up resistor must be connected to TDI pin.
TDO	O	TDO (TAP Controller Data Output) is the serial output for test instructions and data.

Table 1-3. S3C2440A Signal Descriptions (Sheet 5 of 6) (Continued)

Signal	Input/Output	Description
Reset, Clock & Power		
XTOpll	AO	Crystal Output for internal osc circuit. When OM[3:2] = 00b, XTIpII is used for MPLL CLK source and UPLL CLK source. When OM[3:2] = 01b, XTIpII is used for MPLL CLK source only. When OM[3:2] = 10b, XTIpII is used for UPLL CLK source only. If it isn't used, it has to be a floating pin.
MPLLCAP	AI	Loop filter capacitor for main clock.
UPLLCAP	AI	Loop filter capacitor for USB clock.
XTIrtc	AI	32 kHz crystal input for RTC. If it isn't used, it has to be High (VDDRTC).
XTOrtc	AO	32 kHz crystal output for RTC. If it isn't used, it has to be Float.
CLKOUT[1:0]	O	Clock output signal. The CLKSEL of MISCCR register configures the clock output mode among the MPLL CLK, UPLL CLK, FCLK, HCLK, PCLK.
nRESET	ST	nRESET suspends any operation in progress and places S3C2440A into a known reset state. For a reset, nRESET must be held to L level for at least 4 OSCin after the processor power has been stabilized.
nRSTOUT	O	For external device reset control (nRSTOUT = nRESET & nWDTRST & SW_RESET)
PWREN	O	1.2V/1.3V core power on-off control signal
nBATT_FLT	I	Probe for battery state(Does not wake up at Sleep mode in case of low battery state). If it isn't used, it has to be High (VDDOP).
OM[3:2]	I	OM[3:2] determines how the clock is made. OM[3:2] = 00b, Crystal is used for MPLL CLK source and UPLL CLK source. OM[3:2] = 01b, Crystal is used for MPLL CLK source and EXTCLK is used for UPLL CLK source. OM[3:2] = 10b, EXTCLK is used for MPLL CLK source and Crystal is used for UPLL CLK source. OM[3:2] = 11b, EXTCLK is used for MPLL CLK source and UPLL CLK source.
EXTCLK	I	External clock source. When OM[3:2] = 11b, EXTCLK is used for MPLL CLK source and UPLL CLK source. When OM[3:2] = 10b, EXTCLK is used for MPLL CLK source only. When OM[3:2] = 01b, EXTCLK is used for UPLL CLK source only. If it isn't used, it has to be High (VDDOP).
XTIpII	AI	Crystal Input for internal osc circuit. When OM[3:2] = 00b, XTIpII is used for MPLL CLK source and UPLL CLK source. When OM[3:2] = 01b, XTIpII is used for MPLL CLK source only. When OM[3:2] = 10b, XTIpII is used for UPLL CLK source only. If it isn't used, XTIpII has to be High (VDDOP).

Table 1-3. S3C2440A Signal Descriptions (Sheet 6 of 6) (Continued)

Signal	Input/Output	Description
Power		
VDDalive	P	S3C2440A reset block and port status register V_{DD} . It should be always supplied whether in normal mode or in Sleep mode.
VDDiarm	P	S3C2440A core logic V_{DD} for ARM core.
VDDi	P	S3C2440A core logic V_{DD} for Internal block.
VSSi/VSSiarm	P	S3C2440A core logic V_{SS}
VDDi_MPLL	P	S3C2440A MPLL analog and digital V_{DD} .
VSSi_MPLL	P	S3C2440A MPLL analog and digital V_{SS} .
VDDOP	P	S3C2440A I/O port VDD (3.3V)
VDDMOP	P	S3C2440A memory I/O V_{DD} 3.3V: SCLK up to 135 MHz 2.5V: SCLK up to 135 MHz 1.8V: SCLK up to 93 MHz
VSSOP	P	S3C2440A I/O port VSS
RTCVDD	P	RTC V_{DD} (3.0V, Input range: 1.8 ~ 3.6V) This pin must be connected to power properly if RTC isn't used.
VDDi_UPLL	P	S3C2440A UPLL analog and digital V_{DD}
VSSi_UPLL	P	S3C2440A UPLL analog and digital V_{SS}
VDDA_ADC	P	S3C2440A ADC V_{DD} (3.3V)
VSSA_ADC	P	S3C2440A ADC V_{SS}

NOTES:

1. I/O means Input/Output.
2. AI/AO means analog input/analog output.
3. ST means schmitt-trigger.
4. P means power.

S3C2440A SPECIAL REGISTERS

Table 1-4. S3C2440A Special Registers (Sheet 1 of 14)

Register Name	Address (B. Endian)	Address (L. Endian)	Acc. Unit	Read/Write	Function
Memory Controllers					
BWSCON	0x48000000		W	R/W	Bus width & wait status control
BANKCON0	0x48000004				Boot ROM control
BANKCON1	0x48000008				BANK1 control
BANKCON2	0x4800000C				BANK2 control
BANKCON3	0x48000010				BANK3 control
BANKCON4	0x48000014				BANK4 control
BANKCON5	0x48000018				BANK5 control
BANKCON6	0x4800001C				BANK6 control
BANKCON7	0x48000020				BANK7 control
REFRESH	0x48000024				DRAM/SDRAM refresh control
BANKSIZE	0x48000028				Flexible bank size
MRSRB6	0x4800002C				Mode register set for SDRAM BANK6
MRSRB7	0x48000030				Mode register set for SDRAM BANK7

Table 1-4. S3C2440A Special Registers (Sheet 2 of 14) (Continued)

Register Name	Address (B. Endian)	Address (L. Endian)	Acc. Unit	Read/ Write	Function
USB Host Controller					
HcRevision	0x49000000	←	W		Control and status group
HcControl	0x49000004				
HcCommonStatus	0x49000008				
HcInterruptStatus	0x4900000C				
HcInterruptEnable	0x49000010				
HcInterruptDisable	0x49000014				
HcHCCA	0x49000018				Memory pointer group
HcPeriodCuttentED	0x4900001C				
HcControlHeadED	0x49000020				
HcControlCurrentED	0x49000024				
HcBulkHeadED	0x49000028				
HcBulkCurrentED	0x4900002C				
HcDoneHead	0x49000030				Frame counter group
HcRmInterval	0x49000034				
HcFmRemaining	0x49000038				
HcFmNumber	0x4900003C				
HcPeriodicStart	0x49000040				
HcLSThreshold	0x49000044				
HcRhDescriptorA	0x49000048				Root hub group
HcRhDescriptorB	0x4900004C				
HcRhStatus	0x49000050				
HcRhPortStatus1	0x49000054				
HcRhPortStatus2	0x49000058				
Interrupt Controller					
SRCPND	0X4A000000	←	W	R/W	Interrupt request status
INTMOD	0X4A000004			W	Interrupt mode control
INTMSK	0X4A000008			R/W	Interrupt mask control
PRIORITY	0X4A00000C			W	IRQ priority control
INTPND	0X4A000010			R/W	Interrupt request status
INTOFFSET	0X4A000014			R	Interrupt request source offset
SUBSRCPND	0X4A000018			R/W	Sub source pending
INTSUBMSK	0X4A00001C			R/W	Interrupt sub mask

Table 1-4. S3C2440A Special Registers (Sheet 3 of 14) (Continued)

Register Name	Address (B. Endian)	Address (L. Endian)	Acc. Unit	Read/Write	Function
DMA					
DISRC0	0x4B000000	←	W	R/W	DMA 0 initial source
DISRCC0	0x4B000004				DMA 0 initial source control
DIDST0	0x4B000008				DMA 0 initial destination
DIDSTC0	0x4B00000C				DMA 0 initial destination control
DCON0	0x4B000010				DMA 0 control
DSTAT0	0x4B000014			R	DMA 0 count
DCSRC0	0x4B000018				DMA 0 current source
DCDST0	0x4B00001C				DMA 0 current destination
DMASKTRIG0	0x4B000020			R/W	DMA 0 mask trigger
DISRC1	0x4B000040				DMA 1 initial source
DISRCC1	0x4B000044				DMA 1 initial source control
DIDST1	0x4B000048				DMA 1 initial destination
DIDSTC1	0x4B00004C				DMA 1 initial destination control
DCON1	0x4B000050				DMA 1 control
DSTAT1	0x4B000054			R	DMA 1 count
DCSRC1	0x4B000058				DMA 1 current source
DCDST1	0x4B00005C				DMA 1 current destination
DMASKTRIG1	0x4B000060			R/W	DMA 1 mask trigger
DISRC2	0x4B000080				DMA 2 initial source
DISRCC2	0x4B000084				DMA 2 initial source control
DIDST2	0x4B000088				DMA 2 initial destination
DIDSTC2	0x4B00008C				DMA 2 initial destination control
DCON2	0x4B000090				DMA 2 control
DSTAT2	0x4B000094			R	DMA 2 count
DCSRC2	0x4B000098				DMA 2 current source
DCDST2	0x4B00009C				DMA 2 current destination
DMASKTRIG2	0x4B0000A0			R/W	DMA 2 mask trigger
DISRC3	0x4B0000C0	←	W	R/W	DMA 3 initial source
DISRCC3	0x4B0000C4				DMA 3 initial source control
DIDST3	0x4B0000C8				DMA 3 initial destination
DIDSTC3	0x4B0000CC				DMA 3 initial destination control
DCON3	0x4B0000D0				DMA 3 control
DSTAT3	0x4B0000D4			R	DMA 3 count
DCSRC3	0x4B0000D8				DMA 3 current source
DCDST3	0x4B0000DC				DMA 3 current destination
DMASKTRIG3	0x4B0000E0			R/W	DMA 3 mask trigger

Table 1-4. S3C2440A Special Registers (Sheet 4 of 14) (Continued)

Register Name	Address (B. Endian)	Address (L. Endian)	Acc. Unit	Read/Write	Function
Clock & Power Management					
LOCKTIME	0x4C000000	←	W	R/W	PLL lock time counter
MPLLCON	0x4C000004				MPLL control
UPLLCON	0x4C000008				UPLL control
CLKCON	0x4C00000C				Clock generator control
CLKSLOW	0x4C000010				Slow clock control
CLKDIVN	0x4C000014				Clock divider control
CAMDIVN	0x4C000018				Camera clock divider control
LCD Controller					
LCDCON1	0X4D000000	←	W	R/W	LCD control 1
LCDCON2	0X4D000004				LCD control 2
LCDCON3	0X4D000008				LCD control 3
LCDCON4	0X4D00000C				LCD control 4
LCDCON5	0X4D000010				LCD control 5
LCDSADDR1	0X4D000014				STN/TFT: frame buffer start address 1
LCDSADDR2	0X4D000018				STN/TFT: frame buffer start address 2
LCDSADDR3	0X4D00001C				STN/TFT: virtual screen address set
REDLUT	0X4D000020				STN: red lookup table
GREENLUT	0X4D000024				STN: green lookup table
BLUELUT	0X4D000028				STN: blue lookup table
DITHMODE	0X4D00004C				STN: dithering mode
TPAL	0X4D000050				TFT: temporary palette
LCDINTPND	0X4D000054				LCD interrupt pending
LCDSRCPND	0X4D000058				LCD interrupt source
LCDINTMSK	0X4D00005C				LCD interrupt mask
TCONSEL	0X4D000060				TCON(LPC3600/LCC3600) control

Table 1-4. S3C2440A Special Registers (Sheet 5 of 14) (Continued)

Register Name	Address (B. Endian)	Address (L. Endian)	Acc. Unit	Read/Write	Function
NAND Flash					
NFCONF	0x4E000000	←	W	R/W	NAND flash configuration
NFCONT	0x4E000004				NAND flash control
NFCMD	0x4E000008				NAND flash command
NFADDR	0x4E00000C				NAND flash address
NFDATA	0x4E000010				NAND flash data
NFMECC0	0x4E000014				NAND flash main area ECC0/1
NFMECC1	0x4E000018				NAND flash main area ECC2/3
NFSECC	0x4E00001C				NAND flash spare area ECC
NFSTAT	0x4E000020				NAND flash operation status
NFSTAT0	0x4E000024				NAND flash ECC status for I/O[7:0]
NFSTAT1	0x4E000028				NAND flash ECC status for I/O[15:8]
NFMECC0	0x4E00002C			R	NAND flash main area ECC0 status
NFMECC1	0x4E000030				NAND flash main area ECC1 status
NFSECC	0x4E000034				NAND flash spare area ECC status
NFSBLK	0x4E000038			R/W	NAND flash start block address
NFEBLK	0x4E00003C				NAND flash end block address

Table 1-4. S3C2440A Special Registers (Sheet 6 of 14) (Continued)

Register Name	Address (B. Endian)	Address (L. Endian)	Acc. Unit	Read/Write	Function
Camera Interface					
CISRCFMT	0x4F000000	←	W	RW	Input source format
CIWDOFST	0x4F000004				Window offset register
CIGCTRL	0x4F000008				Global control register
CICOYSA1	0x4F000018				Y 1 st frame start address for codec DMA
CICOYSA2	0x4F00001C				Y 2 nd frame start address for codec DMA
CICOYSA3	0x4F000020				Y 3 rd frame start address for codec DMA
CICOYSA4	0x4F000024				Y 4 th frame start address for codec DMA
CICOCBSA1	0x4F000028				Cb 1 st frame start address for codec DMA
CICOCBSA2	0x4F00002C				Cb 2 nd frame start address for codec DMA
CICOCBSA3	0x4F000030				Cb 3 rd frame start address for codec DMA
CICOCBSA4	0x4F000034				Cb 4 th frame start address for codec DMA
CICOCRSA1	0x4F000038				Cr 1 st frame start address for codec DMA
CICOCRSA2	0x4F00003C				Cr 2 nd frame start address for codec DMA
CICOCRSA3	0x4F000040				Cr 3 rd frame start address for codec DMA
CICOCRSA4	0x4F000044				Cr 4 th frame start address for codec DMA
CICOTRGFMT	0x4F000048				Target image format of codec DMA
CICOCTRL	0x4F00004C				Codec DMA control related
CICOSCPRERATIO	0x4F000050				Codec pre-scaler ratio control
CICOSCPREDST	0x4F000054				Codec pre-scaler destination format
CICOSCCTRL	0x4F000058				Codec main-scaler control
CICOTAREA	0x4F00005C				Codec scaler target area
CICOSTATUS	0x4F000064				Codec path status
CIPRCLRSA1	0x4F00006C				RGB 1 st frame start address for preview DMA
CIPRCLRSA2	0x4F000070				RGB 2 nd frame start address for preview DMA
CIPRCLRSA3	0x4F000074				RGB 3 rd frame start address for preview DMA
CIPRCLRSA4	0x4F000078				RGB 4 th frame start address for preview DMA
CIPRTRGFMT	0x4F00007C				Target image format of preview DMA
CIPRCTRL	0x4F000080				Preview DMA control related
CIPRSCPRERATIO	0x4F000084				Preview pre-scaler ratio control
CIPRSCPREDST	0x4F000088				Preview pre-scaler destination format
CIPRSCCTRL	0x4F00008C				Preview main-scaler control
CIPRTAREA	0x4F000090				Preview scaler target area
CIPRSTATUS	0x4F000098				Preview path status
CIIMGCP	0x4F0000A0				Image capture enable command

Table 1-4. S3C2440A Special Registers (Sheet 7 of 14) (Continued)

Register Name	Address (B. Endian)	Address (L. Endian)	Acc. Unit	Read/Write	Function
UART					
ULCON0	0x50000000	←	W	R/W	UART 0 line control
UCON0	0x50000004				UART 0 control
UFCON0	0x50000008				UART 0 FIFO control
UMCON0	0x5000000C				UART 0 modem control
UTRSTAT0	0x50000010			R	UART 0 Tx/Rx status
UERSTAT0	0x50000014				UART 0 Rx error status
UFSTAT0	0x50000018				UART 0 FIFO status
UMSTAT0	0x5000001C				UART 0 modem status
UTXH0	0x50000023	0x50000020	B	W	UART 0 transmission hold
URXH0	0x50000027	0x50000024		R	UART 0 receive buffer
UBRDIV0	0x50000028	←	W	R/W	UART 0 baud rate divisor
ULCON1	0x50004000				UART 1 line control
UCON1	0x50004004				UART 1 control
UFCON1	0x50004008				UART 1 FIFO control
UMCON1	0x5000400C				UART 1 modem control
UTRSTAT1	0x50004010			R	UART 1 Tx/Rx status
UERSTAT1	0x50004014				UART 1 Rx error status
UFSTAT1	0x50004018				UART 1 FIFO status
UMSTAT1	0x5000401C				UART 1 modem status
UTXH1	0x50004023	0x50004020	B	W	UART 1 transmission hold
URXH1	0x50004027	0x50004024		R	UART 1 receive buffer
UBRDIV1	0x50004028	←	W	R/W	UART 1 baud rate divisor
ULCON2	0x50008000				UART 2 line control
UCON2	0x50008004				UART 2 control
UFCON2	0x50008008				UART 2 FIFO control
UTRSTAT2	0x50008010			R	UART 2 Tx/Rx status
UERSTAT2	0x50008014				UART 2 Rx error status
UFSTAT2	0x50008018				UART 2 FIFO status
UTXH2	0x50008023	0x50008020	B	W	UART 2 transmission hold
URXH2	0x50008027	0x50008024		R	UART 2 receive buffer
UBRDIV2	0x50008028	←	W	R/W	UART 2 baud rate divisor

Table 1-4. S3C2440A Special Registers (Sheet 8 of 14) (Continued)

Register Name	Address (B. Endian)	Address (L. Endian)	Acc. Unit	Read/ Write	Function
PWM Timer					
TCFG0	0x51000000	←	W	R/W	Timer configuration
TCFG1	0x51000004				Timer configuration
TCON	0x51000008				Timer control
TCNTB0	0x5100000C				Timer count buffer 0
TCMPB0	0x51000010				Timer compare buffer 0
TCNTO0	0x51000014			R	Timer count observation 0
TCNTB1	0x51000018			R/W	Timer count buffer 1
TCMPB1	0x5100001C				Timer compare buffer 1
TCNTO1	0x51000020			R	Timer count observation 1
TCNTB2	0x51000024			R/W	Timer count buffer 2
TCMPB2	0x51000028				Timer compare buffer 2
TCNTO2	0x5100002C			R	Timer count observation 2
TCNTB3	0x51000030			R/W	Timer count buffer 3
TCMPB3	0x51000034				Timer compare buffer 3
TCNTO3	0x51000038			R	Timer count observation 3
TCNTB4	0x5100003C			R/W	Timer count buffer 4
TCNTO4	0x51000040			R	Timer count observation 4

Table 1-4. S3C2440A Special Registers (Sheet 9 of 14) (Continued)

Register Name	Address (B. Endian)	Address (L. Endian)	Acc. Unit	Read/ Write	Function
USB Device					
FUNC_ADDR_REG	0x52000143	0x52000140	B	R/W	Function address
PWR_REG	0x52000147	0x52000144			Power management
EP_INT_REG	0x5200014B	0x52000148			EP interrupt pending and clear
USB_INT_REG	0x5200015B	0x52000158			USB interrupt pending and clear
EP_INT_EN_REG	0x5200015F	0x5200015C			Interrupt enable
USB_INT_EN_REG	0x5200016F	0x5200016C			Interrupt enable
FRAME_NUM1_REG	0x52000173	0x52000170		R	Frame number lower byte
FRAME_NUM2_REG	0x52000177	0x52000174			Frame number higher byte
INDEX_REG	0x5200017B	0x52000178		R/W	Register index
EP0_CSR	0x52000187	0x52000184			Endpoint 0 status
IN_CSR1_REG	0x52000187	0x52000184			In endpoint control status
IN_CSR2_REG	0x5200018B	0x52000188			In endpoint control status
MAXP_REG	0x52000183	0x52000180			Endpoint max packet
OUT_CSR1_REG	0x52000193	0x52000190			Out endpoint control status
OUT_CSR2_REG	0x52000197	0x52000194			Out endpoint control status
OUT_FIFO_CNT1_REG	0x5200019B	0x52000198		R	Endpoint out write count
OUT_FIFO_CNT2_REG	0x5200019F	0x5200019C			Endpoint out write count
EP0_FIFO	0x520001C3	0x520001C0		R/W	Endpoint 0 FIFO
EP1_FIFO	0x520001C7	0x520001C4			Endpoint 1 FIFO
EP2_FIFO	0x520001CB	0x520001C8			Endpoint 2 FIFO
EP3_FIFO	0x520001CF	0x520001CC			Endpoint 3 FIFO
EP4_FIFO	0x520001D3	0x520001D0			Endpoint 4 FIFO
EP1_DMA_CON	0x52000203	0x52000200			EP1 DMA Interface control
EP1_DMA_UNIT	0x52000207	0x52000204			EP1 DMA Tx unit counter
EP1_DMA_FIFO	0x5200020B	0x52000208			EP1 DMA Tx FIFO counter
EP1_DMA_TTC_L	0x5200020F	0x5200020C			EP1 DMA Total Tx counter
EP1_DMA_TTC_M	0x52000213	0x52000210			EP1 DMA Total Tx counter
EP1_DMA_TTC_H	0x52000217	0x52000214			EP1 DMA Total Tx counter
EP2_DMA_CON	0x5200021B	0x52000218	B	R/W	EP2 DMA interface control
EP2_DMA_UNIT	0x5200021F	0x5200021C			EP2 DMA Tx Unit counter
EP2_DMA_FIFO	0x52000223	0x52000220			EP2 DMA Tx FIFO counter
EP2_DMA_TTC_L	0x52000227	0x52000224			EP2 DMA total Tx counter
EP2_DMA_TTC_M	0x5200022B	0x52000228			EP2 DMA total Tx counter

Table 1-4. S3C2440A Special Registers (Sheet 10 of 14) (Continued)

Register Name	Address (B. Endian)	Address (L. Endian)	Acc. Unit	Read/ Write	Function
USB Device (Continued)					
EP2_DMA_TTC_H	0x5200022F	0x5200022C			EP2 DMA Total Tx counter
EP3_DMA_CON	0x52000243	0x52000240			EP3 DMA Interface control
EP3_DMA_UNIT	0x52000247	0x52000244			EP3 DMA Tx Unit counter
EP3_DMA_FIFO	0x5200024B	0x52000248			EP3 DMA Tx FIFO counter
EP3_DMA_TTC_L	0x5200024F	0x5200024C			EP3 DMA Total Tx counter
EP3_DMA_TTC_M	0x52000253	0x52000250			EP3 DMA Total Tx counter
EP3_DMA_TTC_H	0x52000257	0x52000254			EP3 DMA Total Tx counter
EP4_DMA_CON	0x5200025B	0x52000258			EP4 DMA Interface control
EP4_DMA_UNIT	0x5200025F	0x5200025C			EP4 DMA Tx Unit counter
EP4_DMA_FIFO	0x52000263	0x52000260			EP4 DMA Tx FIFO counter
EP4_DMA_TTC_L	0x52000267	0x52000264			EP4 DMA Total Tx counter
EP4_DMA_TTC_M	0x5200026B	0x52000268			EP4 DMA Total Tx counter
EP4_DMA_TTC_H	0x5200026F	0x5200026C			EP4 DMA Total Tx counter
Watchdog Timer					
WTCON	0x53000000	←	W	R/W	Watchdog timer mode
WTDAT	0x53000004				Watchdog timer data
WTCNT	0x53000008				Watchdog timer count
IIC					
IICCON	0x54000000	←	W	R/W	IIC control
IICSTAT	0x54000004				IIC status
IICADD	0x54000008				IIC address
IICDS	0x5400000C				IIC data shift
IICLC	0x54000010				IIC multi-master line control
IIS					
IISCON	0x55000000,02	0x55000000	HW,W	R/W	IIS control
IISMOD	0x55000004,06	0x55000004			IIS mode
IISPSR	0x55000008,0A	0x55000008			IIS prescaler
IISFCON	0x5500000C,0E	0x5500000C			IIS FIFO control
IISFIFO	0x55000012	0x55000010	HW		IIS FIFO entry

Table 1-4. S3C2440A Special Registers (Sheet 11 of 14) (Continued)

Register Name	Address (B. Endian)	Address (L. Endian)	Acc. Unit	Read/Write	Function
I/O port					
GPACON	0x56000000	←	W	R/W	Port A control
GPADAT	0x56000004				Port A data
GPBCON	0x56000010				Port B control
GPBDAT	0x56000014				Port B data
GPBUP	0x56000018				Pull-up control B
GPCCON	0x56000020				Port C control
GPCDAT	0x56000024				Port C data
GPCUP	0x56000028				Pull-up control C
GPDCON	0x56000030				Port D control
GPDDA1T	0x56000034				Port D data
GPDUP	0x56000038				Pull-up control D
GPECON	0x56000040				Port E control
GPEDAT	0x56000044				Port E data
GPEUP	0x56000048				Pull-up control E
GPFCON	0x56000050				Port F control
GPFDAT	0x56000054				Port F data
GPFUP	0x56000058				Pull-up control F
GPGCON	0x56000060				Port G control
GPGDAT	0x56000064				Port G data
GPGUP	0x56000068				Pull-up control G
GPHCON	0x56000070				Port H control
GPHDAT	0x56000074				Port H data
GPHUP	0x56000078				Pull-up control H
GPJCON	0x560000D0				Port J control
GPJDAT	0x560000D4				Port J data
GPJUP	0x560000D8				Pull-up control J
MISCCR	0x56000080				Miscellaneous control
DCLKCON	0x56000084				DCLK0/1 control
EXTINT0	0x56000088				External interrupt control register 0
EXTINT1	0x5600008C				External interrupt control register 1
EXTINT2	0x56000090				External interrupt control register 2

Table 1-4. S3C2440A Special Registers (Sheet 12 of 14) (Continued)

Register Name	Address (B. Endian)	Address (L. Endian)	Acc. Unit	Read/Write	Function
i/o port (continued)					
EINTFLT0	0x56000094	←	W	R/W	Reserved
EINTFLT1	0x56000098				Reserved
EINTFLT2	0x5600009C				External interrupt filter control register 2
EINTFLT3	0x560000A0				External interrupt filter control register 3
EINTMASK	0x560000A4				External interrupt mask
EINTPEND	0x560000A8				External interrupt pending
GSTATUS0	0x560000AC			R	External pin status
GSTATUS1	0x560000B0			R/W	Chip ID
GSTATUS2	0x560000B4				Reset status
GSTATUS3	0x560000B8				Inform register
GSTATUS4	0x560000BC				Inform register
MSLCON	0x560000CC				Memory sleep control register
RTC					
RTCCON	0x57000043	0x57000040	B	R/W	RTC control
TICNT	0x57000047	0x57000044			Tick time count
RTCALM	0x57000053	0x57000050			RTC alarm control
ALMSEC	0x57000057	0x57000054			Alarm second
ALMMIN	0x5700005B	0x57000058			Alarm minute
ALMHOUR	0x5700005F	0x5700005C			Alarm hour
ALMDATE	0x57000063	0x57000060			alarm day
ALMMON	0x57000067	0x57000064			Alarm month
ALMYEAR	0x5700006B	0x57000068			Alarm year
BCDSEC	0x57000073	0x57000070			BCD second
BCDMIN	0x57000077	0x57000074			BCD minute
BCDHOUR	0x5700007B	0x57000078			BCD hour
BCDDATE	0x5700007F	0x5700007C			BCD day
BCDDAY	0x57000083	0x57000080			BCD date
BCDMON	0x57000087	0x57000084			BCD month
BCDYEAR	0x5700008B	0x57000088			BCD year

Table 1-4. S3C2440A Special Registers (Sheet 13 of 14) (Continued)

Register Name	Address (B. Endian)	Address (L. Endian)	Acc. Unit	Read/Write	Function
A/D Converter					
ADCCON	0x58000000	←	W	R/W	ADC control
ADCTSC	0x58000004				ADC touch screen control
ADCDLY	0x58000008				ADC start or interval delay
ADCDAT0	0x5800000C			R	ADC conversion data
ADCDAT1	0x58000010				ADC conversion data
ADCUPDN	0x58000014			R/W	Stylus up or down interrupt status
SPI					
SPCON0,1	0x59000000,20	←	W	R/W	SPI control
SPSTA0,1	0x59000004,24			R	SPI status
SPPIN0,1	0x59000008,28			R/W	SPI pin control
SPPRE0,1	0x5900000C,2C				SPI baud rate prescaler
SPTDAT0,1	0x59000010,30				SPI Tx data
SPRDAT0,1	0x59000014,34			R	SPI Rx data
SD Interface					
SDICON	0x5A000000	←	W	R/W	SDI control
SDIPRE	0x5A000004				SDI baud rate prescaler
SDICARG	0x5A000008				SDI command argument
SDICCON	0x5A00000C				SDI command control
SDICSTA	0x5A000010			R/(C)	SDI command status
SDIRSP0	0x5A000014			R	SDI response
SDIRSP1	0x5A000018				SDI response
SDIRSP2	0x5A00001C				SDI response
SDIRSP3	0x5A000020				SDI response
SDIDTIMER	0x5A000024			R/W	SDI data / busy timer
SDIBSIZE	0x5A000028				SDI block size
SDIDCON	0x5A00002C				SDI data control
SDIDCNT	0x5A000030			R	SDI data remain counter
SDIDSTA	0x5A000034			R/(C)	SDI data status
SDIFSTA	0x5A000038			R	SDI FIFO status
SDIIMSK	0x5A00003C	←	W		SDI interrupt mask
SDIDAT	0x5A000043	0x5A000040	B	R/W	SDI data

Table 1-4. S3C2440A Special Registers (Sheet 14 of 14) (Continued)

Register Name	Address (B. Endian)	Address (L. Endian)	Acc. Unit	Read/Write	Function
AC97 Audio-CODEC Interface					
AC_GLBCTRL	0x5B000000	←	W	R/W	AC97 global control register
AC_GLBSTAT	0x5B000004			R	AC97 global status register
AC_CODEC_CMD	0x5B000008			R/W	AC97 codec command register
AC_CODEC_STAT	0x5B00000C			R	AC97 codec status register
AC_PCMADDR	0x5B000010				AC97 PCM out/in channel FIFO address register
AC_MICADDR	0x5B000014				AC97 mic in channel FIFO address register
AC_PCMDATA	0x5B000018			R/W	AC97 PCM out/in channel FIFO data register
AC_MICDATA	0x5B00001C				AC97 MIC in channel FIFO data register

Cautions on S3C2440A Special Registers

1. In the little endian mode 'L', endian address must be used. In the big endian mode 'B' endian address must be used.
2. The special registers have to be accessed for each recommended access unit.
3. All registers except ADC registers, RTC registers and UART registers must be read/write in word unit (32-bit) in little/big endian.
4. Make sure that the ADC registers, RTC registers and UART registers be read/write by the specified access unit and the specified address. Moreover, one must carefully consider which endian mode is used.
5. W : 32-bit register, which must be accessed by LDR/STR or int type pointer (int *).
HW : 16-bit register, which must be accessed by LDRH/STRH or short int type pointer (short int *).
B : 8-bit register, which must be accessed by LDRB/STRB or char type pointer (char int *).

2 PROGRAMMER'S MODEL

OVERVIEW

S3C2440A is developed using the advanced ARM920T core, which has been designed by Advanced RISC Machines, Ltd.

PROCESSOR OPERATING STATES

From the programmer's point of view, the ARM920T can be in one of the two states:

- ARM state which executes 32-bit, word-aligned ARM instructions
- THUMB state is a state which can execute 16-bit, halfword-aligned THUMB instructions. In this state, the PC uses bit 1 to select between alternate halfwords

NOTE

Transition between these two states does not affect the processor mode or the contents of the registers.

SWITCHING STATE

Entering THUMB State

Entry into THUMB state can be achieved by executing a BX instruction with the state bit (bit 0) set in the operand register.

Transition to THUMB state will also occur automatically on return from an exception (IRQ, FIQ, UNDEF, ABORT, SWI etc.), if the exception is entered with the processor in THUMB state.

Entering ARM State

Entry into ARM state can be done by the following methods:-

- On execution of the BX instruction with the state bit clear in the operand register.
- On the processor taking an exception (IRQ, FIQ, RESET, UNDEF, ABORT, SWI etc.). In this case, the PC is placed in the exception mode's link register, and execution commences at the exception's vector address.

MEMORY FORMATS

ARM920T views memory as a linear collection of bytes numbered upwards from zero. Bytes 0 to 3 hold the first stored word, bytes 4 to 7 the second and so on. ARM920T can treat words in memory as being stored either in Big-Endian or Little-Endian format.

BIG-ENDIAN FORMAT

In Big-Endian format, the most significant byte of a word is stored at the lowest numbered byte and the least significant byte at the highest numbered byte. Byte 0 of the memory system is therefore connected to data lines 31 through 24.

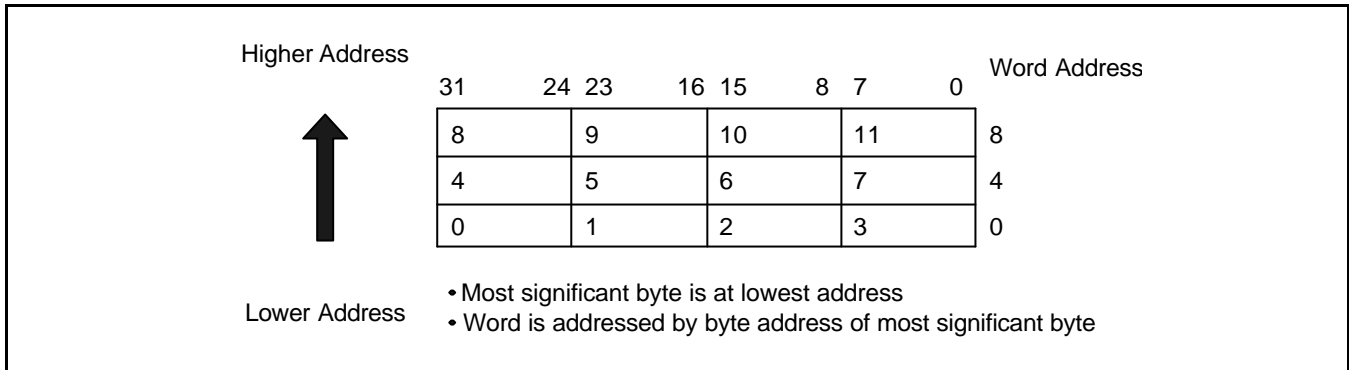

Figure 2-1. Big-Endian Addresses of Bytes within Words

LITTLE-ENDIAN FORMAT

In Little-Endian format, the lowest numbered byte in a word is considered the word's least significant byte, and the highest numbered byte the most significant. Byte 0 of the memory system is therefore connected to data lines 7 through 0.

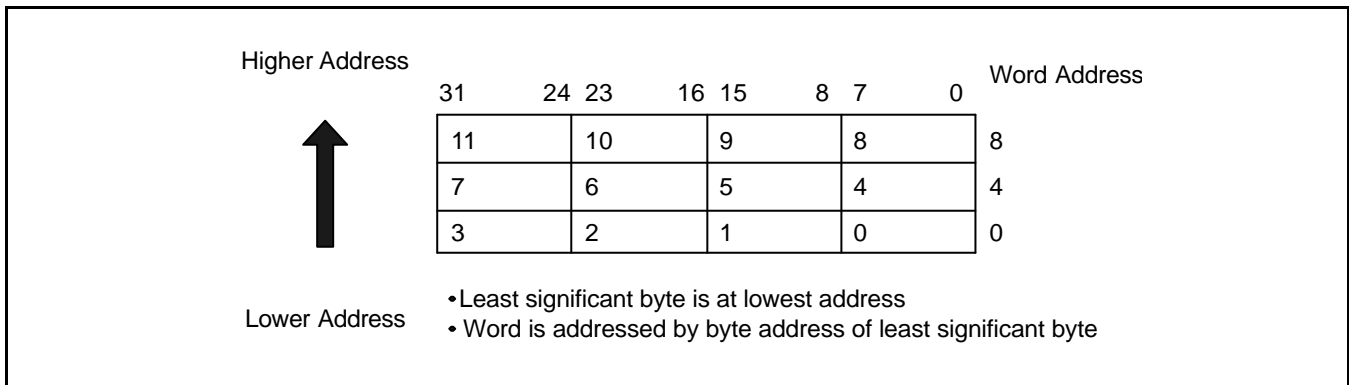

Figure 2-2. Little-Endian Addresses of Bytes within Words

INSTRUCTION LENGTH

Instructions are either 32 bits long (in ARM state) or 16 bits long (in THUMB state).

Data Types

ARM920T supports byte (8-bit), halfword (16-bit) and word (32-bit) data types. Words must be aligned to four-byte boundaries and half words to two-byte boundaries.

OPERATING MODES

ARM920T supports seven modes of operation:

- **User (usr):** The normal ARM program execution state
- **FIQ (fiq):** Designed to support a data transfer or channel process
- **IRQ (irq):** Used for general-purpose interrupt handling
- **Supervisor (svc):** Protected mode for the operating system
- **Abort mode (abt):** Entered after a data or instruction prefetch abort
- **System (sys):** A privileged user mode for the operating system
- **Undefined (und):** Entered when an undefined instruction is executed

Mode changes can be made using the control of software, or may be brought about by external interrupts or exception processing. Most application programs will execute in User mode. The non-user modes' known as privileged modes-are entered in order to service interrupts or exceptions, or to access protected resources.

REGISTERS

ARM920T has a total of 37 registers - 31 general-purpose 32-bit registers and six status registers - but these cannot all be seen at once. The processor state and operating mode decides which registers are available to the programmer.

The ARM State Register Set

In ARM state, 16 general registers and one or two status registers are visible at any one time. In privileged (non-User) modes, mode-specific banked registers are switched in. Figure 2-3 shows which register is available in each mode: the banked registers are marked with a shaded triangle.

The ARM state register set contains 16 directly accessible registers: R0 to R15. All of these except R15 are general-purpose, and may be used to hold either data or address values. In addition to these, there is a seventeenth register used to store status information.

Register 14	This register is used as the subroutine link register. This receives a copy of R15 when a Branch and Link (BL) instruction is executed. Rest of the time it may be treated as a general-purpose register. The corresponding banked registers R14_svc, R14_irq, R14_fiq, R14_abt and R14_und are similarly used to hold the return values of R15 when interrupts and exceptions arise, or when Branch and Link instructions are executed within interrupt or exception routines.
Register 15	This register holds the Program Counter (PC). In ARM state, bits [1:0] of R15 are zero and bits [31:2] contain the PC. In THUMB state, bit [0] is zero and bits [31:1] contain the PC.
Register 16	This register is the CPSR (Current Program Status Register). This contains condition code flags and the current mode bits.

FIQ mode has seven banked registers mapped to R8-14 (R8_fiq-R14_fiq). In ARM state there are many FIQ handlers which don't require saving registers. User, IRQ, Supervisor, Abort and Undefined, each have two banked registers mapped to R13 and R14, allowing each of these modes to have a private stack pointer and link registers.

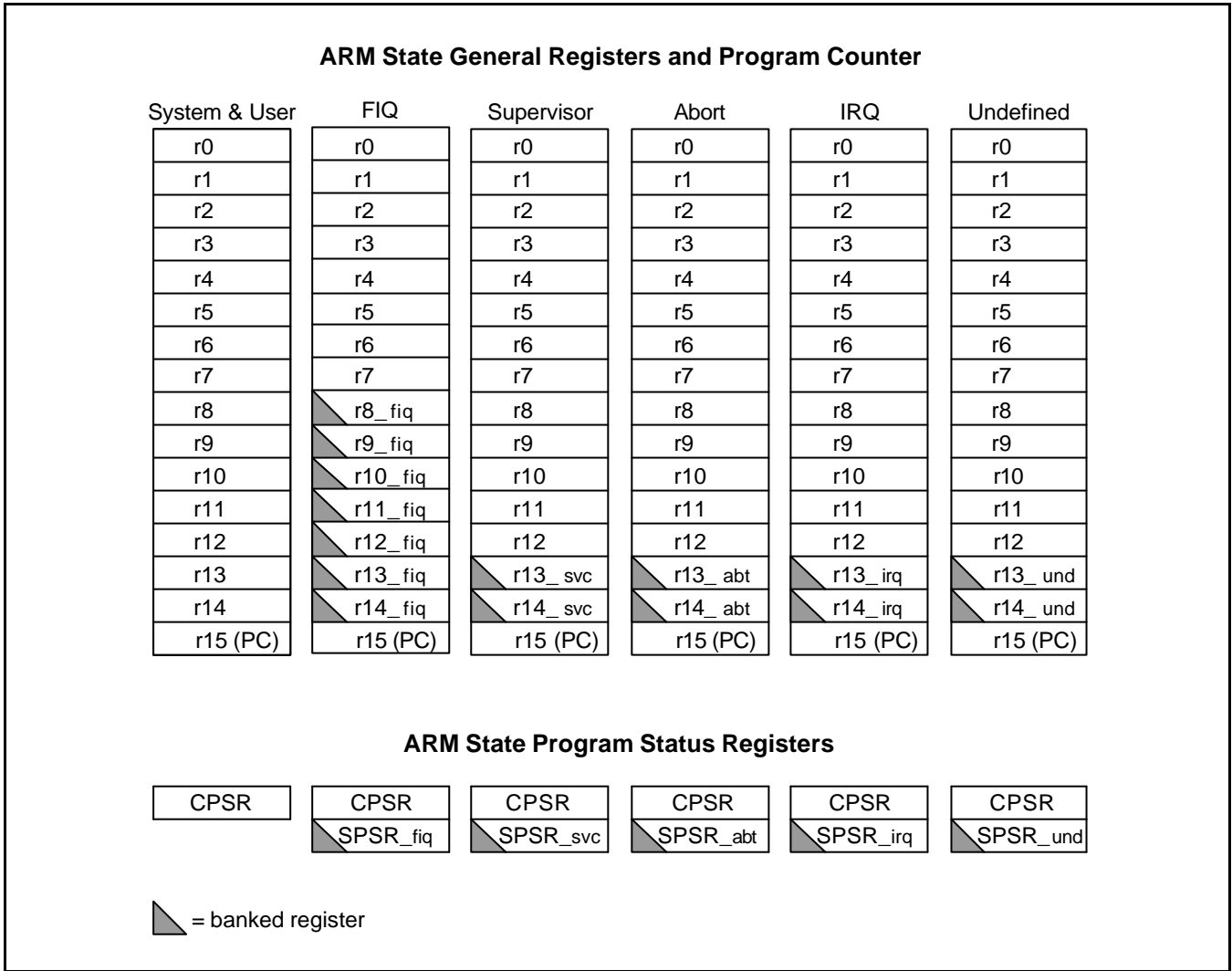

Figure 2-3. Register Organization in ARM State

The THUMB State Register Set

The THUMB state register set is a subset of the ARM state set. The programmer has direct access to eight general registers, R0-R7, as well as the Program Counter (PC), a stack pointer register (SP), a link register (LR), and the CPSR. There are banked Stack Pointers, Link Registers and Saved Process Status Registers (SPSRs) for each privileged mode. This is shown in Figure 2-4.

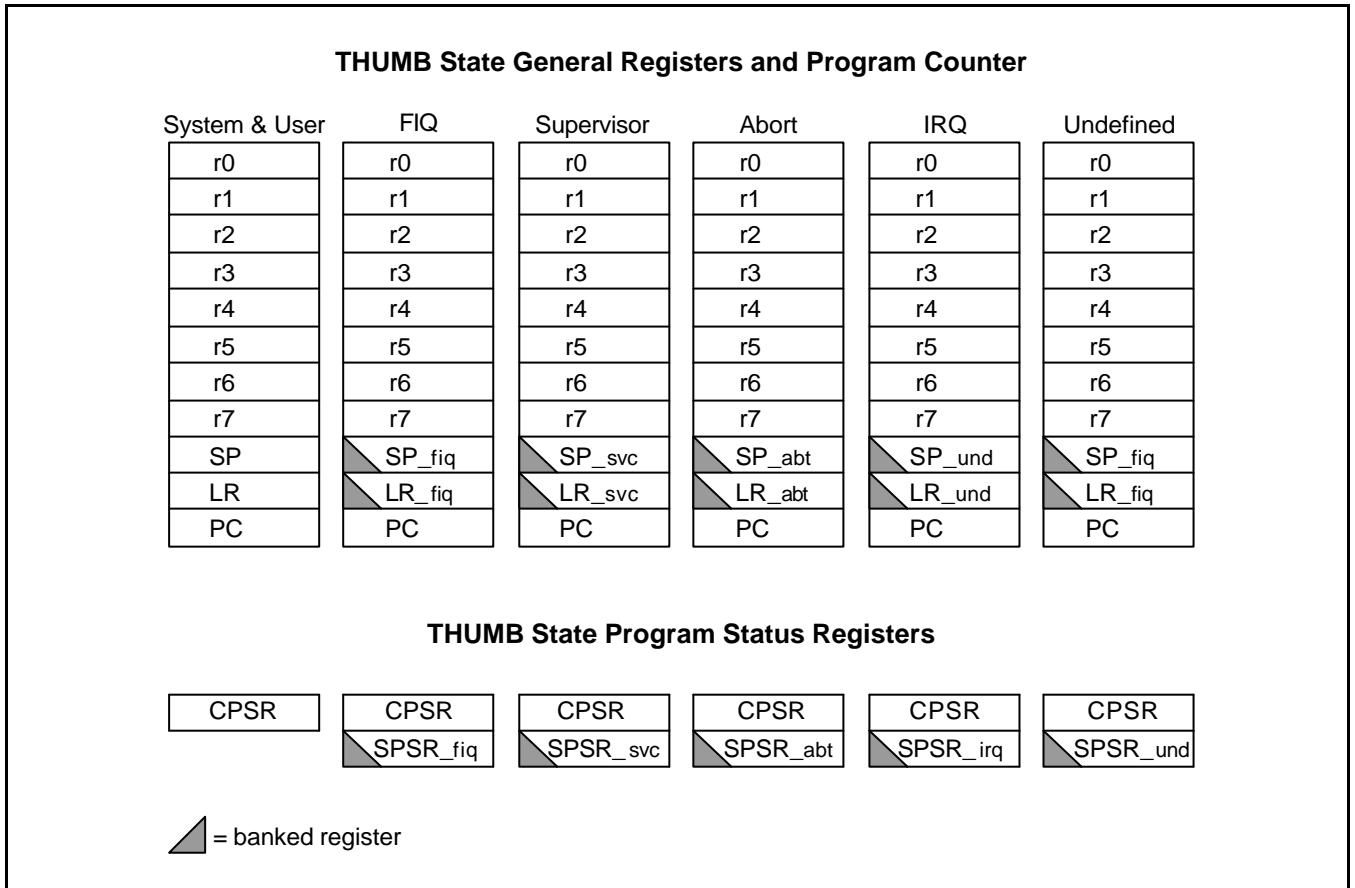

Figure 2-4. Register Organization in THUMB state

The relationship between ARM and THUMB state registers

The relationship between ARM and THUMB state registers are as below:-

- THUMB state R0-R7 and ARM state R0-R7 are identical
- THUMB state CPSR and SPSRs and ARM state CPSR and SPSRs are identical
- THUMB state SP maps onto ARM state R13
- THUMB state LR maps onto ARM state R14
- The THUMB state Program Counter maps onto the ARM state Program Counter (R15)

This relationship is shown in Figure 2-5.

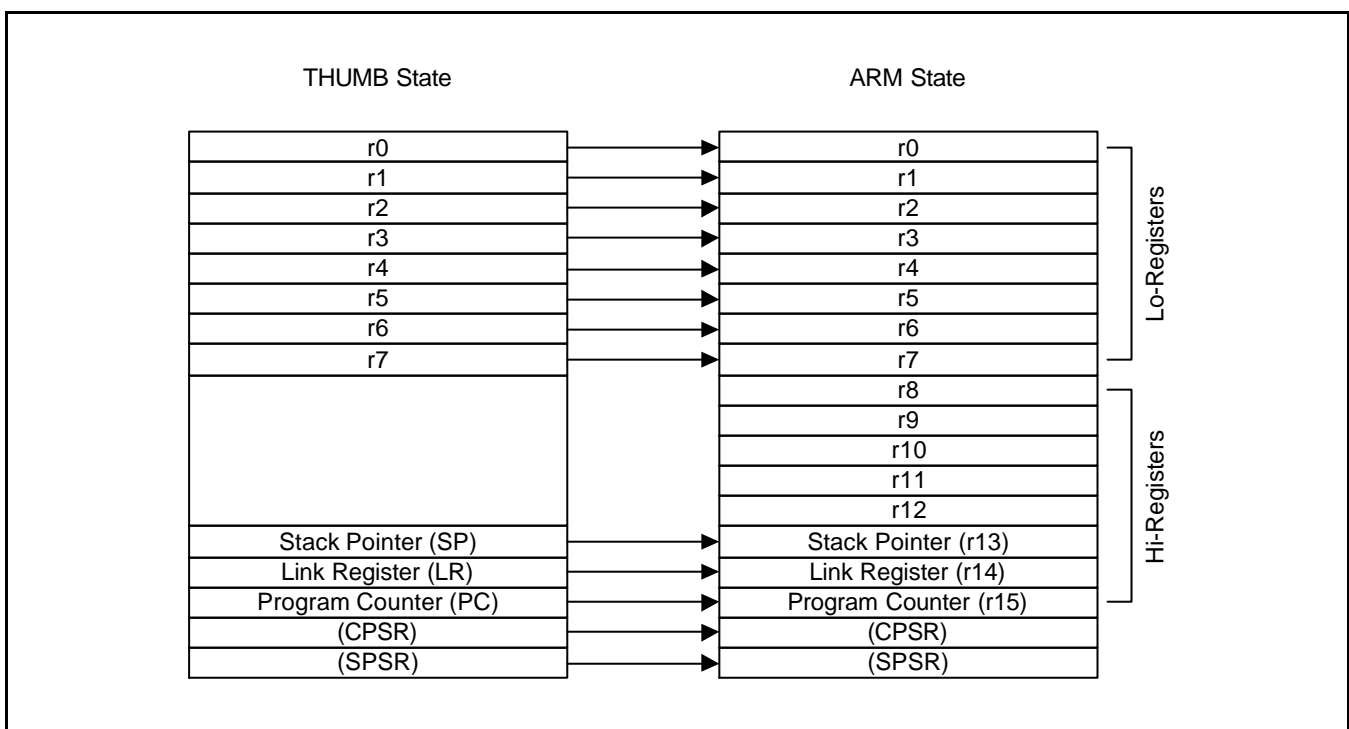

Figure 2-5. Mapping of THUMB State Registers onto ARM State Registers

Accessing Hi-Registers in THUMB State

In THUMB state, registers R8-R15 ("**Hi registers**") are not part of the standard register set. However, the assembly language programmer has limited access to them, and can use them for fast temporary storage.

A value may be transferred from a register in the range R0-R7 (a Lo register) to a Hi register and from a Hi register to a Lo register, using special variants of the MOV instruction. Hi register values can also be compared against or added to Lo register values with the CMP and ADD instructions. For more information, Please refer to Figure 3-34.

THE PROGRAM STATUS REGISTERS

The ARM920T contains a Current Program Status Register (CPSR), plus five Saved Program Status Registers (SPSRs) for use by exception handlers. These register's functions are:

- Hold information about the most recently performed ALU operation
- Control the enabling and disabling of interrupts
- Set the processor operating mode

The arrangement of bits is shown in Figure 2-6.

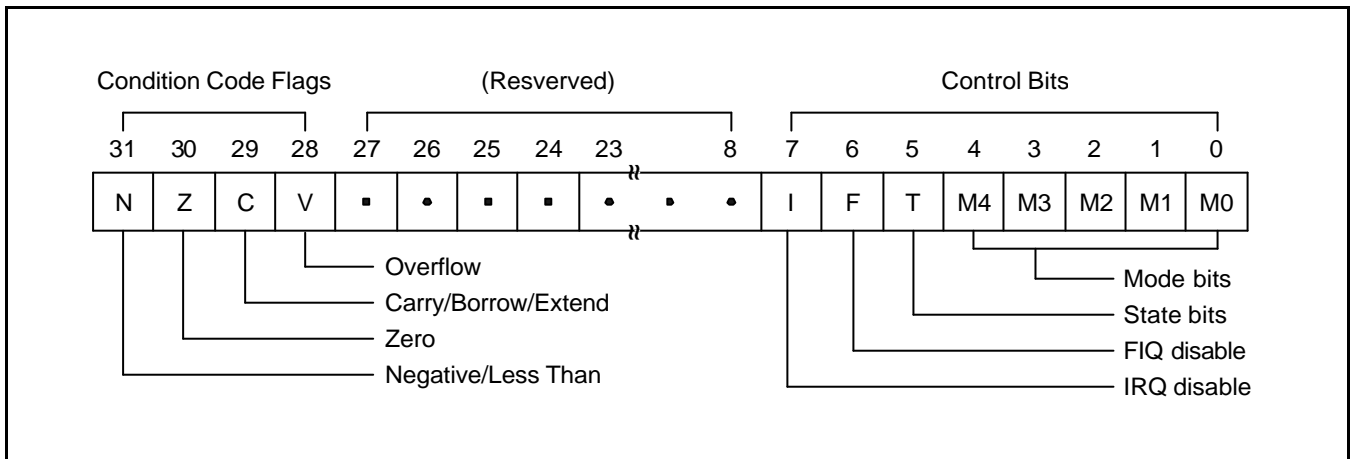

Figure 2-6. Program Status Register Format

The Condition Code Flags

The N, Z, C and V bits are the condition code flags. These may be changed as a result of arithmetic and logical operations, and may be tested to determine whether an instruction should be executed.

In ARM state, all instructions may be executed conditionally: see Table 3-2 for details.

In THUMB state, only the Branch instruction is capable of conditional execution: see Figure 3-46 for details.

The Control Bits

The bottom 8 bits of a PSR (incorporating I, F, T and M[4:0]) are known collectively as the control bits. These will be changed when an exception arises. If the processor is operating in a privileged mode, they can also be manipulated by software.

The T bit	This reflects the operating state. When this bit is set, the processor is executed in THUMB state, or otherwise it is executing in ARM state. This is reflected on the TBIT external signal. Note: That the software must never change the state of the TBIT in the CPSR. If this happens, the processor will enter an unpredictable state.
Interrupt disable bits	I and F bits are the interrupt disable bits. When set, these disable the IRQ and FIQ interrupts respectively.
The mode bits	The M4, M3, M2, M1 and M0 bits (M[4:0]) are the mode bits. These determine the processor's operating mode, as shown in Table 2-1. Not all combinations of the mode bits define a valid processor mode. Only those explicitly described shall be used. The user should be aware that if any illegal value is programmed into the mode bits, M[4:0], then the processor will enter an unrecoverable state. If this occurs, reset should be applied.
Reserved bits	The remaining bits in the PSRs are reserved. When changing a PSR's flag or control bits, you must ensure that these unused bits are not altered. Also, your program should not rely on them containing specific values, since in future processors they may read as one or zero.

Table 2-1. PSR Mode Bit Values

M[4:0]	Mode	Visible THUMB state registers	Visible ARM state registers
10000	User	R7..R0, LR, SP PC, CPSR	R14..R0, PC, CPSR
10001	FIQ	R7..R0, LR_fiq, SP_fiq PC, CPSR, SPSR_fiq	R7..R0, R14_fiq..R8_fiq, PC, CPSR, SPSR_fiq
10010	IRQ	R7..R0, LR_irq, SP_irq PC, CPSR, SPSR_irq	R12..R0, R14_irq, R13_irq, PC, CPSR, SPSR_irq
10011	Supervisor	R7..R0, LR_svc, SP_svc, PC, CPSR, SPSR_svc	R12..R0, R14_svc, R13_svc, PC, CPSR, SPSR_svc
10111	Abort	R7..R0, LR_abt, SP_abt, PC, CPSR, SPSR_abt	R12..R0, R14_abt, R13_abt, PC, CPSR, SPSR_abt
11011	Undefined	R7..R0 LR_und, SP_und, PC, CPSR, SPSR_und	R12..R0, R14_und, R13_und, PC, CPSR
11111	System	R7..R0, LR, SP PC, CPSR	R14..R0, PC, CPSR

Reserved bits

The remaining bits in the PSR's are reserved. While changing a PSR's flag or control bits, you must ensure that these unused bits are not altered. Also, your program should not rely on them containing specific values, since in future processors they may read as one or zero.

EXCEPTIONS

Exceptions arise whenever the normal flow of a program has to be halted temporarily, for example to service an interrupt from a peripheral. Before an exception can be handled, the current processor state must be preserved so that the original program can resume when the handler routine has finished.

It is possible for several exceptions to arise at the same time. If this happens, they are dealt with in a fixed order. See Exception Priorities on page 2-14.

Action on Entering an Exception

While handling an exception, the ARM920T does following activities:

1. Preserves the address of the next instruction in the appropriate Link Register. If the exception has been entered from ARM state, then the address of the next instruction is copied into the Link Register (that is, current PC + 4 or PC + 8 depending on the exception. See Table 2-2 on for details). If the exception has been entered from THUMB state, then the value written into the Link Register is the current PC offset by a value such that the program resumes from the correct place on return from the exception. This means that the exception handler need not determine which state the exception was entered from. For example, in the case of SWI, MOVS PC, R14_svc will always return to the next instruction regardless of whether the SWI was executed in ARM or THUMB state.
2. Copies the CPSR into the appropriate SPSR
3. Forces the CPSR mode bits to a value which depends on the exception
4. Forces the PC to fetch the next instruction from the relevant exception vector

It may also set the interrupt disable flags to prevent otherwise unmanageable nestings of exceptions.

If the processor is in THUMB state when an exception occurs, it will automatically switch into ARM state when the PC is loaded with the exception vector address.

Action on Leaving an Exception

On completion, the exception handler:

1. Moves the Link Register, minus an offset where appropriate, to the PC. (The offset will vary depending on the type of exception.)
2. Copies the SPSR back to the CPSR
3. Clears the interrupt disable flags, if they were set on entry

NOTE

An explicit switch back to THUMB state is never needed, since restoring the CPSR from the SPSR automatically sets the T bit to the value it held immediately prior to the exception.

Exception Entry/Exit Summary

Table 2-2 summarizes the PC value preserved in the relevant R14 on exception entry, and the recommended instruction for exiting the exception handler.

Table 2-2. Exception Entry/Exit

Return Instruction		Previous State		Notes
		ARM R14_x	THUMB R14_x	
BL	MOV PC, R14	PC + 4	PC + 2	(1)
SWI	MOVS PC, R14_svc	PC + 4	PC + 2	(1)
UDEF	MOVS PC, R14_und	PC + 4	PC + 2	(1)
FIQ	SUBS PC, R14_fiq, #4	PC + 4	PC + 4	(2)
IRQ	SUBS PC, R14_irq, #4	PC + 4	PC + 4	(2)
PABT	SUBS PC, R14_abt, #4	PC + 4	PC + 4	(1)
DABT	SUBS PC, R14_abt, #8	PC + 8	PC + 8	(3)
RESET	NA	–	–	(4)

NOTES:

1. Where PC is the address of the BL/SWI/Undefined Instruction fetch which had the prefetch abort.
2. Where PC is the address of the instruction which did not get executed since the FIQ or IRQ took priority.
3. Where PC is the address of the Load or Store instruction which generated the data abort.
4. The value saved in R14_svc upon reset is unpredictable.

FIQ

The **FIQ (Fast Interrupt Request)** exception is designed to support a data transfer or channel process, and in ARM state has sufficient private registers to remove the need for register saving (thus minimizing the overhead of context switching).

FIQ is externally generated by taking the nFIQ input LOW. This input can except either synchronous or asynchronous transitions, depending on the state of the ISYNC input signal. When ISYNC is LOW, nFIQ and nIRQ are considered asynchronous, and a cycle delay for synchronization is incurred before the interrupt can affect the processor flow.

Irrespective of whether the exception was entered from ARM or Thumb state, a FIQ handler should leave the interrupt by executing

```
SUBS    PC,R14_fiq,#4
```

FIQ may be disabled by setting the CPSR's F flag (but note that this is not possible from User mode). If the F flag is clear, ARM920T checks for a LOW level on the output of the FIQ synchronizer at the end of each instruction.

IRQ

The **IRQ (Interrupt Request)** exception is a normal interrupt caused by a LOW level on the nIRQ input. IRQ has a lower priority than FIQ and is masked out when a FIQ sequence is entered. It may be disabled at any time by setting I bit in the CPSR, though this can only be done from a privileged (non-User) mode.

Irrespective of whether the exception was entered from ARM or Thumb state, an IRQ handler should return from the interrupt by executing

```
SUBS    PC,R14_irq,#4
```

Abort

An abort indicates that the current memory access cannot be completed. It can be signaled by the external ABORT input. ARM920T checks for the abort exception during memory access cycles.

There are two types of abort:

- **Prefetch Abort:** occurs during an instruction prefetch.
- **Data Abort:** occurs during a data access.

If a prefetch abort occurs, the prefetched instruction is marked as invalid, but the exception will not be taken until the instruction reaches the head of the pipeline. If the instruction is not executed – the abort doesn't take place because a branch occurs while it is in the pipeline -.

If a data abort occurs, the action taken depends on the instruction type:

- Single data transfer instructions (LDR, STR) write back modified base registers: the Abort handler must be aware of this.
- The swap instruction (SWP) is aborted as though it had not been executed.
- Block data transfer instructions (LDM, STM) complete. If write-back is set, the base is updated. If the instruction would have overwritten the base with data (ie it has the base in the transfer list), the overwriting is prevented. All register overwriting is prevented after an abort is indicated, which means in particular that R15 (always the last register to be transferred) is preserved in an aborted LDM instruction.

The abort mechanism allows the implementation of a demand paged virtual memory system. In such a system the processor is allowed to generate arbitrary addresses. When the data at an address is unavailable, the Memory Management Unit (MMU) signals an abort. The abort handler must then work out the cause of the abort, make the requested data available, and retry the aborted instruction. The application program needs no knowledge of the amount of memory available to it, nor is its state in any way affected by the abort.

After fixing the reason for the abort, the handler should execute the following irrespective of the state (ARM or Thumb):

```
SUBS    PC,R14_abt,#4      ; for a prefetch abort, or
SUBS    PC,R14_abt,#8      ; for a data abort
```

This restores both the PC and the CPSR, and retries the aborted instruction.

Software Interrupt

The Software Interrupt Instruction (SWI) is used for entering Supervisor mode, usually to request a particular supervisor function. A SWI handler should return by executing the following irrespective of the state (ARM or Thumb):

```
MOV    PC,R14_svc
```

This restores the PC and CPSR, and returns to the instruction following the SWI.

NOTE

nFIQ, nIRQ, ISYNC, LOCK, BIGEND, and ABORT pins exist only in the ARM920T CPU core.

Undefined Instruction

When ARM920T comes across an instruction which cannot be handled, it takes the undefined instruction trap. This mechanism may be used to extend either the THUMB or ARM instruction set by software emulation.

After emulating the failed instruction, the trap handler should execute the following irrespective of the state (ARM or Thumb):

```
MOVS   PC,R14_und
```

This restores the CPSR and returns to the instruction following the undefined instruction.

Exception Vectors

The following table shows the exception vector addresses.

Table 2-3. Exception Vectors

Address	Exception	Mode in Entry
0x00000000	Reset	Supervisor
0x00000004	Undefined instruction	Undefined
0x00000008	Software Interrupt	Supervisor
0x0000000C	Abort (prefetch)	Abort
0x00000010	Abort (data)	Abort
0x00000014	Reserved	Reserved
0x00000018	IRQ	IRQ
0x0000001C	FIQ	FIQ

Exception Priorities

When multiple exceptions arise at the same time, a fixed priority system determines the order in which they are handled:

Highest priority:

1. Reset
2. Data abort
3. FIQ
4. IRQ
5. Prefetch abort

Lowest priority:

6. Undefined Instruction, Software interrupt.

Not All Exceptions Can Occur at Once:

Undefined Instruction and Software Interrupt are mutually exclusive, since they each correspond to particular (non-overlapping) decodings of the current instruction.

If a data abort occurs at the same time as a FIQ, and FIQs are enabled (ie the CPSR's F flag is clear), ARM920T enters the data abort handler and then immediately proceeds to the FIQ vector. A normal return from FIQ will cause the data abort handler to resume execution. Placing data abort at a higher priority than FIQ is necessary to ensure that the transfer error does not escape detection. The time for this exception entry should be added to worst-case FIQ latency calculations.

INTERRUPT LATENCIES

The worst case latency for FIQ, assuming that it is enabled, consists of the longest time the request can take to pass through the synchronizer ($T_{syncmax}$ if asynchronous), plus the time for the longest instruction to complete (T_{ldm} , the longest instruction is an LDM which loads all the registers including the PC), plus the time for the data abort entry (T_{exc}), plus the time for FIQ entry (T_{fiq}). At the end of this time ARM920T will be executing the instruction at 0x1C.

$T_{syncmax}$ is 3 processor cycles, T_{ldm} is 20 cycles, T_{exc} is 3 cycles, and T_{fiq} is 2 cycles. The total time is therefore 28 processor cycles. This is just over 1.4 microseconds in a system which uses a continuous 20 MHz processor clock. The maximum IRQ latency calculation is similar, but must allow for the fact that FIQ has higher priority and could delay entry into the IRQ handling routine for an arbitrary length of time. The minimum latency for FIQ or IRQ consists of the shortest time the request can take through the synchronizer ($T_{syncmin}$) plus T_{fiq} . This is 4 processor cycles.

RESET

When the nRESET signal goes LOW, ARM920T abandons the executing instruction and then continues to fetch instructions from incrementing word addresses.

When nRESET goes HIGH again, ARM920T:

1. Overwrites R14_svc and SPSR_svc by copying the current values of the PC and CPSR into them. The value of the saved PC and SPSR is not defined.
2. Forces M[4:0] to 10011 (Supervisor mode), sets the I and F bits in the CPSR, and clears the CPSR's T bit.
3. Forces the PC to fetch the next instruction from address 0x00.
4. Execution resumes in ARM state.

NOTES

3 ARM INSTRUCTION SET

INSTRUCTION SET SUMMARY

This chapter describes the ARM instruction set in the ARM920T core.

FORMAT SUMMARY

The following figure shows the ARM instruction set.

0 1 2 3 4 5 6 7 8 9 10 11 12 13 14 15 16 17 18 19 20 21 22 23 24 25 26 27 28 29 30 31																																	
Cond	0	0	1	Opcode				S	Rn				Rd				Operand2								Data/Processing/ PSR Transfer								
Cond	0	0	0	0	0	0	0	A	S	Rd				Rn				Rs	1	0	0	1	Rm				Multiply						
Cond	0	0	0	0	0	0	1	U	A	S	RdHi				RdLo				Rn				1	0	0	1	Rm				Multiply Long		
Cond	0	0	0	1	0	0	0	B	0	0	Rn				Rd				0	0	0	0	1	0	0	1	Rm				Single Data Swap		
Cond	0	0	0	1	0	0	1	0	1	1	1	1	1	1	1	1	1	1	1	1	1	1	0	0	0	1	Rn				Branch and Exchange		
Cond	0	0	0	P	U	0	W	L	Rn				Rd				0	0	0	0	1	S	H	1	Rm				Halfword Data Transfer: register offset				
Cond	0	0	0	P	U	1	W	L	Rn				Rd				Offset				1	S	H	1	Offset				Halfword Data Transfer: immediate offset				
Cond	0	1	1	P	U	B	W	L	Rn				Rd				Offset								Single Data Transfer								
Cond	0	1	1	1																								1					Undefined
Cond	1	0	0	P	U	B	W	L	Rn				Register List																Block Data Transfer				
Cond	1	0	1	L	Offset																										Branch		
Cond	1	1	0	P	U	B	W	L	Rn				CRd	CP#	Offset								Coprocessor Data Transfer										
Cond	1	1	1	0	CP Opc				CRn				CRd	CP#	CP	0	CRm				Coprocessor Data Operation												
Cond	1	1	1	0	CP	Opc	L	CRn				Rd	CP#	CP	1	CRm				Coprocessor Register Transfer													
Cond	1	1	1	1	Ignored by processor																										Software Interrupt		
0 1 2 3 4 5 6 7 8 9 10 11 12 13 14 15 16 17 18 19 20 21 22 23 24 25 26 27 28 29 30 31																																	

Figure 3-1. ARM Instruction Set Format

NOTES

Some instruction codes are not defined but does not cause Undefined instruction trap to be taken, for instance a multiply instruction with bit 6 changed to a 1. These instructions should not be used, as their action may change in future ARM implementations.

INSTRUCTION SUMMARY

Table 3-1. The ARM Instruction Set

Mnemonic	Instruction	Action
ADC	Add with carry	Rd: = Rn + Op2 + Carry
ADD	Add	Rd: = Rn + Op2
AND	AND	Rd: = Rn AND Op2
B	Branch	R15: = address
BIC	Bit clear	Rd: = Rn AND NOT Op2
BL	Branch with link	R14: = R15, R15: = address
BX	Branch and exchange	R15: = Rn, T bit: = Rn[0]
CDP	Coprocessor data processing	(Coprocessor-specific)
CMN	Compare Negative	CPSR flags: = Rn + Op2
CMP	Compare	CPSR flags: = Rn - Op2
EOR	Exclusive OR	Rd: = (Rn AND NOT Op2) OR (Op2 AND NOT Rn)
LDC	Load coprocessor from memory	Coprocessor load
LDM	Load multiple registers	Stack manipulation (Pop)
LDR	Load register from memory	Rd: = (address)
MCR	Move CPU register to coprocessor register	cRn: = rRn {<op>cRm}
MLA	Multiply accumulate	Rd: = (Rm × Rs) + Rn
MOV	Move register or constant	Rd: = Op2

Table 3-1. The ARM Instruction Set (Continued)

Mnemonic	Instruction	Action
MRC	Move from coprocessor register to CPU register	$Rn = cRn \{<op>cRm\}$
MRS	Move PSR status/flags to register	$Rn = PSR$
MSR	Move register to PSR status/flags	$PSR = Rm$
MUL	Multiply	$Rd = Rm \times Rs$
MVN	Move negative register	$Rd = 0 \times \text{FFFFFFFF EOR Op2}$
ORR	OR	$Rd = Rn \text{ OR Op2}$
RSB	Reverse subtract	$Rd = Op2 - Rn$
RSC	Reverse subtract with Carry	$Rd = Op2 - Rn - 1 + \text{Carry}$
SBC	Subtract with Carry	$Rd = Rn - Op2 - 1 + \text{Carry}$
STC	Store coprocessor register to memory	$\text{address} = CRn$
STM	Store Multiple	Stack manipulation (Push)
STR	Store register to memory	$<\text{address}> = Rd$
SUB	Subtract	$Rd = Rn - Op2$
SWI	Software Interrupt	OS call
SWP	Swap register with memory	$Rd = [Rn], [Rn] := Rm$
TEQ	Test bitwise equality	$CPSR \text{ flags} = Rn \text{ EOR Op2}$
TST	Test bits	$CPSR \text{ flags} = Rn \text{ AND Op2}$

THE CONDITION FIELD

In ARM state, all instructions are conditionally executed according to the state of the CPSR condition codes and the instruction's condition field. This field (bits 31:28) determines the circumstances under which an instruction is to be executed. If the state of the C, N, Z and V flags fulfils the conditions encoded by the field, the instruction is executed, otherwise it is ignored.

There are sixteen possible conditions, each represented by a two-character suffix that can be appended to the instruction's mnemonic. For example, a Branch (B in assembly language) becomes BEQ for "Branch if Equal", which means the Branch will only be taken if the Z flag is set.

In practice, fifteen different conditions may be used: these are listed in Table 3-2. The sixteenth (1111) is reserved, and must not be used.

In the absence of a suffix, the condition field for most instructions is set to "Always" (suffix AL). This means the instruction will always be executed regardless of the CPSR condition codes.

Table 3-2. Condition Code Summary

Code	Suffix	Flags	Meaning
0000	EQ	Z set	equal
0001	NE	Z clear	not equal
0010	CS	C set	unsigned higher or same
0011	CC	C clear	unsigned lower
0100	MI	N set	negative
0101	PL	N clear	positive or zero
0110	VS	V set	overflow
0111	VC	V clear	no overflow
1000	HI	C set and Z clear	unsigned higher
1001	LS	C clear or Z set	unsigned lower or same
1010	GE	N equals V	greater or equal
1011	LT	N not equal to V	less than
1100	GT	Z clear AND (N equals V)	greater than
1101	LE	Z set OR (N not equal to V)	less than or equal
1110	AL	(ignored)	always

BRANCH AND EXCHANGE (BX)

This instruction is only executed if the condition is true. The various conditions are defined in Table 3-2.

This instruction performs a branch by copying the contents of a general register, Rn, into the Program Counter, PC. The branch causes a pipeline flush and refill from the address specified by Rn. This instruction also permits the instruction set to be exchanged. When the instruction is executed, the value of Rn[0] determines whether the instruction stream will be decoded as ARM or THUMB instructions.

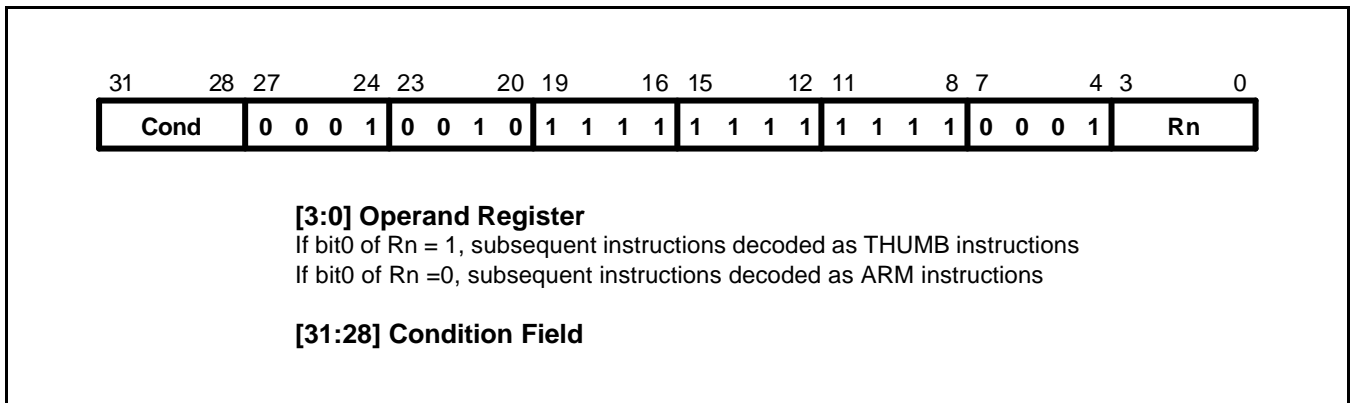

Figure 3-2. Branch and Exchange Instructions

INSTRUCTION CYCLE TIMES

The BX instruction takes $2S + 1N$ cycles to execute, where S and N are defined as sequential (S-cycle) and non-sequential (N-cycle), respectively.

ASSEMBLER SYNTAX

BX - branch and exchange.

BX {cond} Rn

{cond} Two character condition mnemonic. See Table 3-2.

Rn is an expression evaluating to a valid register number.

USING R15 AS AN OPERAND

If R15 is used as an operand, the behavior is undefined.

Examples

ADR R0, Into_THUMB + 1	Generate branch target address and set bit 0 high – hence it comes in THUMB state
BX R0	Branch and change to THUMB state.
CODE16	Assemble subsequent code as
Into_THUMB	THUMB instructions
ADR R5, Back_to_ARM	Generate branch target to word aligned address hence bit 0 is low and so change back to ARM state.
BX R5	Branch and change back to ARM state.
ALIGN	Word alignment
CODE32	Assemble subsequent code as ARM instructions
Back_to_ARM	–

ASSEMBLER SYNTAX

Items in “{}” are optional. Items in “<>” must be present.

B{L}{cond} <expression>

{L}	Used to request the Branch with Link form of the instruction. If absent, R14 will not be affected by the instruction.
{cond}	A two-character mnemonic as shown in Table 3-2. If absent then AL (ALways) will be used.
<expression>	The destination. The assembler calculates the offset

Examples

```

here      BAL      here      ; Assembles to 0xEAFFFFF0 (note effect of PC offset).
          B        there     ; Always condition used as default.
          CMP      R1,#0     ; Compare R1 with zero and branch to fred
                                     if R1 was zero, otherwise continue.
          BEQ      fred      ; Continue to next instruction.
          BL       sub+ROM    ; Call subroutine at computed address.
          ADDS    R1,#1     ; Add 1 to register 1, setting CPSR flags
                                     on the result then call subroutine if
          BLCC    sub        ; the C flag is clear, which will be the
                                     case unless R1 held 0xFFFFFFFF.

```

The instruction produces a result by performing a specified arithmetic or logical operation on one or two operands. The first operand is always a register (Rn).

The second operand may be a shifted register (Rm) or a rotated 8 bit immediate value (Imm) according to the value of the I bit in the instruction. The condition codes in the CPSR may be preserved or updated as a result of this instruction, according to the value of the S bit in the instruction.

Certain operations (TST, TEQ, CMP, CMN) do not write the result to Rd. They are used only to perform tests and to set the condition codes on the result and always have the S bit set. The instructions and their effects are listed in Table 3-3.

CPSR FLAGS

The data processing operations can be classified as logical or arithmetic. The logical operations (AND, EOR, TST, TEQ, ORR, MOV, BIC, MVN) perform the logical action on all corresponding bits of the operand or operands to produce the result. If the S bit is set (and Rd is not R15, see below) the V flag in the CPSR will be unaffected. The C flag will be set to the carry out from the barrel shifter (or preserved when the shift operation is LSL #0), the Z flag will be set if and only if the result is all zeros, and the N flag will be set to the logical value of bit 31 of the result.

Table 3-3. ARM Data Processing Instructions

Assembler Mnemonic	OP Code	Action
AND	0000	Operand1 AND operand2
EOR	0001	Operand1 EOR operand2
WUB	0010	Operand1 - operand2
RSB	0011	Operand2 operand1
ADD	0100	Operand1 + operand2
ADC	0101	Operand1 + operand2 + carry
SBC	0110	Operand1 - operand2 + carry - 1
RSC	0111	Operand2 - operand1 + carry - 1
TST	1000	As AND, but result is not written
TEQ	1001	As EOR, but result is not written
CMP	1010	As SUB, but result is not written
CMN	1011	As ADD, but result is not written
ORR	1100	Operand1 OR operand2
MOV	1101	Operand2 (operand1 is ignored)
BIC	1110	Operand1 AND NOT operand2 (Bit clear)
MVN	1111	NOT operand2 (operand1 is ignored)

The arithmetic operations (SUB, RSB, ADD, ADC, SBC, RSC, CMP, CMN) treat each operand as a 32 bit integer (either unsigned or 2's complement signed, the two are equivalent). If the S bit is set (and Rd is not R15) the V flag in the CPSR will be set if an overflow occurs into bit 31 of the result; this may be ignored if the operands were considered unsigned, but warns of a possible error if the operands were 2's complement signed. The C flag will be set to the carry out of bit 31 of the ALU, the Z flag will be set if and only if the result was zero, and the N flag will be set to the value of bit 31 of the result (indicating a negative result if the operands are considered to be 2's complement signed).

SHIFTS

When the second operand is specified to be a shifted register, the operation of the barrel shifter is controlled by the Shift field in the instruction. This field indicates the type of shift to be performed (logical left or right, arithmetic right or rotate right). The amount by which the register should be shifted may contain an immediate field in the instruction, or in the bottom byte of another register (other than R15). The encoding for the different shift types is shown in Figure 3-5.

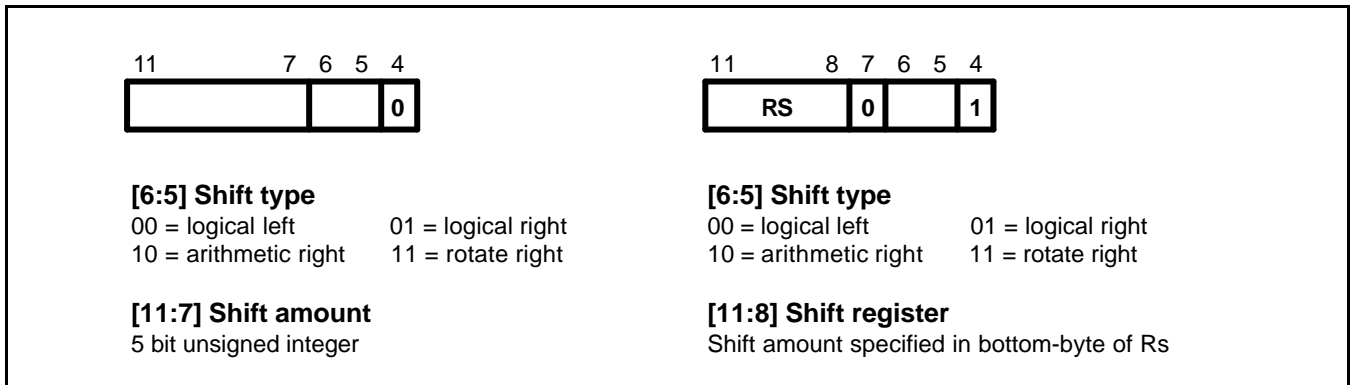

Figure 3-5. ARM Shift Operations

Instruction specified shift amount

When the shift amount is specified in the instruction, it is contained in a 5 bit field which can take any value from 0 to 31. A **Logical Shift Left (LSL)** takes the contents of Rm and moves each bit by the specified amount to a more significant position. The least significant bits of the result are filled with zeros, and the high bits of Rm which do not map into the result are discarded, except that the least significant discarded bit becomes the shifter carry output which may be latched into the C bit of the CPSR when the ALU operation is in the logical class (see above). For example, the effect of LSL #5 is shown in Figure 3-6.

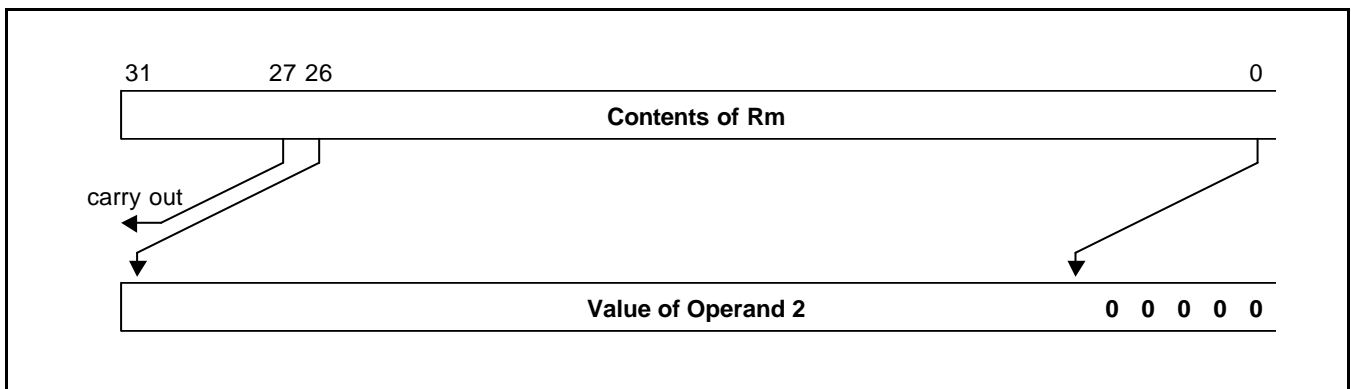

Figure 3-6. Logical Shift Left

NOTE

LSL #0 is a special case, where the shifter carry out is the old value of the CPSR C flag. The contents of Rm are used directly as the second operand. A **Logical Shift Right (LSR)** is similar, but the contents of Rm are moved to less significant positions in the result. LSR #5 has the effect shown in Figure 3-7.

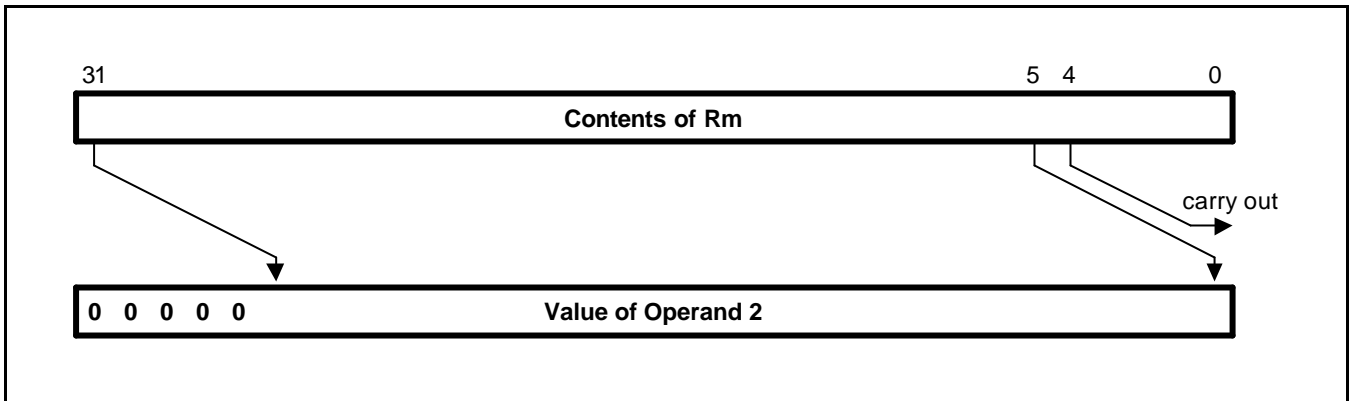

Figure 3-7. Logical Shift Right

The form of the shift field which might be expected to correspond to LSR #0 is used to encode LSR #32, which has a zero result with bit 31 of Rm as the carry output. Logical shift right zero is redundant as it is the same as logical shift left zero, so the assembler will convert LSR #0 (and ASR #0 and ROR #0) into LSL #0, and allow LSR #32 to be specified.

An **Arithmetic Shift Right (ASR)** is similar to logical shift right, except that the high bits are filled with bit 31 of Rm instead of zeros. This preserves the sign in 2's complement notation. For example, ASR #5 is shown in Figure 3-8.

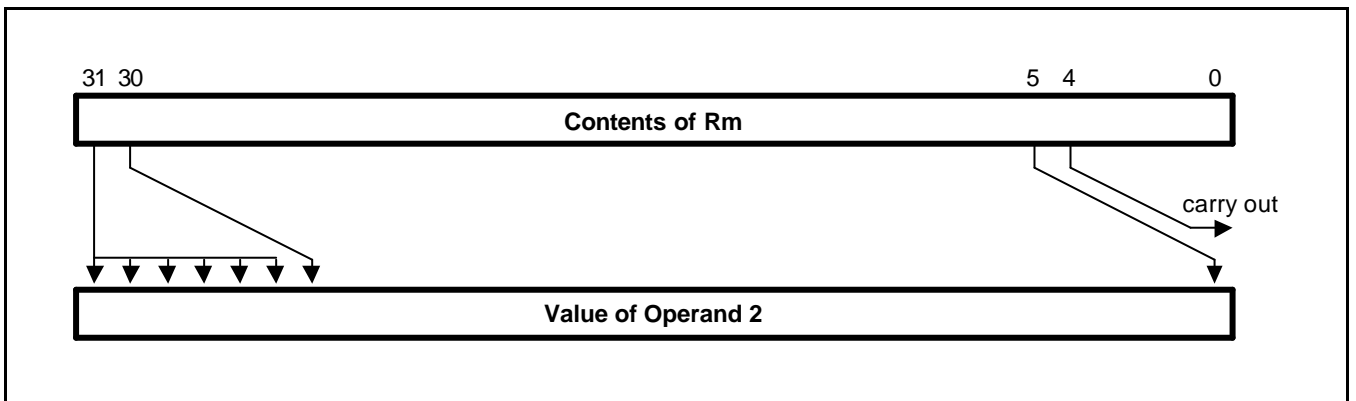

Figure 3-8. Arithmetic Shift Right

The form of the shift field which might be expected to give ASR #0 is used to encode ASR #32. Bit 31 of Rm is again used as the carry output, and each bit of operand 2 is also equal to bit 31 of Rm. The result is therefore all ones or all zeros, according to the value of bit 31 of Rm.

Rotate right (ROR) operations reuse the bits which "overshoot" in a logical shift right operation by reintroducing them at the high end of the result, in place of the zeros used to fill the high end in logical right operations. For example, ROR #5 is shown in Figure 3-9.

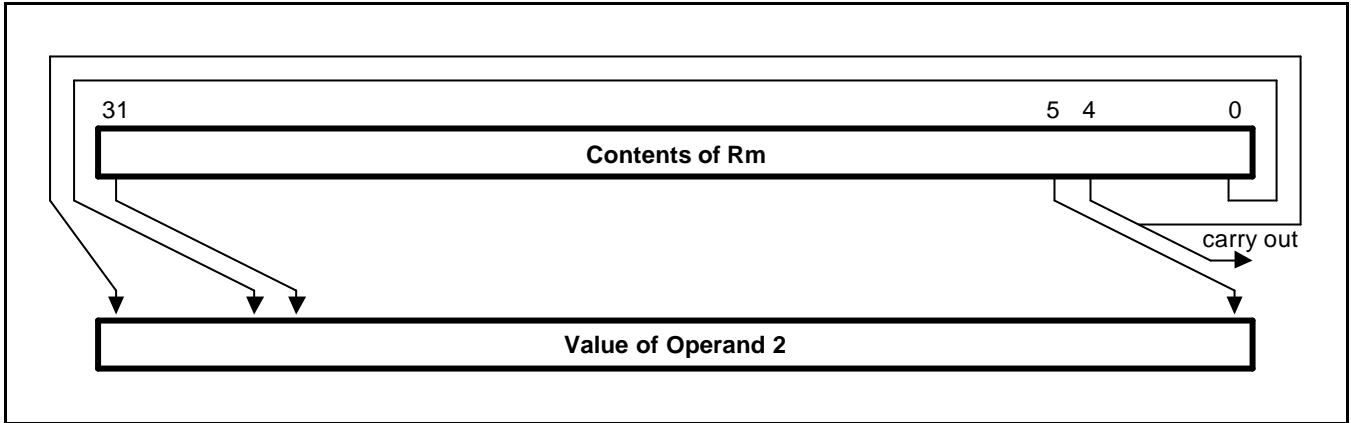

Figure 3-9. Rotate Right

The form of the shift field which might be expected to give ROR #0 is used to encode a special function of the barrel shifter, rotate right extended (RRX). This is a rotate right by one bit position of the 33 bit quantity formed by appending the CPSR C flag to the most significant end of the contents of Rm as shown in Figure 3-10.

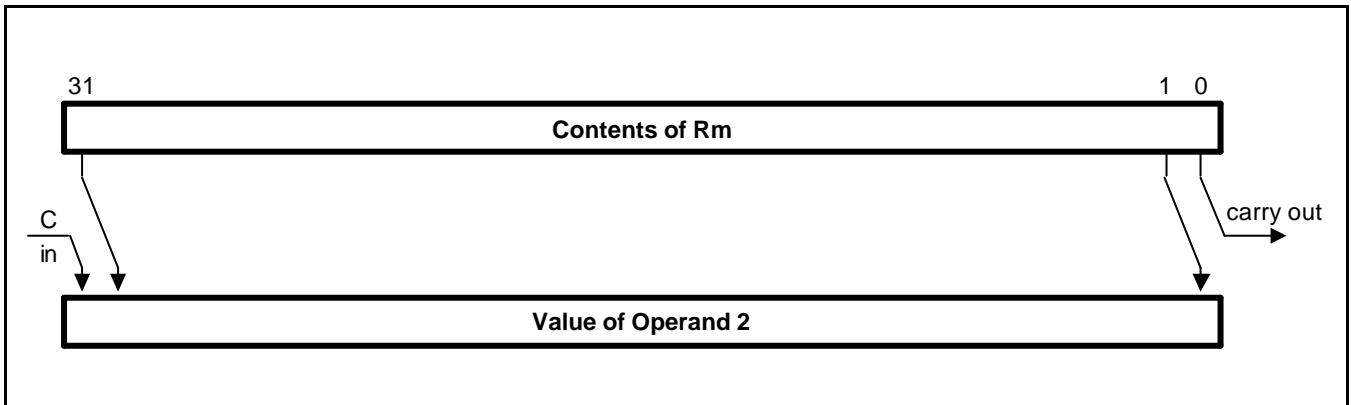

Figure 3-10. Rotate Right Extended

Register Specified Shift Amount

Only the least significant byte of the contents of Rs is used to determine the shift amount. Rs can be any general register other than R15.

If this byte is zero, the unchanged contents of Rm will be used as the second operand, and the old value of the CPSR C flag will be passed on as the shifter carry output.

If the byte has a value between 1 and 31, the shifted result will exactly match that of an instruction specified shift with the same value and shift operation.

If the value in the byte is 32 or more, the result will be a logical extension of the shift described above:

1. LSL by 32 has result zero, carry out equal to bit 0 of Rm.
2. LSL by more than 32 has result zero, carry out zero.
3. LSR by 32 has result zero, carry out equal to bit 31 of Rm.
4. LSR by more than 32 has result zero, carry out zero.
5. ASR by 32 or more has result filled with and carry out equal to bit 31 of Rm.
6. ROR by 32 has result equal to Rm, carry out equal to bit 31 of Rm.
7. ROR by n where n is greater than 32 will give the same result and carry out as ROR by n-32; therefore repeatedly subtract 32 from n until the amount is in the range 1 to 32 and see above.

NOTE

The zero in bit 7 of an instruction with a register controlled shift is compulsory; a one in this bit will cause the instruction to be a multiply or undefined instruction.

IMMEDIATE OPERAND ROTATES

The immediate operand rotate field is a 4 bit unsigned integer which specifies a shift operation on the 8 bit immediate value. This value is zero extended to 32 bits, and then subject to a rotate right by twice the value in the rotate field. This enables many common constants to be generated, for example all powers of 2.

WRITING TO R15

When Rd is a register other than R15, the condition code flags in the CPSR may be updated from the ALU flags as described above.

When Rd is R15 and the S flag in the instruction is not set the result of the operation is placed in R15 and the CPSR is unaffected.

When Rd is R15 and the S flag is set the result of the operation is placed in R15 and the SPSR corresponding to the current mode is moved to the CPSR. This allows state changes which automatically restore both PC and CPSR. This form of instruction should not be used in User mode.

USING R15 AS AN OPERANDY

If R15 (the PC) is used as an operand in a data processing instruction the register is used directly.

The PC value will be the address of the instruction, plus 8 or 12 bytes due to instruction prefetching. If the shift amount is specified in the instruction, the PC will be 8 bytes ahead. If a register is used to specify the shift amount the PC will be 12 bytes ahead.

TEQ, TST, CMP AND CMN OPCODES

NOTE

TEQ, TST, CMP and CMN do not write the result of their operation but do set flags in the CPSR. An assembler should always set the S flag for these instructions even if this is not specified in the mnemonic.

The TEQP form of the TEQ instruction used in earlier ARM processors must not be used: the PSR transfer operations should be used instead.

The action of TEQP in the ARM920T is to move SPSR_<mode> to the CPSR if the processor is in a privileged mode and to do nothing if in User mode.

INSTRUCTION CYCLE TIMES

Data Processing instructions vary in the number of incremental cycles taken as follows:

Table 3-4. Incremental Cycle Times

Processing Type	Cycles
Normal data processing	1S
Data processing with register specified shift	1S + 1I
Data processing with PC written	2S + 1N
Data processing with register specified shift and PC written	2S + 1N + 1I

NOTE: S, N and I are as defined sequential (S-cycle), non-sequential (N-cycle), and internal (I-cycle) respectively.

ASSEMBLER SYNTAX

- MOV,MVN (single operand instructions).
<opcode>{cond}{S} Rd,<Op2>
- CMP,CMN,TEQ,TST (instructions which do not produce a result).
<opcode>{cond} Rn,<Op2>
- AND,EOR,SUB,RSB,ADD,ADC,SBC,RSC,ORR,BIC
<opcode>{cond}{S} Rd,Rn,<Op2>

where:

<Op2> Rm{,<shift>} or,<#expression>

{cond} A two-character condition mnemonic. See Table 3-2.

{S} Set condition codes if S present (implied for CMP, CMN, TEQ, TST).

Rd, Rn and Rm Expressions evaluating to a register number.

<#expression> If this is used, the assembler will attempt to generate a shifted immediate 8-bit field to match the expression. If this is impossible, it will give an error.

<shift> <Shiftname> <register> or <shiftname> #expression, or RRX (rotate right one bit with extend).

<shiftname>s ASL, LSL, LSR, ASR, ROR. (ASL is a synonym for LSL, they assemble to the same code.)

EXAMPLES

ADDEQ	R2,R4,R5	; If the Z flag is set make R2:=R4+R5
TEQS	R4,#3	; Test R4 for equality with 3.
		; (The S is in fact redundant as the
		; assembler inserts it automatically.)
SUB	R4,R5,R7,LSR R2	; Logical right shift R7 by the number in
		; the bottom byte of R2, subtract result
		; from R5, and put the answer into R4.
MOV	PC,R14	; Return from subroutine.
MOVS	PC,R14	; Return from exception and restore CPSR
		; from SPSR_mode.

PSR TRANSFER (MRS, MSR)

The instruction is only executed if the condition is true. The various conditions are defined in Table 3-2.

The MRS and MSR instructions are formed from a subset of the Data Processing operations and are implemented using the TEQ, TST, CMN and CMP instructions without the S flag set. The encoding is shown in Figure 3-11.

These instructions allow access to the CPSR and SPSR registers. The MRS instruction allows the contents of the CPSR or SPSR_<mode> to be moved to a general register. The MSR instruction allows the contents of a general register to be moved to the CPSR or SPSR_<mode> register.

The MSR instruction also allows an immediate value or register contents to be transferred to the condition code flags (N,Z,C and V) of CPSR or SPSR_<mode> without affecting the control bits. In this case, the top four bits of the specified register contents or 32 bit immediate value are written to the top four bits of the relevant PSR.

OPERAND RESTRICTIONS

- In user mode, the control bits of the CPSR are protected from change, so only the condition code flags of the CPSR can be changed. In other (privileged) modes the entire CPSR can be changed.
- Note that the software must never change the state of the T bit in the CPSR. If this happens, the processor will enter an unpredictable state.
- The SPSR register which is accessed depends on the mode at the time of execution. For example, only SPSR_fiq is accessible when the processor is in FIQ mode.
- You must not specify R15 as the source or destination register.
- Also, do not attempt to access an SPSR in User mode, since no such register exists.

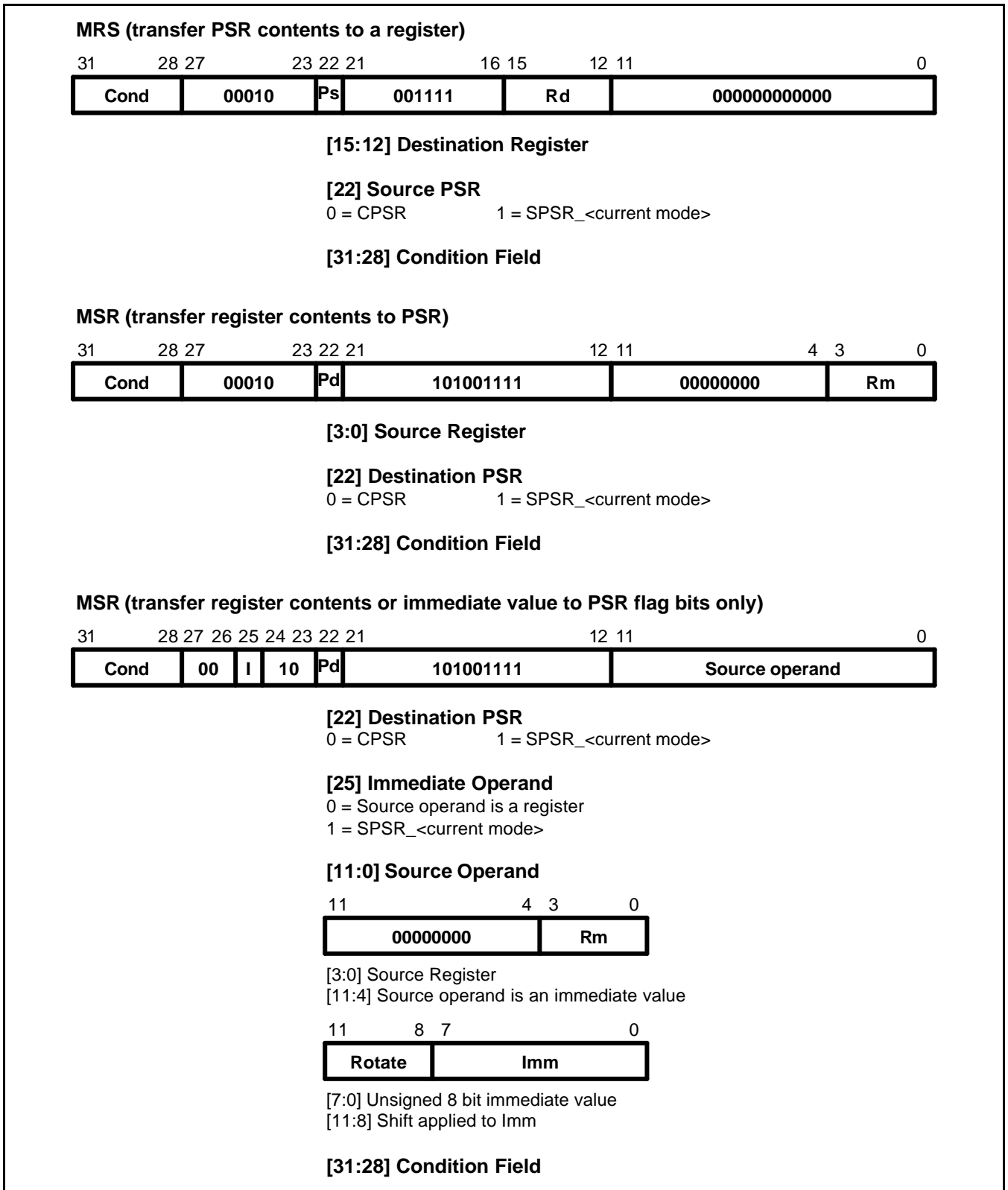

Figure 3-11. PSR Transfer

RESERVED BITS

Only twelve bits of the PSR are defined in ARM920T (N,Z,C,V,I,F, T & M[4:0]); the remaining bits are reserved for use in future versions of the processor. Refer to Figure 2-6 for a full description of the PSR bits.

To ensure the maximum compatibility between ARM920T programs and future processors, the following rules should be observed:

- The reserved bits should be preserved while changing the value in a PSR.
- Programs should not rely on specific values from the reserved bits while checking the PSR status, since they may read as one or zero in future processors.

A read-modify-write strategy should therefore be used when altering the control bits of any PSR register; this involves transferring the appropriate PSR register to a general register using the MRS instruction, changing only the relevant bits and then transferring the modified value back to the PSR register using the MSR instruction.

EXAMPLES

The following sequence performs a mode change:

```

MRS      R0,CPSR           ; Take a copy of the CPSR.
BIC      R0,R0,#0x1F      ; Clear the mode bits.
ORR      R0,R0,#new_mode  ; Select new mode
MSR      CPSR,R0          ; Write back the modified CPSR.

```

When the aim is simply to change the condition code flags in a PSR, a value can be written directly to the flag bits without disturbing the control bits. The following instruction sets the N,Z,C and V flags:

```

MSR      CPSR_flg,#0xF000000 ; Set all the flags regardless of their previous state
                                           ; (does not affect any control bits).

```

No attempt should be made to write an 8 bit immediate value into the whole PSR since such an operation cannot preserve the reserved bits.

INSTRUCTION CYCLE TIMES

PSR transfers take 1S incremental cycles, where S is defined as Sequential (S-cycle).

ASSEMBLY SYNTAX

- MRS - transfer PSR contents to a register
MRS{cond} Rd,<psr>
- MSR - transfer register contents to PSR
MSR{cond} <psr>,Rm
- MSR - transfer register contents to PSR flag bits only
MSR{cond} <psrf>,Rm

The most significant four bits of the register contents are written to the N,Z,C & V flags respectively.

- MSR - transfer immediate value to PSR flag bits only
MSR{cond} <psrf>,<#expression>

The expression should symbolise a 32 bit value of which the most significant four bits are written to the N,Z,C and V flags respectively.

Key:

{cond}	Two-character condition mnemonic. See Table 3-2..
Rd and Rm	Expressions evaluating to a register number other than R15
<psr>	CPSR, CPSR_all, SPSR or SPSR_all. (CPSR and CPSR_all are synonyms as are SPSR and SPSR_all)
<psrf>	CPSR_flg or SPSR_flg
<#expression>	Where this is used, the assembler will attempt to generate a shifted immediate 8-bit field to match the expression. If this is impossible, it will give an error.

EXAMPLES

In User mode the instructions behave as follows:

```

MSR    CPSR_all,Rm      ; CPSR[31:28] <- Rm[31:28]
MSR    CPSR_flg,Rm     ; CPSR[31:28] <- Rm[31:28]
MSR    CPSR_flg,#0xA0000000 ; CPSR[31:28] <- 0xA (set N,C; clear Z,V)
MRS    Rd,CPSR         ; Rd[31:0] <- CPSR[31:0]

```

In privileged modes the instructions behave as follows:

```

MSR    CPSR_all,Rm     ; CPSR[31:0] <- Rm[31:0]
MSR    CPSR_flg,Rm    ; CPSR[31:28] <- Rm[31:28]
MSR    CPSR_flg,#0x50000000 ; CPSR[31:28] <- 0x5 (set Z,V; clear N,C)
MSR    SPSR_all,Rm    ; SPSR_<mode>[31:0] <- Rm[31:0]
MSR    SPSR_flg,Rm   ; SPSR_<mode>[31:28] <- Rm[31:28]
MSR    SPSR_flg,#0xC0000000 ; SPSR_<mode>[31:28] <- 0xC (set N,Z; clear C,V)
MRS    Rd,SPSR       ; Rd[31:0] <- SPSR_<mode>[31:0]

```

MULTIPLY AND MULTIPLY-ACCUMULATE (MUL, MLA)

The instruction is only executed if the condition is true. The various conditions are defined in Table 3-2. The instruction encoding is shown in Figure 3-12.

The multiply and multiply-accumulate instructions use an 8 bit Booth's algorithm to perform integer multiplication.

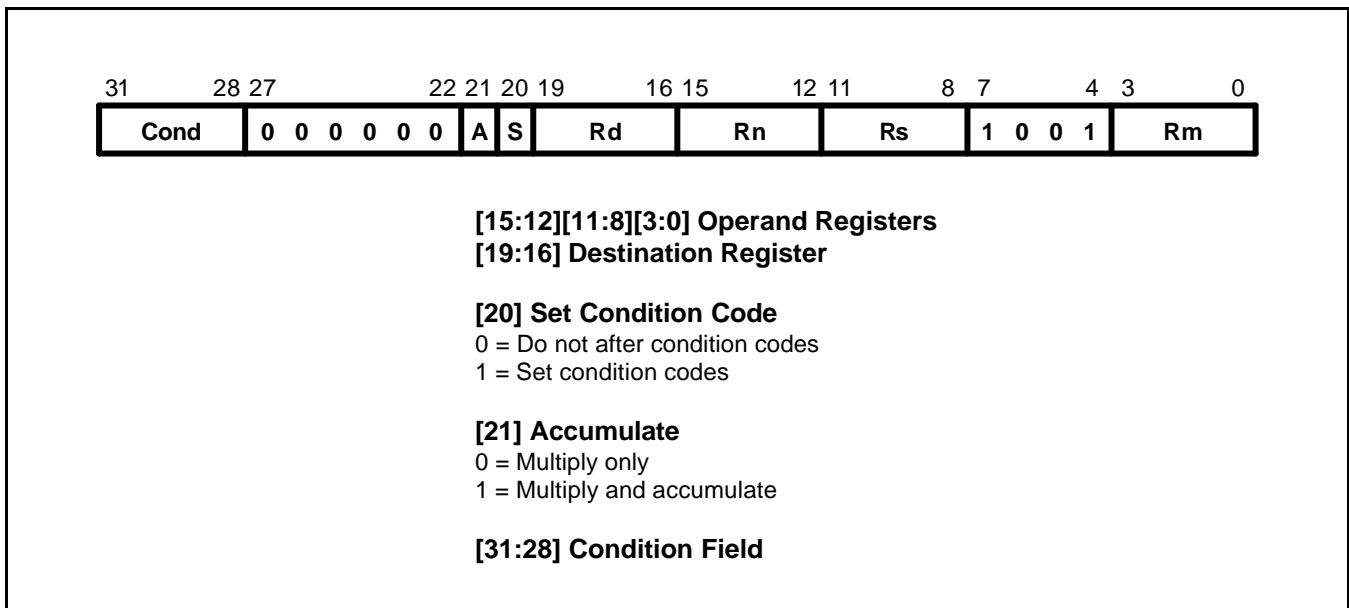

Figure 3-12. Multiply Instructions

The multiply form of the instruction gives $Rd := Rm * Rs$. Rn is ignored, and should be set to zero for compatibility with possible future upgrades to the instruction set. The multiply-accumulate form gives $Rd := Rm * Rs + Rn$, which can save an explicit ADD instruction in some circumstances. Both forms of the instruction work on operands which may be considered as signed (2's complement) or unsigned integers.

The results of a signed multiply and of an unsigned multiply of 32 bit operands differ only in the upper 32 bits - the low 32 bits of the signed and unsigned results are identical. As these instructions only produce the low 32 bits of a multiply, they can be used for both signed and unsigned multiplies.

For example consider the multiplication of the operands:

Operand A	Operand B	Result
0xFFFFFFFF6	0x0000001	0xFFFFFFFF38

If the Operands Are Interpreted as Signed

Operand A has the value -10, operand B has the value 20, and the result is -200 which is correctly represented as 0xFFFFFFFF38.

If the Operands Are Interpreted as Unsigned

Operand A has the value 4294967286, operand B has the value 20 and the result is 85899345720, which is represented as 0x13FFFFFF38, so the least significant 32 bits are 0xFFFFFFFF38.

Operand Restrictions

The destination register Rd must not be the same as the operand register Rm. R15 must not be used as an operand or as the destination register.

All other register combinations will give correct results, and Rd, Rn and Rs may use the same register when required.

CPSR FLAGS

Setting the CPSR flags is optional, and is controlled by the S bit in the instruction. The N (Negative) and Z (Zero) flags are set correctly on the result (N is made equal to bit 31 of the result, and Z is set if and only if the result is zero). The C (Carry) flag is set to a meaningless value and the V (oVerflow) flag is unaffected.

INSTRUCTION CYCLE TIMES

MUL takes $1S + mI$ and MLA $1S + (m+1)I$ cycles to execute, where S and I are defined as sequential (S-cycle) and internal (I-cycle), respectively.

m	The number of 8 bit multiplier array cycles is required to complete the multiply, which is controlled by the value of the multiplier operand specified by Rs. Its possible values are as follows
1	If bits [32:8] of the multiplier operand are all zero or all one.
2	If bits [32:16] of the multiplier operand are all zero or all one.
3	If bits [32:24] of the multiplier operand are all zero or all one.
4	In all other cases.

ASSEMBLER SYNTAX

MUL{cond}{S} Rd,Rm,Rs
MLA{cond}{S} Rd,Rm,Rs,Rn

{cond}	Two-character condition mnemonic. See Table 3-2..
{S}	Set condition codes if S present
Rd, Rm, Rs and Rn	Expressions evaluating to a register number other than R15.

EXAMPLES

```
MUL      R1,R2,R3          ; R1:=R2*R3
MLAEQS   R1,R2,R3,R4      ; Conditionally R1:=R2*R3+R4, Setting condition codes.
```

MULTIPLY LONG AND MULTIPLY-ACCUMULATE LONG (MULL, MLAL)

The instruction is only executed if the condition is true. The various conditions are defined in Table 3-2. The instruction encoding is shown in Figure 3-13.

The multiply long instructions perform integer multiplication on two 32 bit operands and produce 64 bit results. Signed and unsigned multiplication each with optional accumulate give rise to four variations.

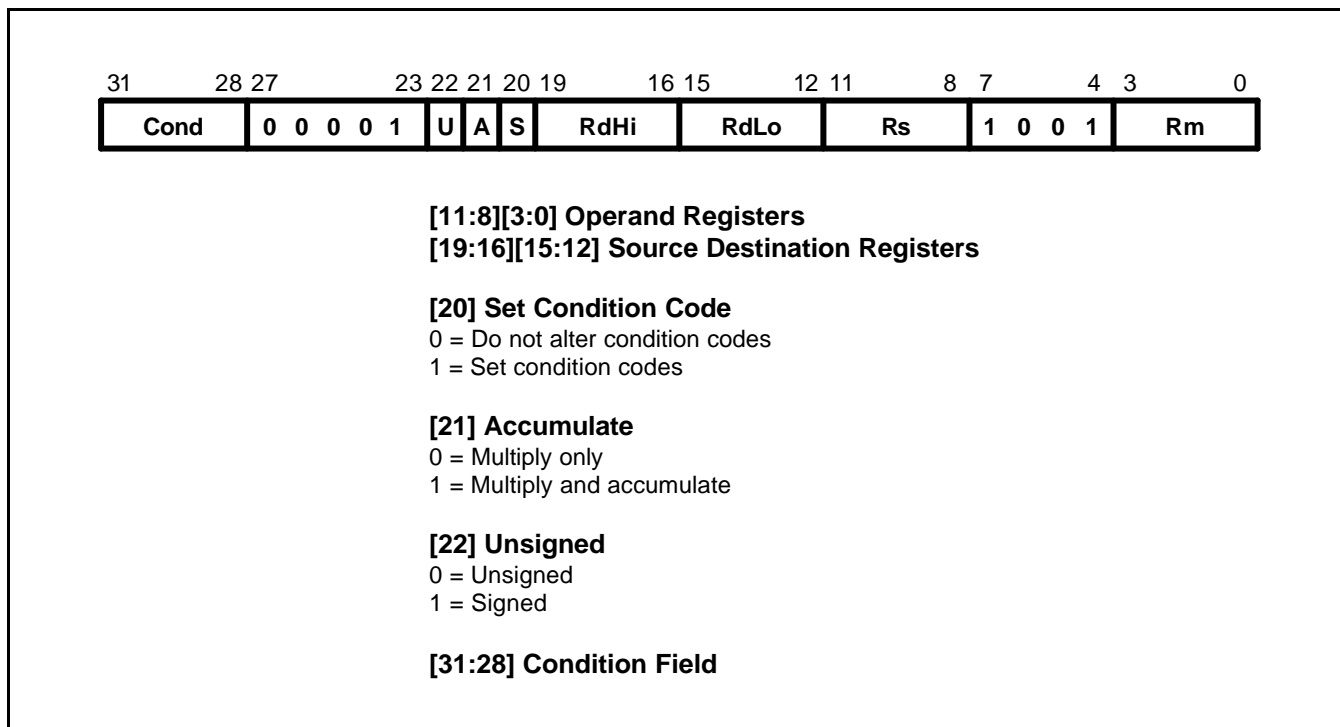

Figure 3-13. Multiply Long Instructions

The multiply forms (UMULL and SMULL) take two 32 bit numbers and multiply them to produce a 64 bit result of the form $RdHi, RdLo := Rm * Rs$. The lower 32 bits of the 64 bit result are written to RdLo, the upper 32 bits of the result are written to RdHi.

The multiply-accumulate forms (UMLAL and SMLAL) take two 32 bit numbers, multiply them and add a 64 bit number to produce a 64 bit result of the form $RdHi, RdLo := Rm * Rs + RdHi, RdLo$. The lower 32 bits of the 64 bit number to add is read from RdLo. The upper 32 bits of the 64 bit number to add is read from RdHi. The lower 32 bits of the 64 bit result are written to RdLo. The upper 32 bits of the 64 bit result are written to RdHi.

The UMULL and UMLAL instructions treat all of their operands as unsigned binary numbers and write an unsigned 64 bit result. The SMULL and SMLAL instructions treat all of their operands as two's-complement signed numbers and write a two's-complement signed 64 bit result.

OPERAND RESTRICTIONS

- R15 must not be used as an operand or as a destination register.
- RdHi, RdLo, and Rm must all specify different registers.

CPSR FLAGS

Setting the CPSR flags is optional, and is controlled by the S bit in the instruction. The N and Z flags are set correctly on the result (N is equal to bit 63 of the result, Z is set if and only if all 64 bits of the result are zero). Both the C and V flags are set to meaningless values.

INSTRUCTION CYCLE TIMES

MULL takes $1S + (m+1)I$ and MLAL $1S + (m+2)I$ cycles to execute, where m is the number of 8 bit multiplier array cycles required to complete the multiply, which is controlled by the value of the multiplier operand specified by Rs.

Its possible values are as follows:

For Signed INSTRUCTIONS SMULL, SMLAL:

- If bits [31:8] of the multiplier operand are all zero or all one.
- If bits [31:16] of the multiplier operand are all zero or all one.
- If bits [31:24] of the multiplier operand are all zero or all one.
- In all other cases.

For Unsigned Instructions UMULL, UMLAL:

- If bits [31:8] of the multiplier operand are all zero.
- If bits [31:16] of the multiplier operand are all zero.
- If bits [31:24] of the multiplier operand are all zero.
- In all other cases.

S and I are defined as sequential (S-cycle) and internal (I-cycle), respectively.

ASSEMBLER SYNTAX

Table 3-5. Assembler Syntax Descriptions

Mnemonic	Description	Purpose
UMULL{cond}{S} RdLo,RdHi,Rm,Rs	Unsigned Multiply Long	$32 \times 32 = 64$
UMLAL{cond}{S} RdLo,RdHi,Rm,Rs	Unsigned Multiply & Accumulate Long	$32 \times 32 + 64 = 64$
SMULL{cond}{S} RdLo,RdHi,Rm,Rs	Signed Multiply Long	$32 \times 32 = 64$
SMLAL{cond}{S} RdLo,RdHi,Rm,Rs	Signed Multiply & Accumulate Long	$32 \times 32 + 64 = 64$

where:

- {cond} Two-character condition mnemonic. See Table 3-2.
 {S} Set condition codes if S present
 RdLo, RdHi, Rm, Rs Expressions evaluating to a register number other than R15.

EXAMPLES

```

UMULL    R1,R4,R2,R3    ; R4,R1:=R2*R3
UMLALS   R1,R5,R2,R3    ; R5,R1:=R2*R3+R5,R1 also setting condition codes

```

SINGLE DATA TRANSFER (LDR, STR)

The instruction is only executed if the condition is true. The various conditions are defined in Table 3-2. The instruction encoding is shown in Figure 3-14.

The single data transfer instructions are used to load or store single bytes or words of data. The memory address used in the transfer is calculated by adding an offset to or subtracting an offset from a base register.

The result of this calculation may be written back into the base register if auto-indexing is required.

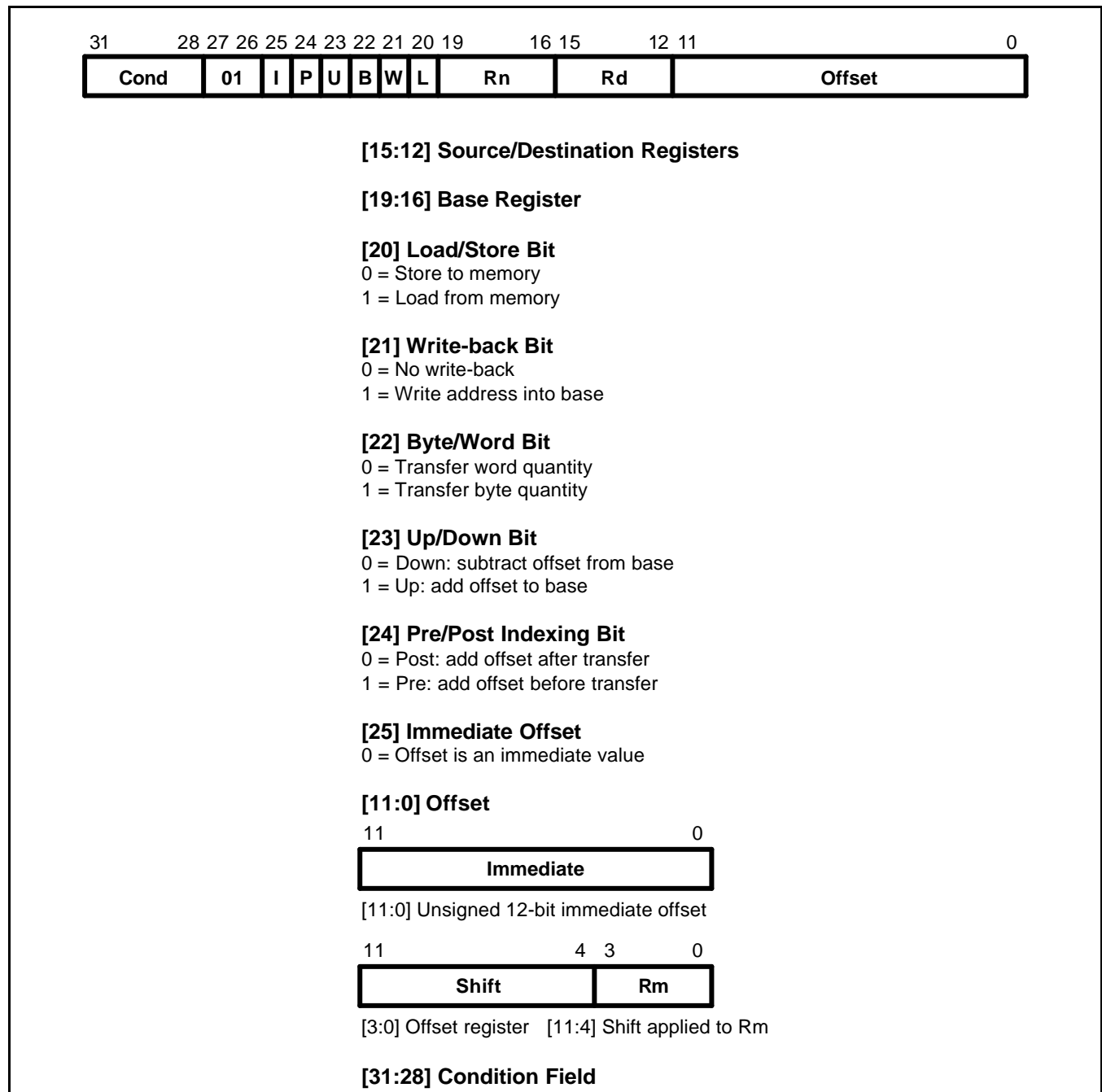

Figure 3-14. Single Data Transfer Instructions

OFFSETS AND AUTO-INDEXING

The offset from the base may be either a 12 bit unsigned binary immediate value in the instruction, or a second register (possibly shifted in some way). The offset may be added to (U=1) or subtracted from (U=0) the base register Rn. The offset modification may be performed either before (pre-indexed, P=1) or after (post-indexed, P=0) the base is used as the transfer address.

The W bit gives optional auto increment and decrement addressing modes. The modified base value may be written back into the base (W=1), or the old base value may be kept (W=0). In the case of post-indexed addressing, the write back bit is redundant and is always set to zero, since the old base value can be retained by setting the offset to zero. Therefore post-indexed data transfers always write back the modified base. The only use of the W bit in a post-indexed data transfer is in privileged mode code, where setting the W bit forces non-privileged mode for the transfer, allowing the operating system to generate a user address in a system where the memory management hardware makes suitable use of this hardware.

SHIFTED REGISTER OFFSET

The 8 shift control bits are described in the data processing instructions section. However, the register specified shift amounts are not available in this instruction class. See Figure 3-5.

BYTES AND WORDS

This instruction class may be used to transfer a byte (B=1) or a word (B=0) between an ARM920T register and memory.

The action of LDR(B) and STR(B) instructions is influenced by the **BIGEND** control signal of ARM920T core. The two possible configurations are described below.

Little-Endian Configuration

A byte load (LDRB) expects the data on data bus inputs 7 through 0 if the supplied address is on a word boundary, on data bus inputs 15 through 8, if it is a word address plus one byte, and so on. The selected byte is placed in the bottom 8 bits of the destination register, and the remaining bits of the register are filled with zeros. Please see Figure 2-2.

A byte store (STRB) repeats the bottom 8 bits of the source register four times across data bus outputs 31 through 0. The external memory system should activate the appropriate byte subsystem to store the data.

A word load (LDR) will normally use a word aligned address. However, an address offset from a word boundary will cause the data to be rotated into the register so that the addressed byte occupies bits 0 to 7. This means that half-words accessed at offsets 0 and 2 from the word boundary will be correctly loaded into bits 0 through 15 of the register. Two shift operations are then required to clear or to sign extend the upper 16 bits.

A word store (STR) should generate a word aligned address. The word presented to the data bus is not affected if the address is not word aligned. That is, bit 31 of the register being stored always appears on data bus output 31.

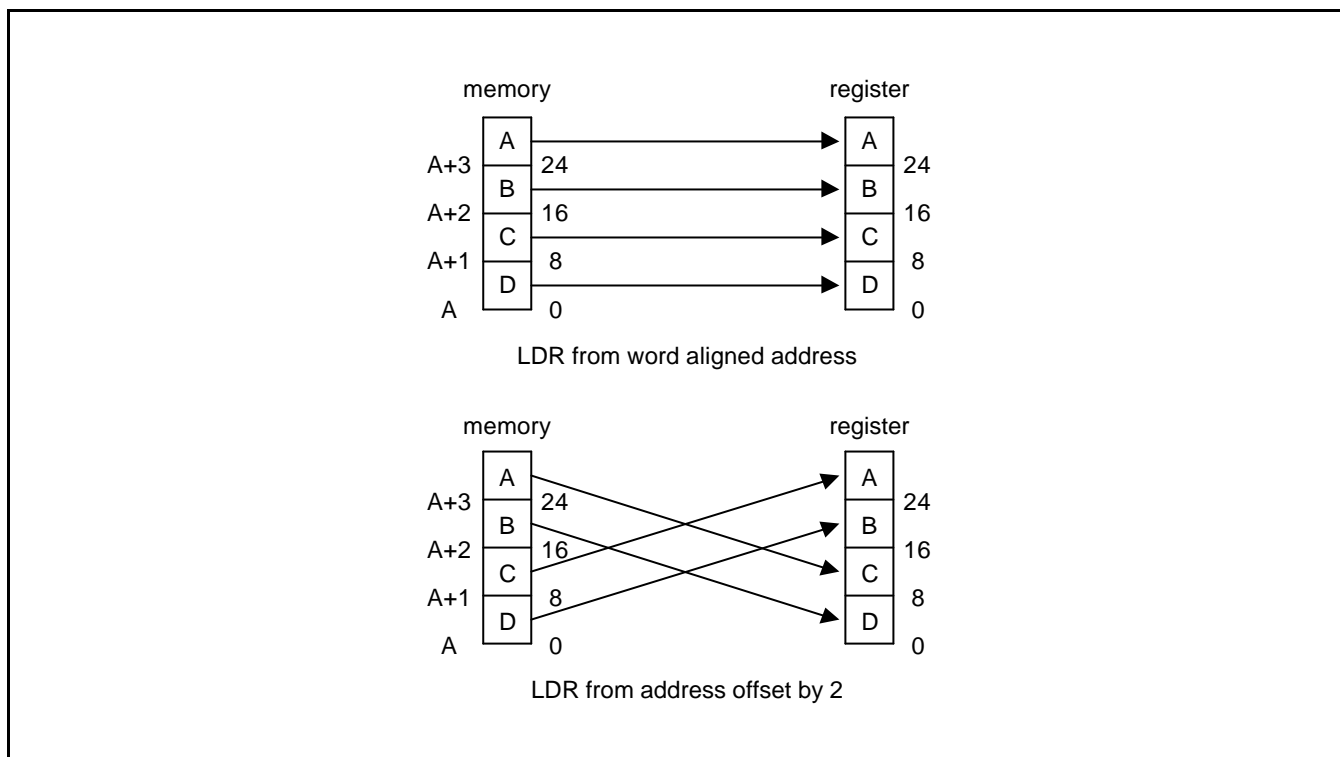

Figure 3-15. Little-Endian Offset Addressing

Big-Endian Configuration

A byte load (LDRB) expects the data on data bus inputs 31 through 24 if the supplied address is on a word boundary, on data bus inputs 23 through 16 if it is a word address plus one byte, and so on. The selected byte is placed in the bottom 8 bits of the destination register and the remaining bits of the register are filled with zeros. Please see Figure 2-1.

A byte store (STRB) repeats the bottom 8 bits of the source register four times across data bus outputs 31 through 0. The external memory system should activate the appropriate byte subsystem to store the data.

A word load (LDR) should generate a word aligned address. An address offset of 0 or 2 from a word boundary will cause the data to be rotated into the register so that the addressed byte occupies bits 31 through 24. This means that half-words accessed at these offsets will be correctly loaded into bits 16 through 31 of the register. A shift operation is then required to move (and optionally sign extend) the data into the bottom 16 bits. An address offset of 1 or 3 from a word boundary will cause the data to be rotated into the register so that the addressed byte occupies bits 15 through 8.

A word store (STR) should generate a word aligned address. The word presented to the data bus is not affected if the address is not word aligned. That is, bit 31 of the register being stored always appears on data bus output 31.

USE OF R15

Write-back must not be specified if R15 is specified as the base register (Rn). While using R15 as the base register, you must remember it contains an address of 8 bytes on from the address of the current instruction.

R15 must not be specified as the register offset (Rm).

When R15 is the source register (Rd) of a register store (STR) instruction, the stored value will be address of the instruction plus 12.

Restriction are made depending on the use of base register

When configured for late aborts, the following example code is difficult to unwind as the base register, Rn, gets updated before the abort handler starts. Sometimes it may be impossible to calculate the initial value.

After an abort, the following example code is difficult to unwind as the base register, Rn, gets updated before the abort handler starts. Sometimes it may be impossible to calculate the initial value.

EXAMPLE:

```
LDR    R0,[R1],R1
```

Therefore a post-indexed LDR or STR where Rm is the same register as Rn should not be used.

DATA ABORTS

A transfer to or from a legal address may cause problems for a memory management system. For instance, in a system which uses virtual memory the required data may be absent from main memory. The memory manager can signal a problem by taking the processor ABORT input HIGH whereupon the Data Abort trap will be taken. It is up to the system software to resolve the cause of the problem, then the instruction can be restarted and the original program continued.

INSTRUCTION CYCLE TIMES

Normal LDR instructions take $1S + 1N + 1I$ and LDR PC take $2S + 2N + 1I$ incremental cycles, where S,N and I are defined as sequential (S-cycle), non-sequential (N-cycle), and internal (I-cycle), respectively. STR instructions take $2N$ incremental cycles to execute.

ASSEMBLER SYNTAX

<LDR|STR>{cond}{B}{T} Rd,<Address>

where:

LDR	Load from memory into a register
STR	Store from a register into memory
{cond}	Two-character condition mnemonic. See Table 3-2.
{B}	If B is present then byte transfer, otherwise word transfer
{T}	If T is present the W bit will be set in a post-indexed instruction, forcing non-privileged mode for the transfer cycle. T is not allowed when a pre-indexed addressing mode is specified or implied.
Rd	An expression evaluating to a valid register number.
Rn and Rm	Expressions evaluating to a register number. If Rn is R15 then the assembler will subtract 8 from the offset value to allow for ARM920T pipelining. In this case base write-back should not be specified.
<Address>can be:	
1	An expression which generates an address: The assembler will attempt to generate an instruction using the PC as a base and a corrected immediate offset to address the location given by evaluating the expression. This will be a PC relative, pre-indexed address. If the address is out of range, an error will be generated.
2	A pre-indexed addressing specification: [Rn] offset of zero [Rn,<#expression>]{!} offset of <expression> bytes [Rn,{+/-}Rm{,<shift>}]!} offset of +/- contents of index register, shifted by <shift>
3	A post-indexed addressing specification: [Rn],<#expression> offset of <expression> bytes [Rn],{+/-}Rm{,<shift>} offset of +/- contents of index register, shifted as by <shift>.
<shift>	General shift operation (see data processing instructions) but you cannot specify the shift amount by a register.
{!}	Writes back the base register (set the W bit) if ! is present.

EXAMPLES

STR	R1,[R2,R4]!	; Store R1 at R2+R4 (both of which are registers)
		; and write back address to R2.
STR	R1,[R2],R4	; Store R1 at R2 and write back R2+R4 to R2.
LDR	R1,[R2,#16]	; Load R1 from contents of R2+16, but don't write back.
LDR	R1,[R2,R3,LSL#2]	; Load R1 from contents of R2+R3*4.
LDREQB	R1,[R6,#5]	; Conditionally load byte at R6+5 into
		; R1 bits 0 to 7, filling bits 8 to 31 with zeros.
STR	R1,PLACE	; Generate PC relative offset to address PLACE.
PLACE		

HALFWORD AND SIGNED DATA TRANSFER (LDRH/STRH/LDRSB/LDRSH)

The instruction is only executed if the condition is true. The various conditions are defined in Table 3-2. The instruction encoding is shown in Figure 3-16.

These instructions are used to load or store half-words of data and also load sign-extended bytes or half-words of data. The memory address used in the transfer is calculated by adding an offset to or subtracting an offset from a base register. The result of this calculation may be written back into the base register if auto-indexing is required.

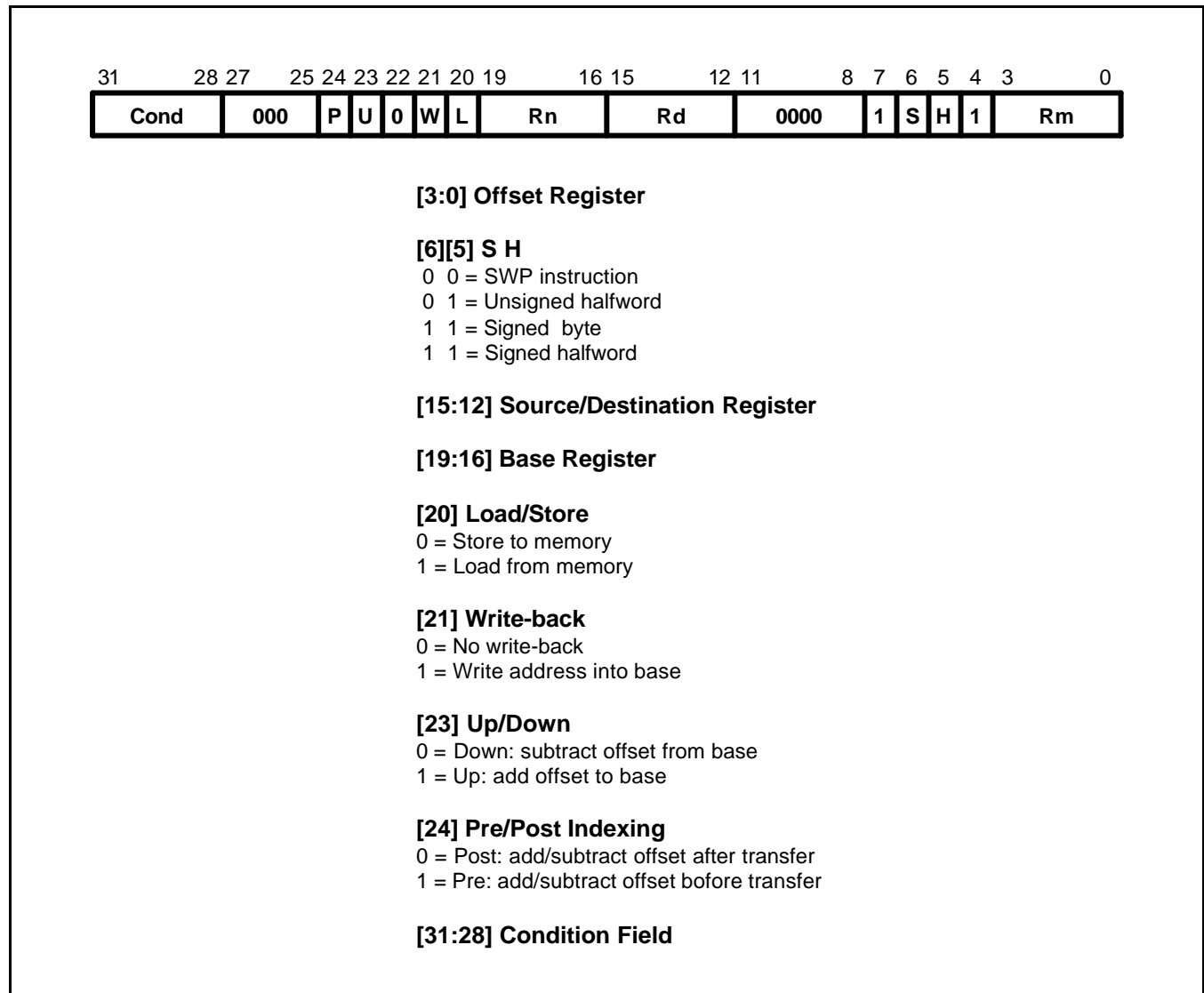

Figure 3-16. Halfword and Signed Data Transfer with Register Offset

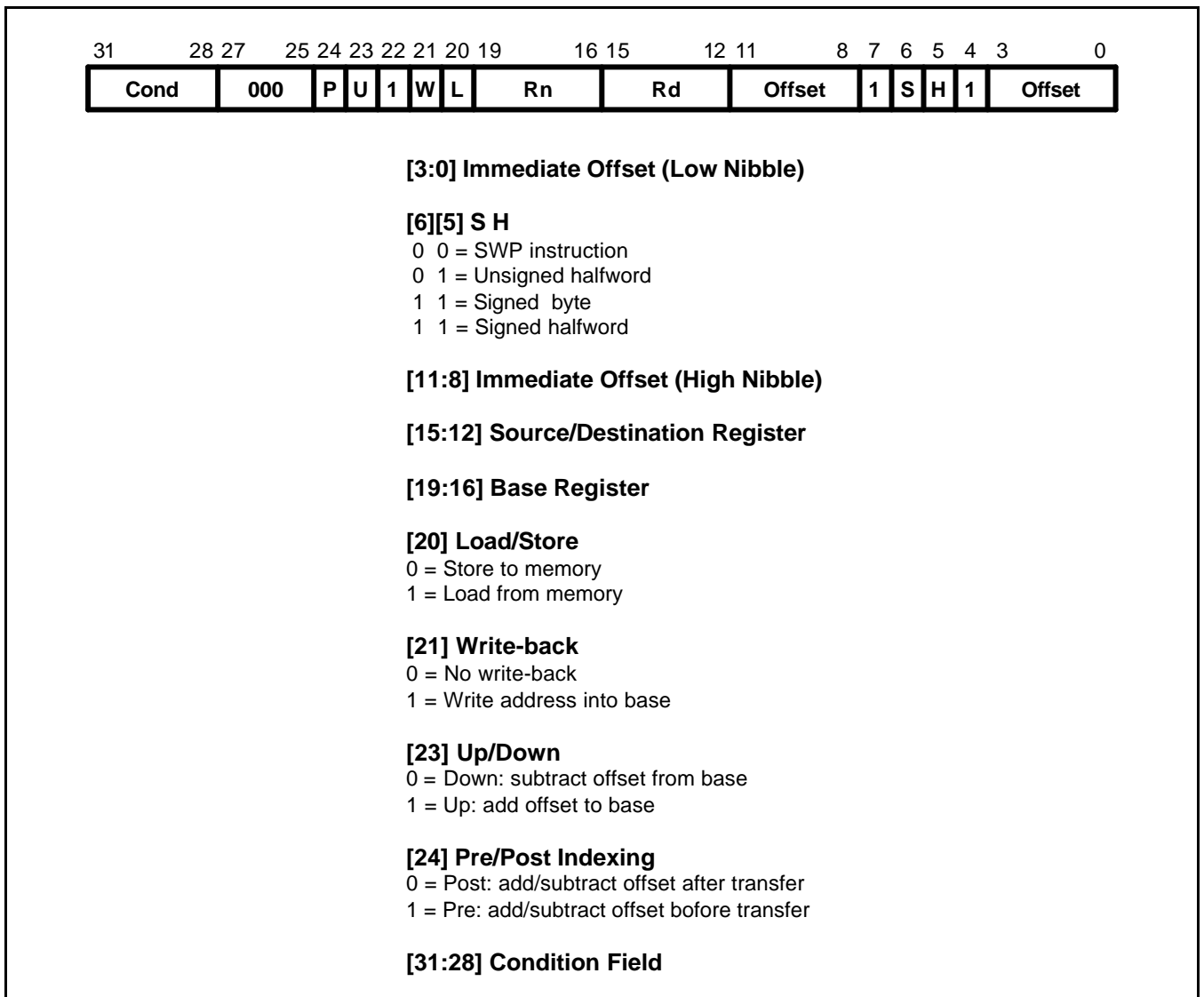

Figure 3-17. Halfword and Signed Data Transfer with Immediate Offset and Auto-Indexing

OFFSETS AND AUTO-INDEXING

The offset from the base may be either a 8-bit unsigned binary immediate value in the instruction, or a second register. The 8-bit offset is formed by concatenating bits 11 to 8 and bits 3 to 0 of the instruction word, such that bit 11 becomes the MSB and bit 0 becomes the LSB. The offset may be added to (U=1) or subtracted from (U=0) the base register Rn. The offset modification may be performed either before (pre-indexed, P=1) or after (post-indexed, P=0) the base register is used as the transfer address.

The W bit gives optional auto-increment and decrement addressing modes. The modified base value may be written back into the base (W=1), or the old base may be kept (W=0). In the case of post-indexed addressing, the write back bit is redundant and is always set to zero, since the old base value can be retained if necessary by setting the offset to zero. Therefore post-indexed data transfers always write back the modified base.

The Write-back bit should not be set high (W=1) when post-indexed addressing is selected.

HALFWORD LOAD AND STORES

Setting S=0 and H=1 may be used to transfer unsigned Half-words between an ARM920T register and memory.

The action of LDRH and STRH instructions is influenced by the BIGEND control signal. The two possible configurations are described in the section below.

Signed byte and halfword loads

The S bit controls the loading of sign-extended data. When S=1 the H bit selects between Bytes (H=0) and Half-words (H=1). The L bit should not be set low (Store) when Signed (S=1) operations have been selected.

The LDRSB instruction loads the selected Byte into bits 7 to 0 of the destination register and bits 31 to 8 of the destination register are set to the value of bit 7, the sign bit.

The LDRSH instruction loads the selected Half-word into bits 15 to 0 of the destination register and bits 31 to 16 of the destination register are set to the value of bit 15, the sign bit.

The action of the LDRSB and LDRSH instructions is influenced by the BIGEND control signal. The two possible configurations are described in the following section.

Endianness and byte/halfword selection

Little-Endian Configuration

A signed byte load (LDRSB) expects data on data bus inputs 7 through to 0 if the supplied address is on a word boundary, on data bus inputs 15 through to 8 if it is a word address plus one byte, and so on. The selected byte is placed in the bottom 8 bit of the destination register, and the remaining bits of the register are filled with the sign bit, bit 7 of the byte. Please see Figure 2-2.

A halfword load (LDRSH or LDRH) expects data on data bus inputs 15 through to 0 if the supplied address is on a word boundary and on data bus inputs 31 through to 16 if it is a halfword boundary, (A[1]=1). The supplied address should always be on a halfword boundary. If bit 0 of the supplied address is HIGH then the ARM920T will load an unpredictable value. The selected halfword is placed in the bottom 16 bits of the destination register. For unsigned half-words (LDRH), the top 16 bits of the register are filled with zeros and for signed half-words (LDRSH) the top 16 bits are filled with the sign bit, bit 15 of the halfword.

A halfword store (STRH) repeats the bottom 16 bits of the source register twice across the data bus outputs 31 through to 0. The external memory system should activate the appropriate halfword subsystem to store the data. Note that the address must be halfword aligned, if bit 0 of the address is HIGH this will cause unpredictable behaviour.

Big-Endian Configuration

A signed byte load (LDRSB) expects data on data bus inputs 31 through to 24 if the supplied address is on a word boundary, on data bus inputs 23 through to 16 if it is a word address plus one byte, and so on. The selected byte is placed in the bottom 8 bit of the destination register, and the remaining bits of the register are filled with the sign bit, bit 7 of the byte. Please see Figure 2-1.

A halfword load (LDRSH or LDRH) expects data on data bus inputs 31 through to 16 if the supplied address is on a word boundary and on data bus inputs 15 through to 0 if it is a halfword boundary, ($A[1]=1$). The supplied address should always be on a halfword boundary. If bit 0 of the supplied address is HIGH then the ARM920T will load an unpredictable value. The selected halfword is placed in the bottom 16 bits of the destination register. For unsigned half-words (LDRH), the top 16 bits of the register are filled with zeros and for signed half-words (LDRSH) the top 16 bits are filled with the sign bit, bit 15 of the halfword.

A halfword store (STRH) repeats the bottom 16 bits of the source register twice across the data bus outputs 31 through to 0. The external memory system should activate the appropriate halfword subsystem to store the data.

NOTE

Please note that the address must be halfword aligned, if bit 0 of the address is HIGH this will cause unpredictable behavior.

USE OF R15

Write-back should not be specified if R15 is specified as the base register (R_n). While using R15 as the base register you must remember it contains address 8 bytes on from the address of the current instruction.

R15 should not be specified as the register offset (R_m).

When R15 is the source register (R_d) of a Half-word store (STRH) instruction, the stored address will be address of the instruction plus 12.

DATA ABORTS

A transfer to or from a legal address may cause problems for a memory management system. For instance, in a system which uses virtual memory the required data may be absent from the main memory. The memory manager can signal a problem by taking the processor ABORT input HIGH whereupon the Data Abort trap will be taken. It is up to the system software to resolve the cause of the problem, then the instruction can be restarted and the original program continued.

INSTRUCTION CYCLE TIMES

Normal LDR(H,SH,SB) instructions take $1S + 1N + 1I$. LDR(H,SH,SB) PC take $2S + 2N + 1I$ incremental cycles. S,N and I are defined as sequential (S-cycle), non-sequential (N-cycle), and internal (I-cycle), respectively. STRH instructions take $2N$ incremental cycles to execute.

ASSEMBLER SYNTAX

<LDR|STR>{cond}<H|SH|SB> Rd,<address>

LDR	Load from memory into a register
STR	Store from a register into memory
{cond}	Two-character condition mnemonic. See Table 3-2.
H	Transfer halfword quantity
SB	Load sign extended byte (Only valid for LDR)
SH	Load sign extended halfword (Only valid for LDR)
Rd	An expression evaluating to a valid register number.

<address> can be:

- 1 An expression which generates an address:
The assembler will attempt to generate an instruction using the PC as a base and a corrected immediate offset to address the location given by evaluating the expression. This will be a PC relative, pre-indexed address. If the address is out of range, an error will be generated.
- 2 A pre-indexed addressing specification:

[Rn]	offset of zero
[Rn,<#expression>]{!}	offset of <expression> bytes
[Rn,{+/-}Rm]{!}	offset of +/- contents of index register
- 3 A post-indexed addressing specification:

[Rn],<#expression>	offset of <expression> bytes
[Rn],{+/-}Rm	offset of +/- contents of index register.
- 4 Rn and Rm are expressions evaluating to a register number. If Rn is R15 then the assembler will subtract 8 from the offset value to allow for ARM920T pipelining. In this case base write-back should not be specified.
- {!} Writes back the base register (set the W bit) if ! is present.

EXAMPLES

LDRH	R1,[R2,-R3]!	; Load R1 from the contents of the halfword address ; contained in R2-R3 (both of which are registers) ; and write back address to R2
STRH	R3,[R4,#14]	; Store the halfword in R3 at R14+14 but don't write back.
LDRSB	R8,[R2],#-223	; Load R8 with the sign extended contents of the byte ; address contained in R2 and write back R2-223 to R2.
LDRNESH	R11,[R0]	; Conditionally load R11 with the sign extended contents ; of the halfword address contained in R0.
HERE		; Generate PC relative offset to address FRED.
STRH	R5, [PC,#(FRED-HERE-8)];	Store the halfword in R5 at address FRED
FRED		

BLOCK DATA TRANSFER (LDM, STM)

The instruction is only executed if the condition is true. The various conditions are defined in Table 3-2. The instruction encoding is shown in Figure 3-18.

Block data transfer instructions are used to load (LDM) or store (STM) any subset of the currently visible registers. They support all possible stacking modes, maintaining full or empty stacks which can grow up or down memory, and are very efficient instructions for saving or restoring context, or for moving large blocks of data around main memory.

THE REGISTER LIST

The instruction can cause the transfer of any registers in the current bank (and non-user mode programs can also transfer to and from the user bank, see below). The register list is a 16 bit field in the instruction, with each bit corresponding to a register. A 1 in bit 0 of the register field will cause R0 to be transferred, a 0 will cause it not to be transferred; similarly bit 1 controls the transfer of R1, and so on.

Any subset of the registers, or all the registers, may be specified. The only restriction is that the register list should not be empty.

Whenever R15 is stored to memory the stored value is the address of the STM instruction plus 12.

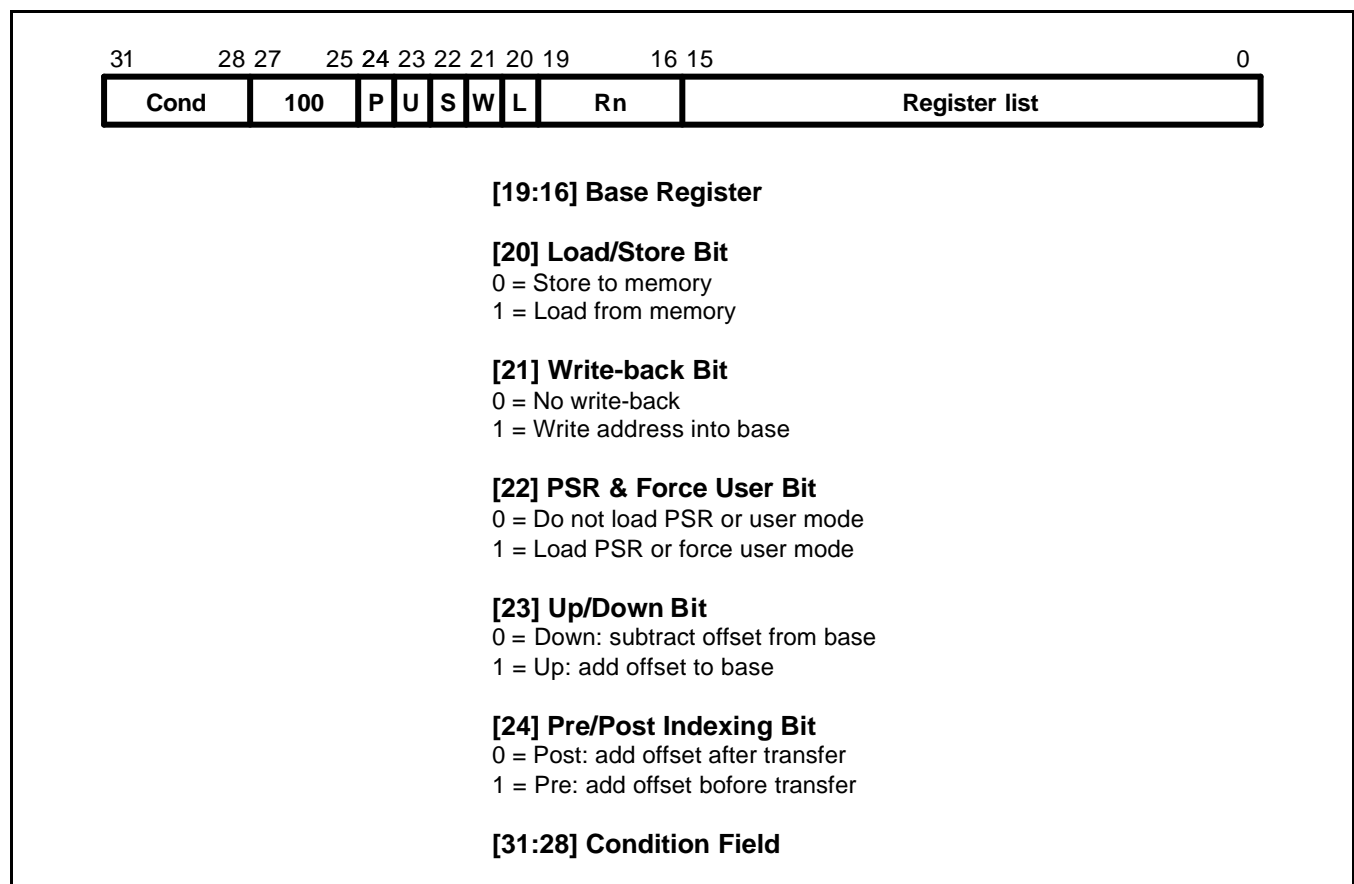

Figure 3-18. Block Data Transfer Instructions

ADDRESSING MODES

The transfer addresses are determined by the contents of the base register (Rn), the pre/post bit (P) and the up/down bit (U). The registers are transferred in the order lowest to highest, so R15 (if in the list) will always be transferred last. The lowest register also gets transferred to/from the lowest memory address. By way of illustration, consider the transfer of R1, R5 and R7 in the case where Rn=0x1000 and write back of the modified base is required (W=1). Figure 3.19-22 show the sequence of register transfers, the addresses used, and the value of Rn after the instruction has completed.

In all cases, had write back of the modified base not been required (W=0), Rn would have retained its initial value of 0x1000 unless it was also in the transfer list of a load multiple register instruction, when it would have been overwritten with the loaded value. **(Please check the meaning again)*******

ADDRESS ALIGNMENT

The address should normally be a word aligned quantity and non-word aligned addresses should not affect the instruction. However, the bottom 2 bits of the address will appear on **A[1:0]** and might be interpreted by the memory system.

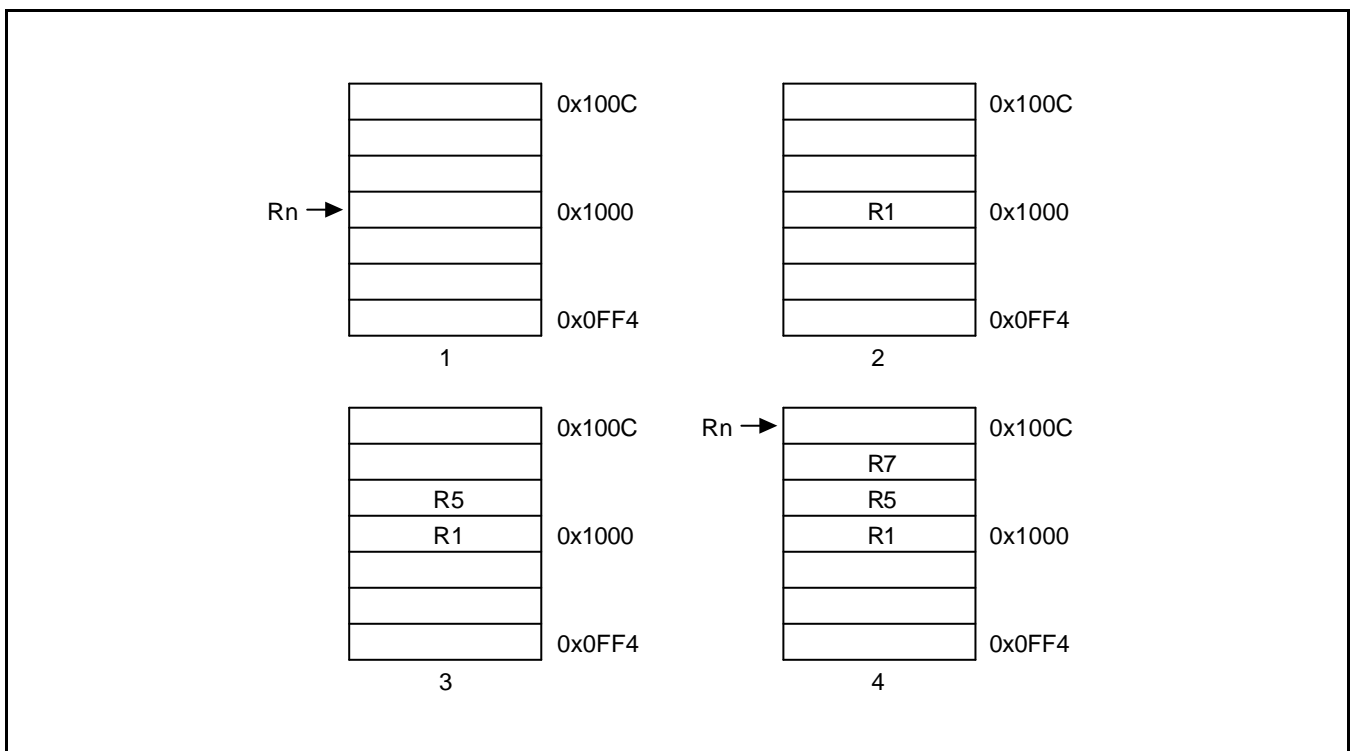

Figure 3-19. Post-Increment Addressing

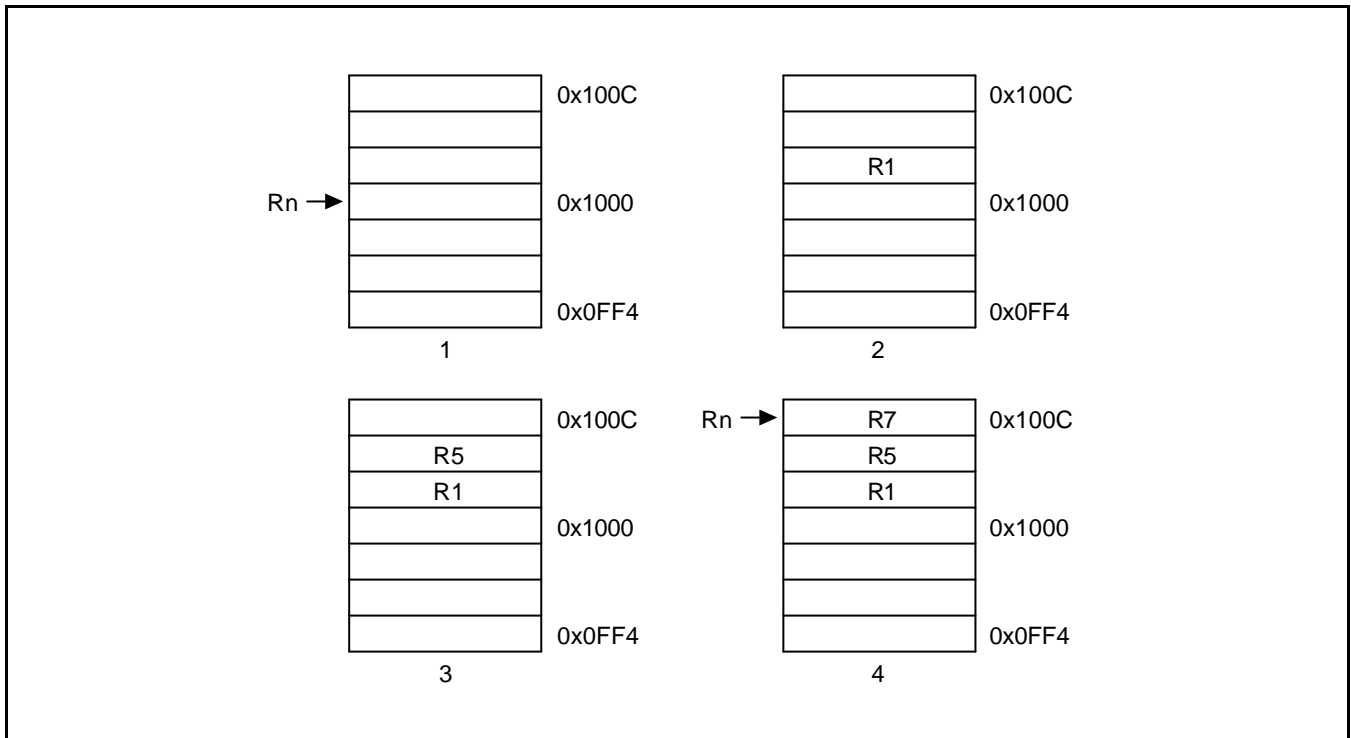

Figure 3-20. Pre-Increment Addressing

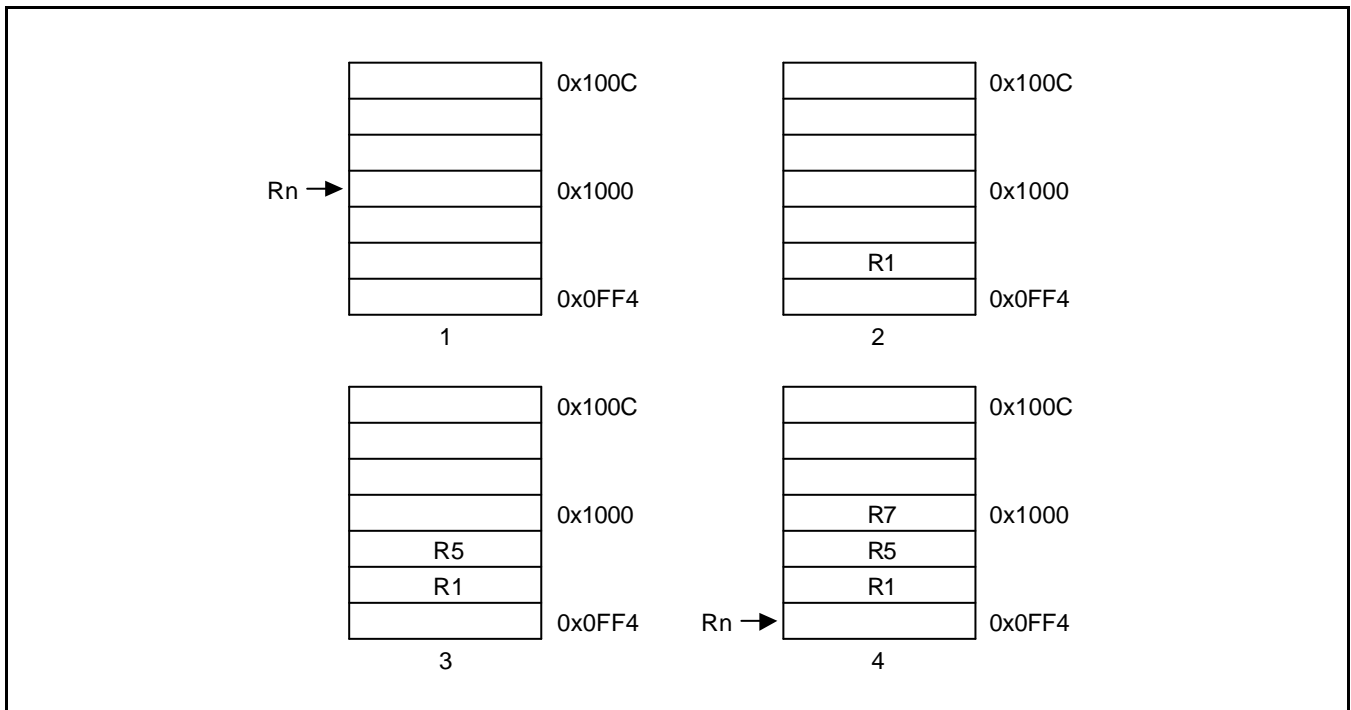

Figure 3-21. Post-Decrement Addressing

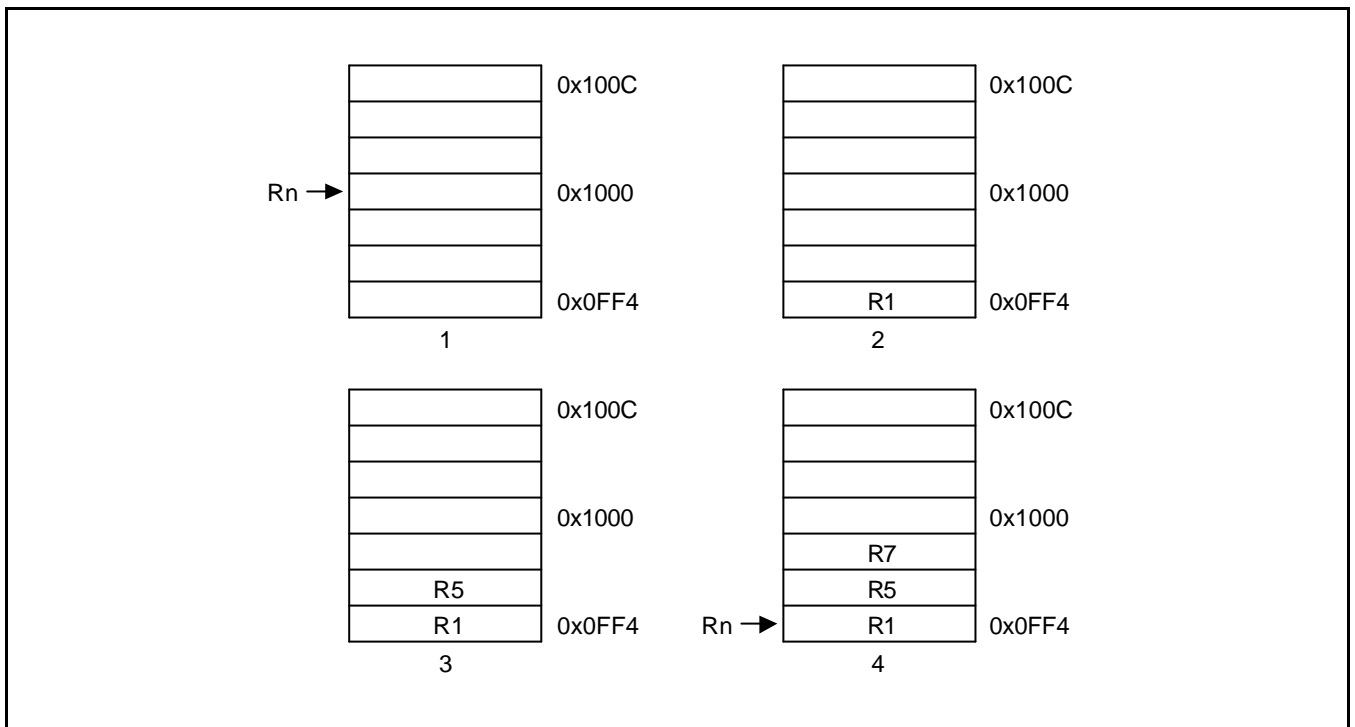

Figure 3-22. Pre-Decrement Addressing

USE OF THE S BIT

When the S bit is set in a LDM/STM instruction it depends on R15 is available in the transfer list and on the type of instruction. The S bit should only be set if the instruction is to execute in a privileged mode.

LDM with R15 in Transfer List and S Bit Set (Mode Changes)

If the instruction is a LDM then `SPSR_<mode>` is transferred to CPSR at the same time as R15 is loaded.

STM with R15 in Transfer List and S Bit Set (User Bank Transfer)

The registers transferred are taken from the User bank rather than the bank corresponding to the current mode. This is useful for saving the user state on process switches. Base write-back should not be used when this mechanism is employed.

R15 not in List and S Bit Set (User Bank Transfer)

For both LDM and STM instructions, the User bank registers are transferred rather than the register bank corresponding to the current mode. This is useful for saving the user state on process switches. Base write-back should not be used when this mechanism is employed.

When the instruction is LDM, care must be taken not to read from a banked register during the following cycle (inserting a dummy instruction such as `MOV R0, R0` after the LDM will ensure safety).

USE OF R15 AS THE BASE

R15 should not be used as the base register in any LDM or STM instruction.

INCLUSION OF THE BASE IN THE REGISTER LIST

When write-back is specified, the base is written back at the end of the second cycle of the instruction. During a STM, the first register is written out at the start of the second cycle. A STM which includes storing the base, with the base as the first register to be stored, will therefore store the unchanged value, whereas with the base second or later in the transfer order, will store the modified value. A LDM will always overwrite the updated base if the base is in the list.

DATA ABORTS

Some legal addresses may be unacceptable to a memory management system, and the memory manager can indicate a problem with an address by taking the **ABORT** signal HIGH. This can happen on any transfer during a multiple register load or store, and must be recoverable if ARM920T is to be used in a virtual memory system.

Abort during STM Instructions

If the abort occurs during a store multiple instruction, ARM920T takes little action until the instruction completes, whereupon it enters the data abort trap. The memory manager is responsible for preventing erroneous writes to the memory. The only change to the internal state of the processor will be the modification of the base register if write-back was specified, and this must be reversed by software (and the cause of the abort resolved) before the instruction may be retried.

Aborts during LDM Instructions

When ARM920T detects a data abort during a load multiple instruction, it modifies the operation of the instruction to ensure that recovery is possible.

- Overwriting of registers stops when the abort happens. The aborting load will not take place but earlier ones may have overwritten registers. The PC is always the last register to be written and so will always be preserved.
- The base register is restored, to its modified value if write-back was requested. This ensures recoverability in the case where the base register is also in the transfer list, and may have been overwritten before the abort occurred.

The data abort trap is taken when the load multiple has completed, and the system software must undo any base modification (and resolve the cause of the abort) before restarting the instruction.

INSTRUCTION CYCLE TIMES

Normal LDM instructions take $nS + 1N + 1I$ and LDM PC takes $(n+1)S + 2N + 1I$ incremental cycles, where S,N and I are defined as sequential (S-cycle), non-sequential (N-cycle), and internal (I-cycle), respectively. STM instructions take $(n-1)S + 2N$ incremental cycles to execute, where n is the number of words transferred.

ASSEMBLER SYNTAX

<LDM|STM>{cond}<FD|ED|FA|EA|IA|IB|DA|DB> Rn{!},<Rlist>{^}

where:

{cond}	Two character condition mnemonic. See Table 3-2.
Rn	An expression evaluating to a valid register number
<Rlist>	A list of registers and register ranges enclosed in {} (e.g. {R0,R2-R7,R10}).
{!}	If present requests write-back (W=1), otherwise W=0.
{^}	If present set S bit to load the CPSR along with the PC, or force transfer of user bank when in privileged mode.

Addressing Mode Names

There are different assembler mnemonics for each of the addressing modes, depending on whether the instruction is being used to support stacks or for other purposes. The equivalence between the names and the values of the bits in the instruction are shown in the following table 3-6.

Table 3-6. Addressing Mode Names

Name	Stack	Other	L Bit	P Bit	U Bit
Pre-Increment Load	LDMED	LDMIB	1	1	1
Post-Increment Load	LDMFD	LDMIA	1	0	1
Pre-Decrement Load	LDMEA	LDMDB	1	1	0
Post-Decrement Load	LDMFA	LDMDA	1	0	0
Pre-Increment Store	STMFA	STMIB	0	1	1
Post-Increment Store	STMEA	STMIA	0	0	1
Pre-Decrement Store	STMFD	STMDB	0	1	0
Post-Decrement Store	STMED	STMDA	0	0	0

FD, ED, FA, EA define pre/post indexing and the up/down bit by reference to the form of stack required. The F and E refer to a "full" or "empty" stack, i.e. whether a pre-index has to be done (full) before storing to the stack. The A and D refer to whether the stack is ascending or descending. If ascending, a STM will go up and LDM down, if descending, vice-versa.

IA, IB, DA, DB allow control when LDM/STM are not being used for stacks and simply mean Increment After, Increment Before, Decrement After, Decrement Before.

EXAMPLES

```
LDMFD    SP!,{R0,R1,R2}    ; Unstack 3 registers.
STMIA    R0,{R0-R15}      ; Save all registers.
LDMFD    SP!,{R15}        ; R15 ← (SP), CPSR unchanged.
LDMFD    SP!,{R15}^      ; R15 ← (SP), CPSR ← SPSR_mode
                                     ; (allowed only in privileged modes).
STMFD    R13,{R0-R14}^    ; Save user mode regs on stack
                                     ; (allowed only in privileged modes).
```

These instructions may be used to save state on subroutine entry, and restore it efficiently on return to the calling routine:

```
STMED    SP!,{R0-R3,R14}  ; Save R0 to R3 to use as workspace
                                     ; and R14 for returning.
BL       somewhere        ; This nested call will overwrite R14
LDMED    SP!,{R0-R3,R15}  ; Restore workspace and return.
```

SINGLE DATA SWAP (SWP)

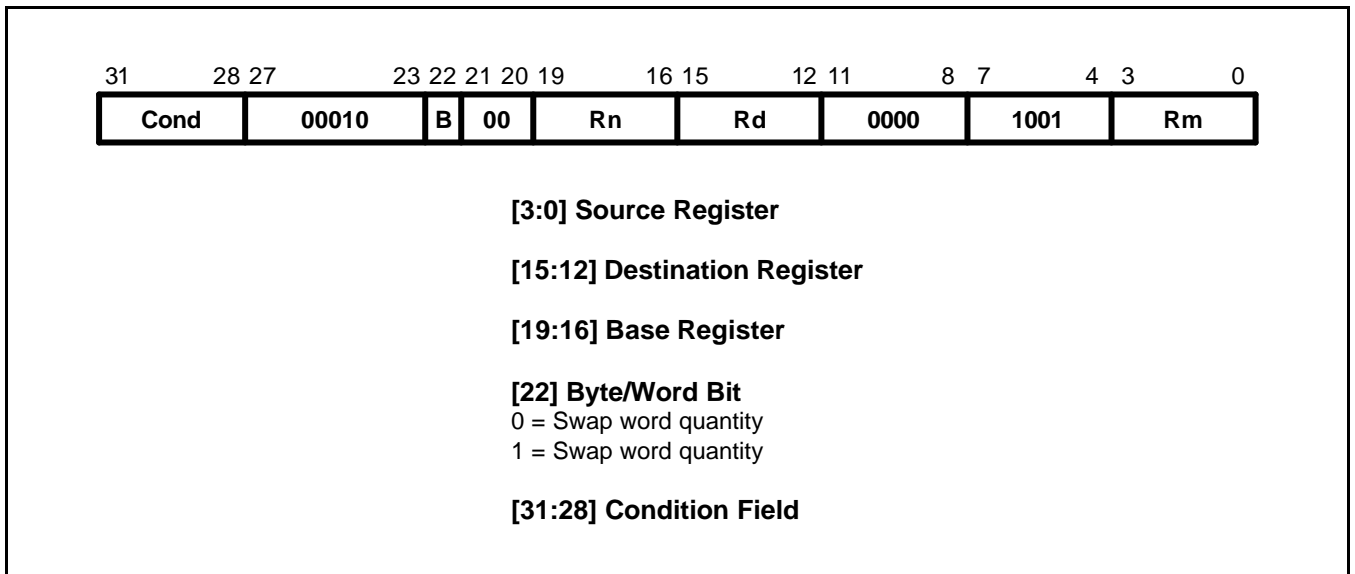

Figure 3-23. Swap Instruction

The instruction is only executed if the condition is true. The various conditions are defined in Table 3-2. The instruction encoding is shown in Figure 3-23.

The data swap instruction is used to swap a byte or word quantity between a register and external memory. This instruction is implemented as a memory read followed by a memory write which are “locked” together (the processor cannot be interrupted until both operations have completed, and the memory manager is warned to treat them as inseparable). This class of instruction is particularly useful for implementing software semaphores.

The swap address is determined by the contents of the base register (Rn). The processor first reads the contents of the swap address. Then it writes the contents of the source register (Rm) to the swap address, and stores the old memory contents in the destination register (Rd). The same register may be specified as both the source and destination.

The **LOCK** output goes HIGH for the duration of the read and write operations to signal to the external memory manager that they are locked together, and should be allowed to complete without interruption. This is important in multi-processor systems where the swap instruction is the only indivisible instruction which may be used to implement semaphores; control of the memory must not be removed from a processor while it is performing a locked operation.

BYTES AND WORDS

This instruction class may be used to swap a byte (B=1) or a word (B=0) between an ARM920T register and memory. The SWP instruction is implemented as a LDR followed by a STR and the action of these is as described in the section on single data transfers. In particular, the description of Big and Little Endian configuration applies to the SWP instruction.

USE OF R15

Do not use R15 as an operand (Rd, Rn or Rs) in a SWP instruction.

DATA ABORTS

If the address used for the swap is unacceptable to a memory management system, the memory manager can flag the problem by driving ABORT HIGH. This can happen on either the read or the write cycle (or both), and in either case, the Data Abort trap will be taken. It is up to the system software to resolve the cause of the problem, then the instruction can be restarted and the original program continued.

INSTRUCTION CYCLE TIMES

Swap instructions take $1S + 2N + 1I$ incremental cycles to execute, where S,N and I are defined as sequential (S-cycle), non-sequential, and internal (I-cycle), respectively.

ASSEMBLER SYNTAX

<SWP>{cond}{B} Rd,Rm,[Rn]

{cond} Two-character condition mnemonic. See Table 3-2.

{B} If B is present then byte transfer, otherwise word transfer

Rd,Rm,Rn Expressions evaluating to valid register numbers

Examples

SWP	R0,R1,[R2]	; Load R0 with the word addressed by R2, and ; store R1 at R2.
SWPB	R2,R3,[R4]	; Load R2 with the byte addressed by R4, and ; store bits 0 to 7 of R3 at R4.
SWPEQ	R0,R0,[R1]	; Conditionally swap the contents of the ; word addressed by R1 with R0.

SOFTWARE INTERRUPT (SWI)

The instruction is only executed if the condition is true. The various conditions are defined in Table 3-2. The instruction encoding is shown in Figure 3-24, below.

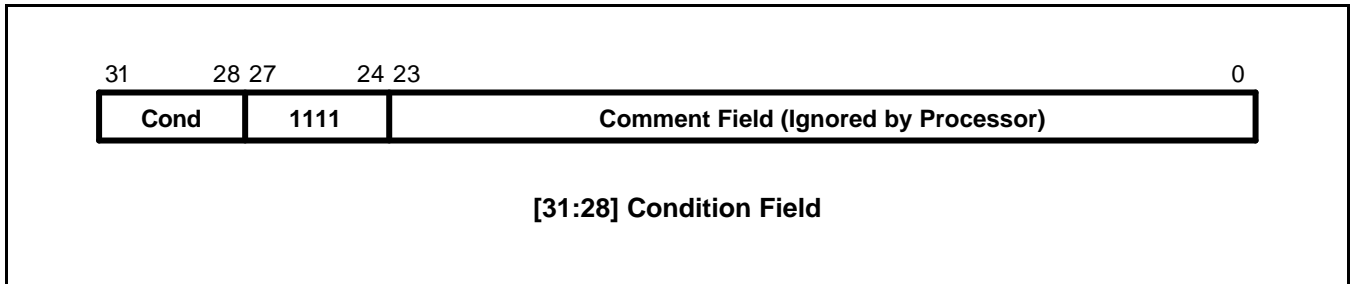

Figure 3-24. Software Interrupt Instruction

The software interrupt instruction is used to enter Supervisor mode in a controlled manner. The instruction causes the software interrupt trap to be taken, which effects the mode change. The PC is then forced to a fixed value (0x08) and the CPSR is saved in SPSR_svc. If the SWI vector address is suitably protected (by external memory management hardware) from modification by the user, a fully protected operating system may be constructed.

RETURN FROM THE SUPERVISOR

The PC is saved in R14_svc upon entering the software interrupt trap, with the PC adjusted to point to the word after the SWI instruction. MOVS PC,R14_svc will return to the calling program and restore the CPSR.

Note that the link mechanism is not re-entrant, so if the supervisor code wishes to use software interrupts within itself it must first save a copy of the return address and SPSR.

COMMENT FIELD

The bottom 24 bits of the instruction are ignored by the processor, and may be used to communicate information to the supervisor code. For instance, the supervisor may look at this field and use it to index into an array of entry points for routines which perform the various supervisor functions.

INSTRUCTION CYCLE TIMES

Software interrupt instructions take $2S + 1N$ incremental cycles to execute, where S and N are defined as sequential (S-cycle) and non-sequential (N-cycle).

ASSEMBLER SYNTAX

SWI{cond} <expression>

{cond} Two character condition mnemonic, Table 3-2.

<expression> Evaluated and placed in the comment field (which is ignored by ARM920T).

Examples

```

SWI      ReadC           ; Get next character from read stream.
SWI      Writel+"k"     ; Output a "k" to the write stream.
SWINE    0               ; Conditionally call supervisor with 0 in comment field.

```

Supervisor code

The previous examples assume that suitable supervisor code exists, for instance:

```

0x08 B Supervisor       ; SWI entry point
EntryTable              ; Addresses of supervisor routines
DCD ZeroRtn
DCD ReadCRtn
DCD WritelRtn
...
Zero EQU 0
ReadC EQU 256
Writel EQU 512

Supervisor              ; SWI has routine required in bits 8-23 and data (if any) in
                        ; bits 0-7. Assumes R13_svc points to a suitable stack
STMFD R13,{R0-R2,R14}  ; Save work registers and return address.
LDR R0,[R14,#-4]        ; Get SWI instruction.
BIC R0,R0,#0xFF000000   ; Clear top 8 bits.
MOV R1,R0,LSR#8         ; Get routine offset.
ADR R2,EntryTable      ; Get start address of entry table.
LDR R15,[R2,R1,LSL#2]  ; Branch to appropriate routine.
WritelRtn              ; Enter with character in R0 bits 0-7.
...
LDMFD R13,{R0-R2,R15}^ ; Restore workspace and return,
                        ; restoring processor mode and flags.

```

COPROCESSOR DATA OPERATIONS (CDP)

The instruction is only executed if the condition is true. The various conditions are defined in Table 3-2. The instruction encoding is shown in Figure 3-25.

This class of instruction is used to tell a coprocessor to perform some internal operation. No result is communicated back to ARM920T, and it will not wait for the operation to complete. The coprocessor could contain a queue of such instructions awaiting execution, and their execution can overlap other activity, allowing the coprocessor and ARM920T to perform independent tasks in parallel.

COPROCESSOR INSTRUCTIONS

The S3C2440A, unlike some other ARM-based processors, does not have an external coprocessor interface. It does not have a on-chip coprocessor also.

So then all coprocessor instructions will cause the undefined instruction trap to be taken on the S3C2440A. These coprocessor instructions can be emulated by the undefined trap handler. Even though external coprocessor can not be connected to the S3C2440A, the coprocessor instructions are still described here in full for completeness. (Remember that any external coprocessor described in this section is a software emulation.)

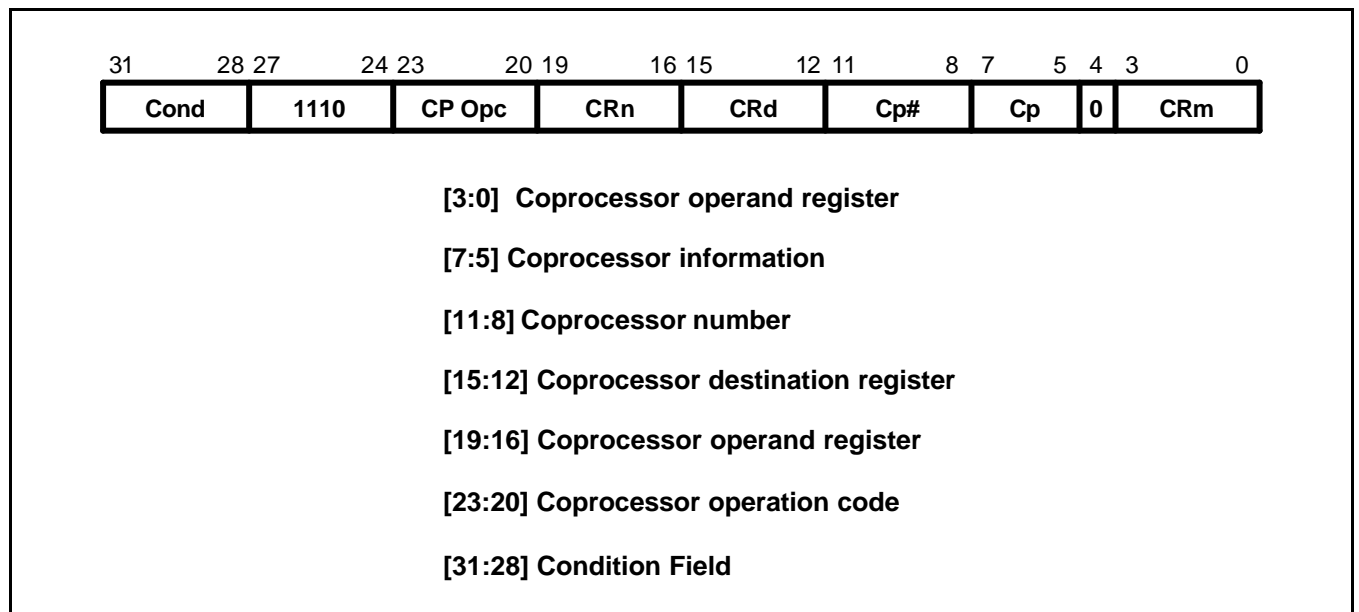

Figure 3-25. Coprocessor Data Operation Instruction

Only bit 4 and bits 24 to 31 The coprocessor fields are significant to ARM920T. The remaining bits are used by coprocessors. The above field names are used by convention, and particular coprocessors may redefine the use of all fields except CP# as appropriate. The CP# field is used to contain an identifying number (in the range 0 to 15) for each coprocessor, and a coprocessor will ignore any instruction which does not contain its number in the CP# field.

The conventional interpretation of the instruction is that the coprocessor should perform an operation specified in the CP Opc field (and possibly in the CP field) on the contents of CRn and CRm, and place the result in CRd.

INSTRUCTION CYCLE TIMES

Coprocessor data operations take $1S + bI$ incremental cycles to execute, where b is the number of cycles spent in the coprocessor busy-wait loop.

S and I are defined as sequential (S-cycle) and internal (I-cycle).

Assembler syntax

CDP{cond} p#,<expression1>,cd,cn,cm{,<expression2>}

{cond}	Two character condition mnemonic. See Table 3-2.
p#	The unique number of the required coprocessor
<expression1>	Evaluated to a constant and placed in the CP Opc field
cd, cn and cm	Evaluate to the valid coprocessor register numbers CRd, CRn and CRm respectively
<expression2>	Where present is evaluated to a constant and placed in the CP field

EXAMPLES

CDP	p1,10,c1,c2,c3	; Request coproc 1 to do operation 10
		; on CR2 and CR3, and put the result in CR1.
CDPEQ	p2,5,c1,c2,c3,2	; If Z flag is set request coproc 2 to do operation 5 (type 2)
		; on CR2 and CR3, and put the result in CR1.

COPROCESSOR DATA TRANSFERS (LDC, STC)

The instruction is only executed if the condition is true. The various conditions are defined in Table 3-2. The instruction encoding is shown in Figure 3-26.

This class of instruction is used to load (LDC) or store (STC) a subset of a coprocessor's registers directly to memory. ARM920T is responsible for supplying the memory address and the coprocessor supplies or accepts the data and controls the number of words transferred.

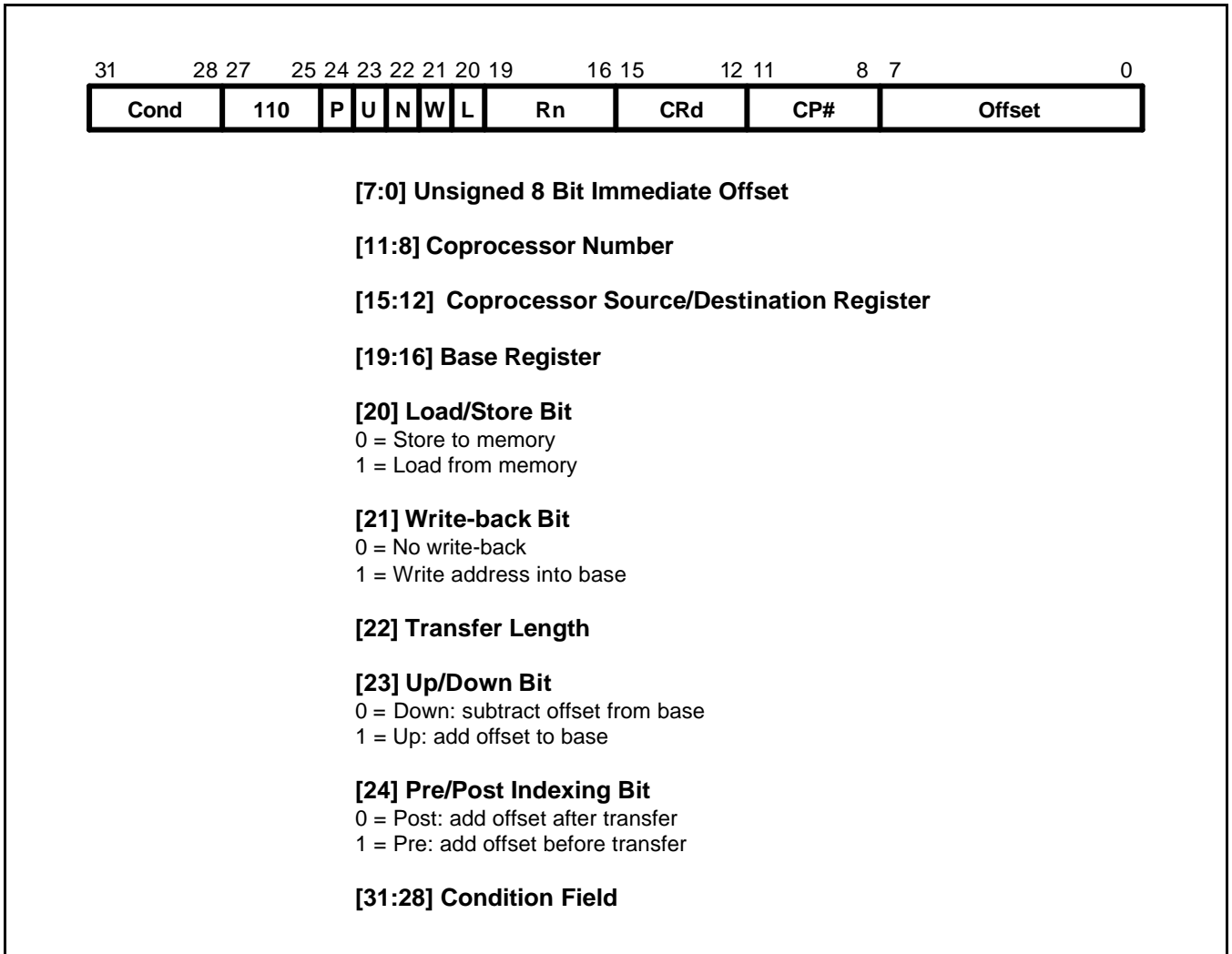

Figure 3-26. Coprocessor Data Transfer Instructions

THE COPROCESSOR FIELDS

The CP# field is used to identify the coprocessor which is required to supply or accept the data, and a coprocessor will only respond if its number matches the contents of this field.

The CRd field and the N bit contain information for the coprocessor which may be interpreted in different ways by different coprocessors, but by convention CRd is the register to be transferred (or the first register where more than one is to be transferred), and the N bit is used to choose one of two transfer length options. For instance N=0 could select the transfer of a single register, and N=1 could select the transfer of all the registers for context switching.

ADDRESSING MODES

ARM920T is responsible for providing the address used by the memory system for the transfer, and the addressing modes available are a subset of those used in single data transfer instructions. Note, however, that the immediate offsets are 8 bits wide and specify word offsets for coprocessor data transfers, whereas they are 12 bits wide and specify byte offsets for single data transfers.

The 8 bit unsigned immediate offset is shifted left 2 bits and either added to (U=1) or subtracted from (U=0) the base register (Rn); this calculation may be performed either before (P=1) or after (P=0) the base is used as the transfer address. The modified base value may be overwritten back into the base register (if W=1), or the old value of the base may be preserved (W=0). Note that post-indexed addressing modes require explicit setting of the W bit, unlike LDR and STR which always write-back when post-indexed.

The value of the base register, modified by the offset in a pre-indexed instruction, is used as the address for the transfer of the first word. The second word (if more than one is transferred) will go to or come from an address one word (4 bytes) higher than the first transfer, and the address will be incremented by one word for each subsequent transfer.

ADDRESS ALIGNMENT

The base address should normally be a word aligned quantity. The bottom 2 bits of the address will appear on **A[1:0]** and might be interpreted by the memory system.

Use of R15

If Rn is R15, the value used will be the address of the instruction plus 8 bytes. Base write-back to R15 must not be specified.

DATA ABORTS

If the address is legal but the memory manager generates an abort, the data trap will be taken. The write-back of the modified base will take place, but all other processor state will be preserved. The coprocessor is partly responsible for ensuring that the data transfer can be restarted after the cause of the abort has been resolved, and must ensure that any subsequent actions it undertakes can be repeated when the instruction is retried.

Instruction cycle times

Coprocessor data transfer instructions take $(n-1)S + 2N + bI$ incremental cycles to execute, where:

n The number of words transferred.

b The number of cycles spent in the coprocessor busy-wait loop.

S, N and I are defined as sequential (S-cycle), non-sequential (N-cycle), and internal (I-cycle), respectively.

ASSEMBLER SYNTAX

<LDC|STC>{cond}{L} p#,cd,<Address>

LDC	Load from memory to coprocessor
STC	Store from coprocessor to memory
{L}	When present perform long transfer (N=1), otherwise perform short transfer (N=0)
{cond}	Two character condition mnemonic. See Table 3-2..
p#	The unique number of the required coprocessor
cd	An expression evaluating to a valid coprocessor register number that is placed in the CRd field
<Address>	can be:
1	An expression which generates an address: The assembler will attempt to generate an instruction using the PC as a base and a corrected immediate offset to address the location given by evaluating the expression. This will be a PC relative, pre-indexed address. If the address is out of range, an error will be generated
2	A pre-indexed addressing specification: [Rn] offset of zero [Rn,<#expression>](!) offset of <expression> bytes
3	A post-indexed addressing specification: [Rn],<#expression> offset of <expression> bytes {!} write back the base register (set the W bit) if ! is present Rn is an expression evaluating to a valid ARM920T register number.

NOTE

If Rn is R15, the assembler will subtract 8 from the offset value to allow for ARM920T pipelining.

EXAMPLES

LDC	p1,c2,table	; Load c2 of coproc 1 from address
		; table, using a PC relative address.
STCEQL	p2,c3,[R5,#24]!	; Conditionally store c3 of coproc 2
		; into an address 24 bytes up from R5,
		; write this address back to R5, and use
		; long transfer option (probably to store multiple words).

NOTE

Although the address offset is expressed in bytes, the instruction offset field is in words. The assembler will adjust the offset appropriately.

COPROCESSOR REGISTER TRANSFERS (MRC, MCR)

The instruction is only executed if the condition is true. The various conditions are defined in Table 3-2. The instruction encoding is shown in Figure 3-27.

This class of instruction is used to communicate information directly between ARM920T and a coprocessor. An example of a coprocessor to ARM920T register transfer (MRC) instruction would be a FIX of a floating point value held in a coprocessor, where the floating point number is converted into a 32 bit integer within the coprocessor, and the result is then transferred to ARM920T register. A FLOAT of a 32 bit value in ARM920T register into a floating point value within the coprocessor illustrates the use of ARM920T register to coprocessor transfer (MCR).

An important use of this instruction is to communicate control information directly from the coprocessor into the ARM920T CPSR flags. As an example, the result of a comparison of two floating point values within a coprocessor can be moved to the CPSR to control the subsequent flow of execution.

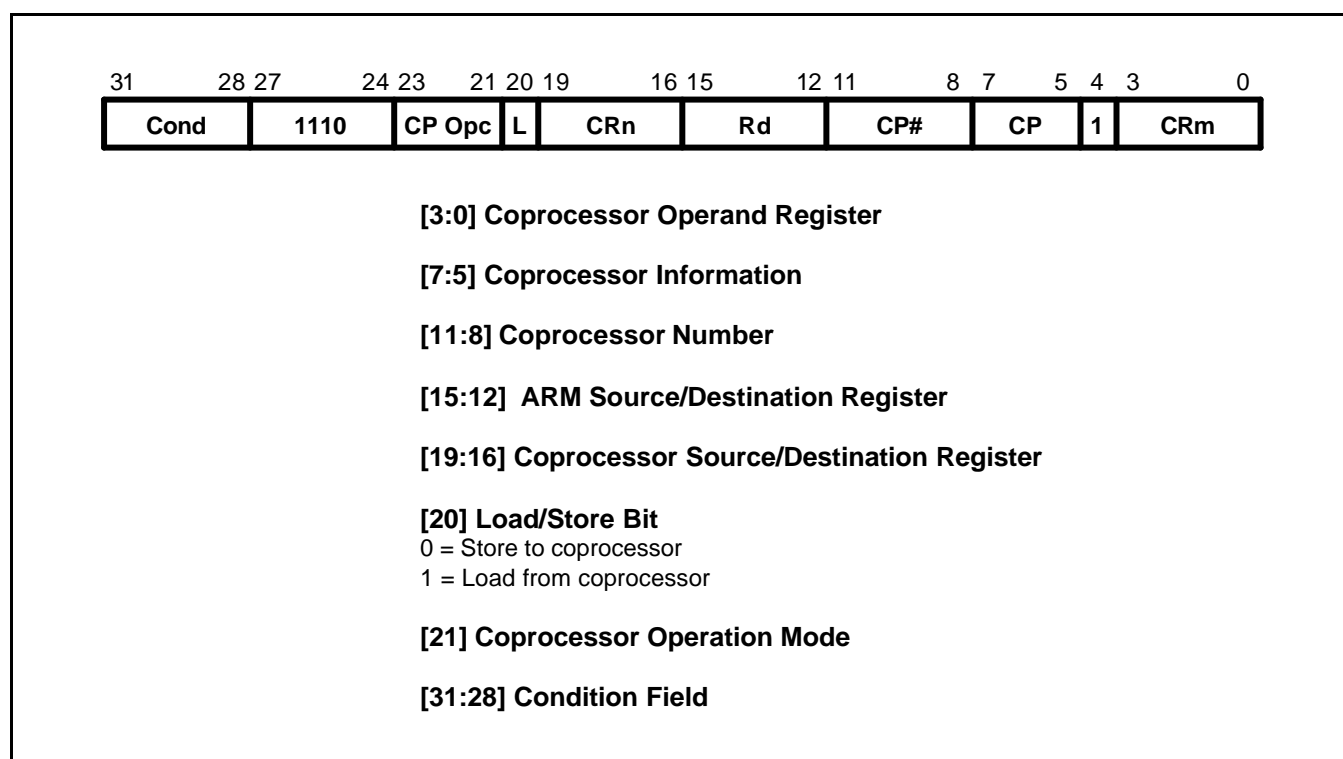

Figure 3-27. Coprocessor Register Transfer Instructions

THE COPROCESSOR FIELDS

The CP# field is used, as for all coprocessor instructions, to specify which coprocessor is being called upon.

The CP Opc, CRn, CP and CRm fields are used only by the coprocessor, and the interpretation presented here is derived from convention only. Other interpretations are allowed where the coprocessor functionality is incompatible with this one. The conventional interpretation is that the CP Opc and CP fields specify the operation the coprocessor is required to perform, CRn is the coprocessor register which is the source or destination of the transferred information, and CRm is a second coprocessor register which may be involved in some way which depends on the particular operation specified.

TRANSFERS TO R15

When a coprocessor register transfer to ARM920T has R15 as the destination, bits 31, 30, 29 and 28 of the transferred word are copied into the N, Z, C and V flags respectively. The other bits of the transferred word are ignored, and the PC and other CPSR bits are unaffected by the transfer.

TRANSFERS FROM R15

A coprocessor register transfer from ARM920T with R15 as the source register will store the PC+12.

INSTRUCTION CYCLE TIMES

MRC instructions take $1S + (b+1)I + 1C$ incremental cycles to execute, where S, I and C are defined as sequential (S-cycle), internal (I-cycle), and coprocessor register transfer (C-cycle), respectively. MCR instructions take $1S + bI + 1C$ incremental cycles to execute, where *b* is the number of cycles spent in the coprocessor busy-wait loop.

ASSEMBLER SYNTAX

<MCR|MRC>{cond} p#,<expression1>,Rd,cn,cm{,<expression2>}

MRC	Move from coprocessor to ARM920T register (L=1)
MCR	Move from ARM920T register to coprocessor (L=0)
{cond}	Two character condition mnemonic. See Table 3-2
p#	The unique number of the required coprocessor
<expression1>	Evaluated to a constant and placed in the CP Opc field
Rd	An expression evaluating to a valid ARM920T register number
cn and cm	Expressions evaluating to the valid coprocessor register numbers CRn and CRm respectively
<expression2>	Where present is evaluated to a constant and placed in the CP field

EXAMPLES

MRC	p2,5,R3,c5,c6	; Request coproc 2 to perform operation 5 ; on c5 and c6, and transfer the (single ; 32-bit word) result back to R3.
MCR	p6,0,R4,c5,c6	; Request coproc 6 to perform operation 0 ; on R4 and place the result in c6.
MRCEQ	p3,9,R3,c5,c6,2	; Conditionally request coproc 3 to ; perform operation 9 (type 2) on c5 and ; c6, and transfer the result back to R3.

UNDEFINED INSTRUCTION

The instruction is only executed if the condition is true. The various conditions are defined in Table 3-2. The instruction format is shown in Figure 3-28.

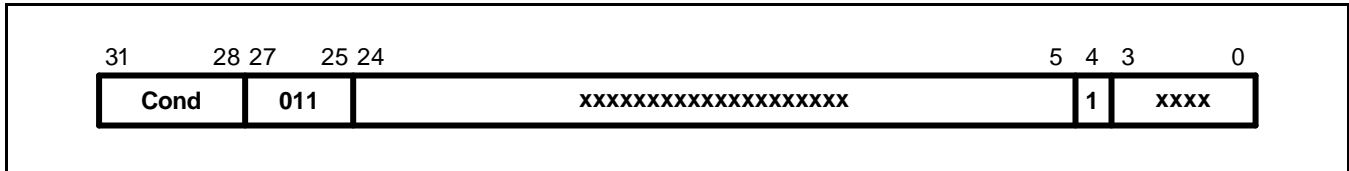

Figure 3-28. Undefined Instruction

If the condition is true, the undefined instruction trap will be taken.

Note that the undefined instruction mechanism involves offering this instruction to any coprocessors which may be present, and all coprocessors must refuse to accept it by driving **CPA** and **CPB** HIGH.

INSTRUCTION CYCLE TIMES

This instruction takes $2S + 1I + 1N$ cycles, where S, N and I are defined as sequential (S-cycle), non-sequential (N-cycle), and internal (I-cycle).

ASSEMBLER SYNTAX

The assembler has no mnemonics for generating this instruction. If it is adopted in the future for some specified use, suitable mnemonics will be added to the assembler. Until such time, this instruction must not be used.

INSTRUCTION SET EXAMPLES

The following examples show ways in which the basic ARM920T instructions can combine to give efficient code. None of these methods saves a great deal of execution time (although they may save some), mostly they just save code.

USING THE CONDITIONAL INSTRUCTIONS

Using Conditionals for Logical OR

```

CMP      Rn,#p          ; If Rn=p OR Rm=q THEN GOTO Label.
BEQ     Label
CMP     Rm,#q
BEQ     Label

```

This can be replaced by

```

CMP      Rn,#p
CMPNE   Rm,#q          ; If condition not satisfied try other test.
BEQ     Label

```

Absolute Value

```

TEQ     Rn,#0          ; Test sign
RSBMI   Rn,Rn,#0      ; and 2's complement if necessary.

```

Multiplication by 4, 5 or 6 (Run Time)

```

MOV     Rc,Ra,LSL#2    ; Multiply by 4,
CMP     Rb,#5          ; Test value,
ADDCS  Rc,Rc,Ra        ; Complete multiply by 5,
ADDHI  Rc,Rc,Ra        ; Complete multiply by 6.

```

Combining Discrete and Range Tests

```

TEQ     Rc,#127        ; Discrete test,
CMPNE   Rc,#"-1       ; Range test
MOVLS   Rc,#"         ; IF Rc<=" OR Rc=ASCII(127)
                          ; THEN Rc:="."

```

Division and Remainder

A number of divide routines for specific applications are provided in source form as part of the ANSI C library provided with the ARM Cross Development Toolkit, available from your supplier. A short general purpose divide routine follows.

			; Enter with numbers in Ra and Rb.
	MOV	Rcnt,#1	; Bit to control the division.
Div1	CMP	Rb,#0x80000000	; Move Rb until greater than Ra.
	CMPCC	Rb,Ra	
	MOVCC	Rb,Rb,ASL#1	
	MOVCC	Rcnt,Rcnt,ASL#1	
	BCC	Div1	
	MOV	Rc,#0	
Div2	CMP	Ra,Rb	; Test for possible subtraction.
	SUBCS	Ra,Ra,Rb	; Subtract if ok,
	ADDCS	Rc,Rc,Rcnt	; Put relevant bit into result
	MOVS	Rcnt,Rcnt,LSR#1	; Shift control bit
	MOVNE	Rb,Rb,LSR#1	; Halve unless finished.
	BNE	Div2	; Divide result in Rc, remainder in Ra.

Overflow Detection in the ARM920T

1. Overflow in unsigned multiply with a 32-bit result

UMULL	Rd,Rt,Rm,Rn	; 3 to 6 cycles
TEQ	Rt,#0	; +1 cycle and a register
BNE	overflow	

2. Overflow in signed multiply with a 32-bit result

SMULL	Rd,Rt,Rm,Rn	; 3 to 6 cycles
TEQ	Rt,Rd ASR#31	; +1 cycle and a register
BNE	overflow	

3. Overflow in unsigned multiply accumulate with a 32 bit result

UMLAL	Rd,Rt,Rm,Rn	; 4 to 7 cycles
TEQ	Rt,#0	; +1 cycle and a register
BNE	overflow	

4. Overflow in signed multiply accumulate with a 32 bit result

SMLAL	Rd,Rt,Rm,Rn	; 4 to 7 cycles
TEQ	Rt,Rd, ASR#31	; +1 cycle and a register
BNE	overflow	

5. Overflow in unsigned multiply accumulate with a 64 bit result

UMULL	RI,Rh,Rm,Rn	; 3 to 6 cycles
ADDS	RI,RI,Ra1	; Lower accumulate
ADC	Rh,Rh,Ra2	; Upper accumulate
BCS	overflow	; 1 cycle and 2 registers

6. Overflow in signed multiply accumulate with a 64 bit result

SMULL	RI,Rh,Rm,Rn	; 3 to 6 cycles
ADDS	RI,RI,Ra1	; Lower accumulate
ADC	Rh,Rh,Ra2	; Upper accumulate
BVS	overflow	; 1 cycle and 2 registers

NOTE

Overflow checking is not applicable to unsigned and signed multiplies with a 64-bit result, since overflow does not occur in such calculations.

PSEUDO-RANDOM BINARY SEQUENCE GENERATOR

It is often necessary to generate (pseudo-) random numbers and the most efficient algorithms are based on shift generators with exclusive-OR feedback rather like a cyclic redundancy check generator. Unfortunately the sequence of a 32 bit generator needs more than one feedback tap to be maximal length (i.e. $2^{32}-1$ cycles before repetition), so this example uses a 33 bit register with taps at bits 33 and 20. The basic algorithm is newbit:=bit 33 eor bit 20, shift left the 33 bit number and put in newbit at the bottom; this operation is performed for all the newbits needed (i.e. 32 bits). The entire operation can be done in 5 S cycles:

		; Enter with seed in Ra (32 bits),
		; Rb (1 bit in Rb lsb), uses Rc.
TST	Rb,Rb,LSR#1	; Top bit into carry
MOVS	Rc,Ra,RRX	; 33 bit rotate right
ADC	Rb,Rb,Rb	; Carry into lsb of Rb
EOR	Rc,Rc,Ra,LSL#12	; (involved!)
EOR	Ra,Rc,Rc,LSR#20	; (similarly involved!) new seed in Ra, Rb as before

MULTIPLICATION BY CONSTANT USING THE BARREL SHIFTER

Multiplication by 2^n (1,2,4,8,16,32..)

MOV Ra, Rb, LSL #n

Multiplication by 2^{n+1} (3,5,9,17..)

ADD Ra,Ra,Ra,LSL #n

Multiplication by 2^{n-1} (3,7,15..)

RSB Ra,Ra,Ra,LSL #n

Multiplication by 6

```

ADD    Ra,Ra,Ra,LSL #1    ; Multiply by 3
MOV    Ra,Ra,LSL#1       ; and then by 2

```

Multiply by 10 and add in extra number

```

ADD    Ra,Ra,Ra,LSL#2    ; Multiply by 5
ADD    Ra,Rc,Ra,LSL#1    ; Multiply by 2 and add in next digit

```

General recursive method for $R_b := R_a * C$, C a constant:

1. If C even, say $C = 2^n * D$, D odd:

```

D=1:    MOV    Rb,Ra,LSL #n
D<>1:   {Rb := Ra*D}
MOV     Rb,Rb,LSL #n

```

2. If $C \text{ MOD } 4 = 1$, say $C = 2^n * D + 1$, D odd, $n > 1$:

```

D=1:    ADD    Rb,Ra,Ra,LSL #n
D<>1:   {Rb := Ra*D}
ADD     Rb,Ra,Rb,LSL #n

```

3. If $C \text{ MOD } 4 = 3$, say $C = 2^n * D - 1$, D odd, $n > 1$:

```

D=1:    RSB   Rb,Ra,Ra,LSL #n
D<>1:   {Rb := Ra*D}
RSB     Rb,Ra,Rb,LSL #n

```

This is not quite optimal, but close. An example of its non-optimality is multiply by 45 which is done by:

```

RSB    Rb,Ra,Ra,LSL#2    ; Multiply by 3
RSB    Rb,Ra,Rb,LSL#2    ; Multiply by  $4*3-1 = 11$ 
ADD    Rb,Ra,Rb,LSL# 2   ; Multiply by  $4*11+1 = 45$ 

```

rather than by:

```

ADD    Rb,Ra,Ra,LSL#3    ; Multiply by 9
ADD    Rb,Rb,Rb,LSL#2    ; Multiply by  $5*9 = 45$ 

```

LOADING A WORD FROM AN UNKNOWN ALIGNMENT

		; Enter with address in Ra (32 bits) uses
		; Rb, Rc result in Rd. Note d must be less than c e.g. 0,1
BIC	Rb,Ra,#3	; Get word aligned address
LDMIA	Rb,{Rd,Rc}	; Get 64 bits containing answer
AND	Rb,Ra,#3	; Correction factor in bytes
MOVS	Rb,Rb,LSL#3	; ...now in bits and test if aligned
MOVNE	Rd,Rd,LSR Rb	; Produce bottom of result word (if not aligned)
RSBNE	Rb,Rb,#32	; Get other shift amount
ORRNE	Rd,Rd,Rc,LSL Rb	; Combine two halves to get result

NOTES

4 THUMB INSTRUCTION SET

THUMB INSTRUCTION SET FORMAT

The thumb instruction sets are 16-bit versions of ARM instruction sets (32-bit format). The ARM instructions are reduced to 16-bit versions. Thumb instructions, at the cost of versatile functions of the ARM instruction sets. The thumb instructions are decompressed to the ARM instructions by the Thumb decompressor inside the ARM920T core.

As the Thumb instructions are compressed ARM instructions, the Thumb instructions have the 16-bit format instructions and have some restrictions. The restriction by 16-bit format is fully notified for using the Thumb instructions.

FORMAT SUMMARY

The THUMB instruction set formats are shown in the following figure.

	15	14	13	12	11	10	9	8	7	6	5	4	3	2	1	0
1	0	0	0	Op	Offset5				Rs	Rd	Move Shifted register					
2	0	0	0	1	1	I	Op	Rn/offset3		Rs	Rd	Add/subtract				
3	0	0	1	Op	Rd			Offset8				Move/compare/add/ subtract immediate				
4	0	1	0	0	0	0	Op		Rs	Rd	ALU operations					
5	0	1	0	0	0	1	Op	H1	H2	Rs/Hs	Rd/Hd	Hi register operations /branch exchange				
6	0	1	0	0	1	Rd			Word8				PC-relative load			
7	0	1	0	1	L	B	0	Ro		Rb	Rd	Load/store with register offset				
8	0	1	0	1	H	S	1	Ro		Rb	Rd	Load/store sign-extended byte/halfword				
9	0	1	1	B	L	Offset5				Rb	Rd	Load/store with immediate offset				
10	1	0	0	0	L	Offset5				Rb	Rd	Load/store halfword				
11	1	0	0	1	L	Rd			Word8				SP-relative load/store			
12	1	0	1	0	SP	Rd			Word8				Load address			
13	1	0	1	1	0	0	0	0	S	SWord7				Add offset to stack pointer		
14	1	0	1	1	L	1	0	R	Rlist				Push/pop register			
15	1	1	0	0	L	Rb			Rlist				Multiple load/store			
16	1	1	0	1	Cond				Softset8				Conditional branch			
17	1	1	0	1	1	1	1	1	Value8				Software interrupt			
18	1	1	1	0	0	Offset11				Unconditional branch						
19	1	1	1	1	H	Offset				Long branch with link						
	15	14	13	12	11	10	9	8	7	6	5	4	3	2	1	0

Figure 4-1. THUMB Instruction Set Formats

OPCODE SUMMARY

The following table summarizes the THUMB instruction set. For further information about a particular instruction please refer to the sections listed in the right-most column.

Table 4-1. THUMB Instruction Set Opcodes

Mnemonic	Instruction	Lo-Register Operand	Hi-Register Operand	Condition Codes Set
ADC	Add with Carry	Y	–	Y
ADD	Add	Y	–	Y (1)
AND	AND	Y	–	Y
ASR	Arithmetic Shift Right	Y	–	Y
B	Unconditional branch	Y	–	–
Bxx	Conditional branch	Y	–	–
BIC	Bit Clear	Y	–	Y
BL	Branch and Link	–	–	–
BX	Branch and Exchange	Y	Y	–
CMN	Compare Negative	Y	–	Y
CMP	Compare	Y	Y	Y
EOR	EOR	Y	–	Y
LDMIA	Load multiple	Y	–	–
LDR	Load word	Y	–	–
LDRB	Load byte	Y	–	–
LDRH	Load halfword	Y	–	–
LSL	Logical Shift Left	Y	–	Y
LDSB	Load sign-extended byte	Y	–	–
LDSH	Load sign-extended halfword	Y	–	–
LSR	Logical Shift Right	Y	–	Y
MOV	Move register	Y	Y	Y (2)
MUL	Multiply	Y	–	Y
MVN	Move Negative register	Y	–	Y

Table 4-1. THUMB Instruction Set Opcodes (Continued)

Mnemonic	Instruction	Lo-Register Operand	Hi-Register Operand	Condition Codes Set
NEG	Negate	Y	–	Y
ORR	OR	Y	–	Y
POP	Pop register	Y	–	–
PUSH	Push register	Y	–	–
ROR	Rotate Right	Y	–	Y
SBC	Subtract with Carry	Y	–	Y
STMIA	Store Multiple	Y	–	–
STR	Store word	Y	–	–
STRB	Store byte	Y	–	–
STRH	Store halfword	Y	–	–
SWI	Software Interrupt	–	–	–
SUB	Subtract	Y	–	Y
TST	Test bits	Y	–	Y

NOTES:

1. The condition codes are unaffected by the format 5, 12 and 13 versions of this instruction.
2. The condition codes are unaffected by the format 5 version of this instruction.

FORMAT 1: MOVE SHIFTED REGISTER

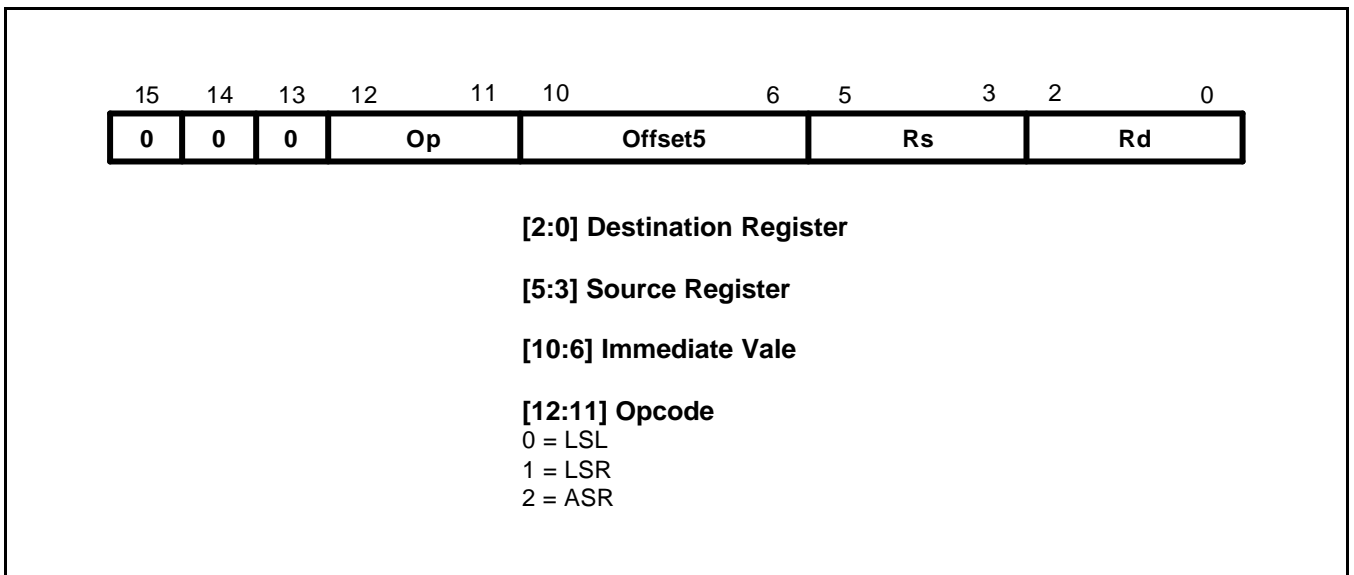

Figure 4-2. Format 1

OPERATION

These instructions move a shifted value between Lo registers. The THUMB assembler syntax is shown in Table 4-2.

NOTE

All instructions in this group set the CPSR condition codes.

Table 4-2. Summary of Format 1 Instructions

OP	THUMB Assembler	ARM Equipment	Action
00	LSL Rd, Rs, #Offset5	MOVS Rd, Rs, LSL #Offset5	Shift Rs left by a 5-bit immediate value and store the result in Rd.
01	LSR Rd, Rs, #Offset5	MOVS Rd, Rs, LSR #Offset5	Perform logical shift right on Rs by a 5-bit immediate value and store the result in Rd.
10	ASR Rd, Rs, #Offset5	MOVS Rd, Rs, ASR #Offset5	Perform arithmetic shift right on Rs by a 5-bit immediate value and store the result in Rd.

INSTRUCTION CYCLE TIMES

All instructions in this format have an equivalent ARM instruction as shown in Table 4-2. The instruction cycle times for the THUMB instruction are identical to that of the equivalent ARM instruction.

EXAMPLES

LSR R2, R5, #27

; Logical shift right the contents of R5 by 27 and store the result in R2. Set condition codes on the result.

FORMAT 2: ADD/SUBTRACT

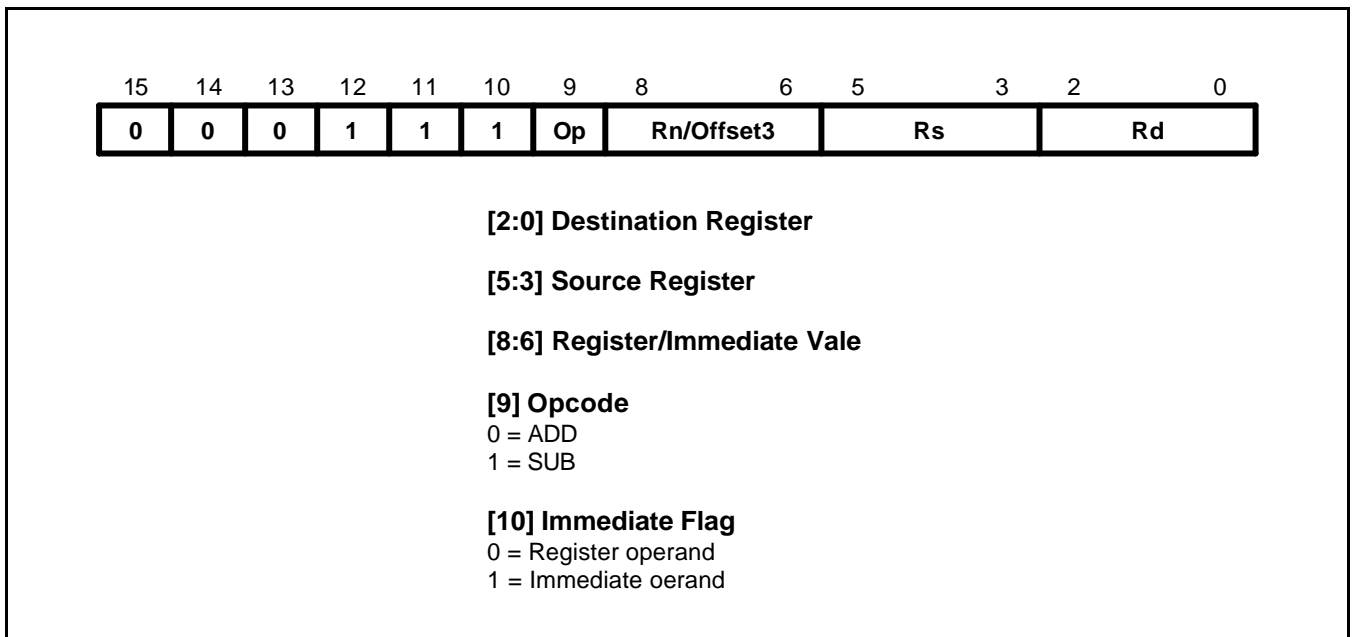

Figure 4-3. Format 2

OPERATION

These instructions allow the contents of a Lo register or a 3-bit immediate value to be added to or subtracted from a Lo register. The THUMB assembler syntax is shown in Table 4-3.

NOTE

All instructions in this group set the CPSR condition codes.

Table 4-3. Summary of Format 2 Instructions

OP	I	THUMB Assembler	ARM Equipment	Description
0	0	ADD Rd, Rs, Rn	ADDS Rd, Rs, Rn	Add contents of Rn to contents of Rs. Place result in Rd.
0	1	ADD Rd, Rs, #Offset3	ADDS Rd, Rs, #Offset3	Add 3-bit immediate value to contents of Rs. Place result in Rd.
1	0	SUB Rd, Rs, Rn	SUBS Rd, Rs, Rn	Subtract contents of Rn from contents of Rs. Place result in Rd.
1	1	SUB Rd, Rs, #Offset3	SUBS Rd, Rs, #Offset3	Subtract 3-bit immediate value from contents of Rs. Place result in Rd.

INSTRUCTION CYCLE TIMES

All instructions in this format have an equivalent ARM instruction as shown in Table 4-3. The instruction cycle times for the THUMB instruction are identical to that of the equivalent ARM instruction.

EXAMPLES

ADD	R0, R3, R4	; R0 := R3 + R4 and set condition codes on the result.
SUB	R6, R2, #6	; R6 := R2 - 6 and set condition codes.

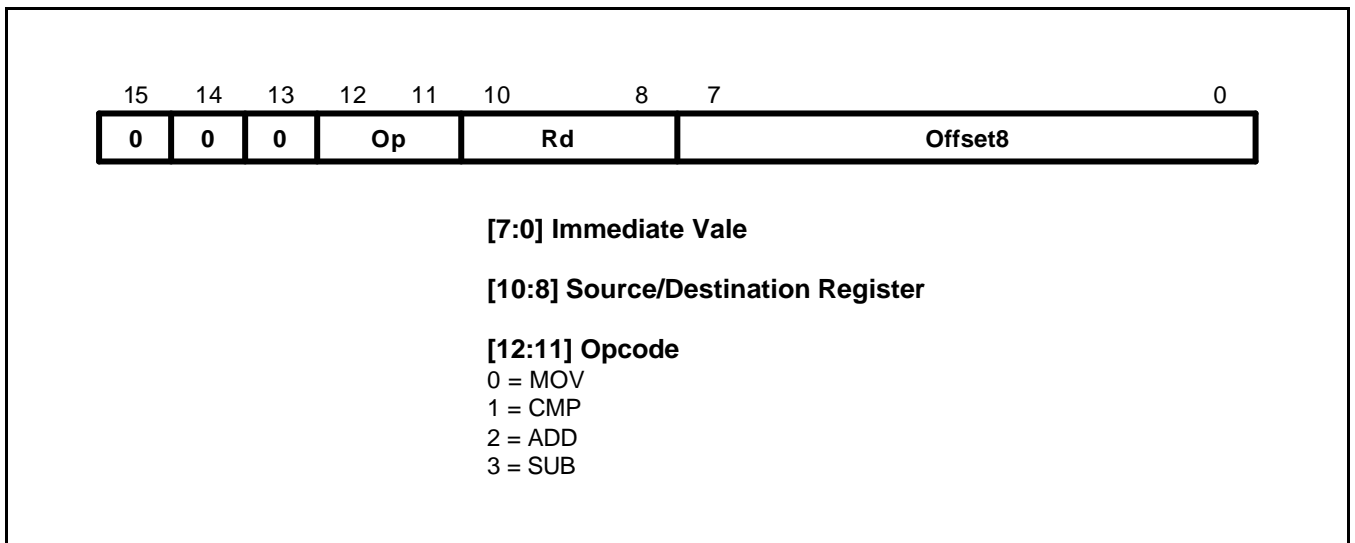
FORMAT 3: MOVE/COMPARE/ADD/SUBTRACT IMMEDIATE**Figure 4-4. Format 3****OPERATIONS**

The instructions in this group perform operations between a Lo register and an 8-bit immediate value. The THUMB assembler syntax is shown in Table 4-4.

NOTE

All instructions in this group set the CPSR condition codes.

Table 4-4. Summary of Format 3 Instructions

OP	THUMB Assembler	ARM Equipment	Description
00	MOV Rd, #Offset8	MOVS Rd, #Offset8	Move 8-bit immediate value into Rd.
01	CMP Rd, #Offset8	CMP Rd, #Offset8	Compare contents of Rd with 8-bit immediate value.
10	ADD Rd, #Offset8	ADDS Rd, Rd, #Offset8	Add 8-bit immediate value to contents of Rd and place the result in Rd.
11	SUB Rd, #Offset8	SUBS Rd, Rd, #Offset8	Subtract 8-bit immediate value from contents of Rd and place the result in Rd.

INSTRUCTION CYCLE TIMES

All instructions in this format have an equivalent ARM instruction as shown in Table 4-4. The instruction cycle times for the THUMB instruction are identical to that of the equivalent ARM instruction.

EXAMPLES

MOV	R0, #128	; R0 := 128 and set condition codes
CMP	R2, #62	; Set condition codes on R2 - 62
ADD	R1, #255	; R1 := R1 + 255 and set condition codes
SUB	R6, #145	; R6 := R6 - 145 and set condition codes

FORMAT 4: ALU OPERATIONS

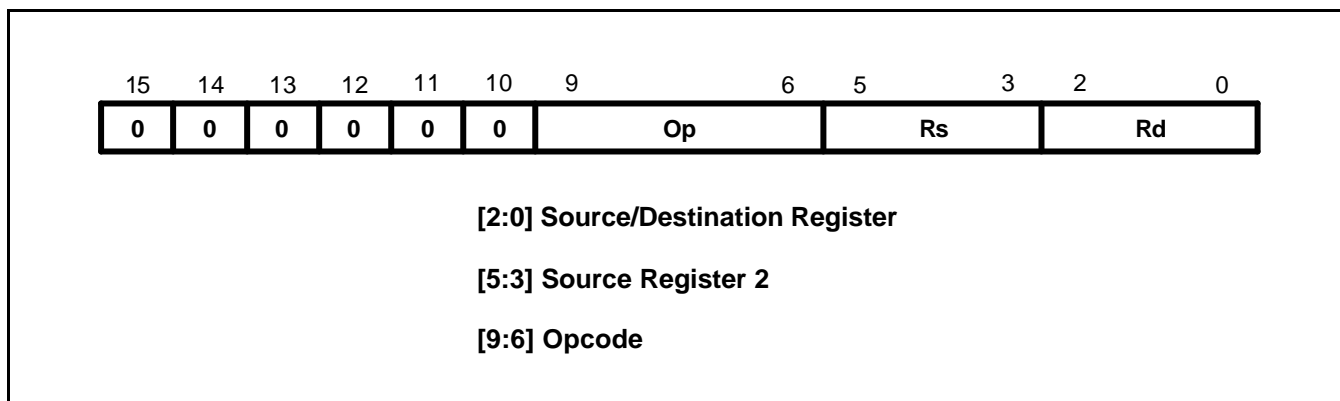

Figure 4-5. Format 4

OPERATION

The following instructions perform ALU operations on a Lo register pair.

NOTE

All instructions in this group set the CPSR condition codes.

Table 4-5. Summary of Format 4 Instructions

OP	THUMB Assembler	ARM Equipment	Description
0000	AND Rd, Rs	ANDS Rd, Rd, Rs	Rd := Rd AND Rs
0001	EOR Rd, Rs	EORS Rd, Rd, Rs	Rd := Rd EOR Rs
0010	LSL Rd, Rs	MOVS Rd, Rd, LSL Rs	Rd := Rd << Rs
0011	LSR Rd, Rs	MOVS Rd, Rd, LSR Rs	Rd := Rd >> Rs
0100	ASR Rd, Rs	MOVS Rd, Rd, ASR Rs	Rd := Rd ASR Rs
0101	ADC Rd, Rs	ADCS Rd, Rd, Rs	Rd := Rd + Rs + C-bit
0110	SBC Rd, Rs	SBCS Rd, Rd, Rs	Rd := Rd - Rs - NOT C-bit
0111	ROR Rd, Rs	MOVS Rd, Rd, ROR Rs	Rd := Rd ROR Rs
1000	TST Rd, Rs	TST Rd, Rs	Set condition codes on Rd AND Rs
1001	NEG Rd, Rs	RSBS Rd, Rs, #0	Rd = - Rs
1010	CMP Rd, Rs	CMP Rd, Rs	Set condition codes on Rd - Rs
1011	CMN Rd, Rs	CMN Rd, Rs	Set condition codes on Rd + Rs
1100	ORR Rd, Rs	ORRS Rd, Rd, Rs	Rd := Rd OR Rs
1101	MUL Rd, Rs	MULS Rd, Rs, Rd	Rd := Rs * Rd
1110	BIC Rd, Rs	BICS Rd, Rd, Rs	Rd := Rd AND NOT Rs
1111	MVN Rd, Rs	MVNS Rd, Rs	Rd := NOT Rs

INSTRUCTION CYCLE TIMES

All instructions in this format have an equivalent ARM instruction as shown in Table 4-5. The instruction cycle times for the THUMB instruction are identical to that of the equivalent ARM instruction.

EXAMPLES

EOR	R3, R4	; R3 := R3 EOR R4 and set condition codes
ROR	R1, R0	; Rotate Right R1 by the value in R0, store
		; the result in R1 and set condition codes
NEG	R5, R3	; Subtract the contents of R3 from zero,
		; Store the result in R5. Set condition codes ie R5 = - R3
CMP	R2, R6	; Set the condition codes on the result of R2 - R6
MUL	R0, R7	; R0 := R7 × R0 and set condition codes

FORMAT 5: HI-REGISTER OPERATIONS/BRANCH EXCHANGE

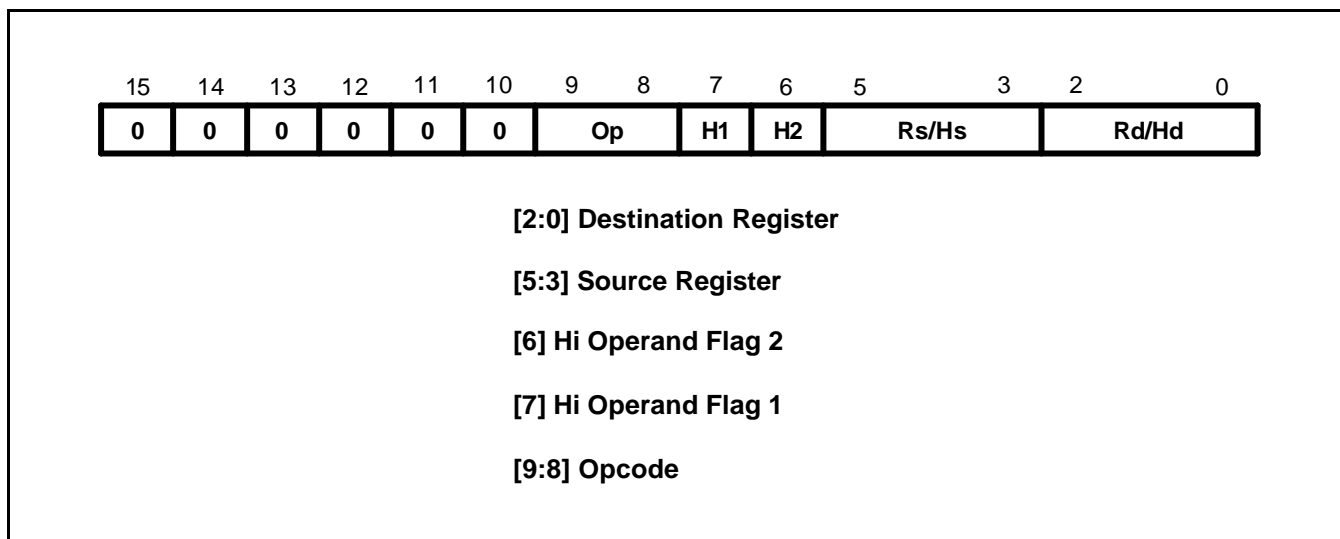

Figure 4-6. Format 5

OPERATION

There are four sets of instructions in this group. The first three allow ADD, CMP and MOV operations to be performed between Lo and Hi registers, or a pair of Hi registers. The fourth, BX, allows a Branch to be performed which may also be used to switch processor state. The THUMB assembler syntax is shown in Table 4-6.

NOTE

In this group only CMP (Op = 01) sets the CPSR condition codes.

The action of H1= 0, H2 = 0 for Op = 00 (ADD), Op =01 (CMP) and Op = 10 (MOV) is undefined, and should not be used.

Table 4-6. Summary of Format 5 Instructions

Op	H1	H2	THUMB assembler	ARM equivalent	Description
00	0	1	ADD Rd, Hs	ADD Rd, Rd, Hs	Add a register in the range 8-15 to a register in the range 0-7.
00	1	0	ADD Hd, Rs	ADD Hd, Hd, Rs	Add a register in the range 0-7 to a register in the range 8-15.
00	1	1	ADD Hd, Hs	ADD Hd, Hd, Hs	Add two registers in the range 8-15
01	0	1	CMP Rd, Hs	CMP Rd, Hs	Compare a register in the range 0-7 with a register in the range 8-15. Set the condition code flags on the result.
01	1	0	CMP Hd, Rs	CMP Hd, Rs	Compare a register in the range 8-15 with a register in the range 0-7. Set the condition code flags on the result.

Table 4-6. Summary of Format 5 Instructions (Continued)

Op	H1	H2	THUMB assembler	ARM equivalent	Description
01	1	1	CMP Hd, Hs	CMP Hd, Hs	Compare two registers in the range 8-15. Set the condition code flags on the result.
10	0	1	MOV Rd, Hs	MOV Rd, Hs	Move a value from a register in the range 8-15 to a register in the range 0-7.
10	1	0	MOV Hd, Rs	MOV Hd, Rs	Move a value from a register in the range 0-7 to a register in the range 8-15.
10	1	1	MOV Hd, Hs	MOV Hd, Hs	Move a value between two registers in the range 8-15.
11	0	0	BX Rs	BX Rs	Perform branch (plus optional state change) to address in a register in the range 0-7.
11	0	1	BX Hs	BX Hs	Perform branch (plus optional state change) to address in a register in the range 8-15.

INSTRUCTION CYCLE TIMES

All instructions in this format have an equivalent ARM instruction as shown in Table 4-6. The instruction cycle times for the THUMB instruction are identical to that of the equivalent ARM instruction.

THE BX INSTRUCTION

BX performs a Branch to a routine whose start address is specified in a Lo or Hi register.

Bit 0 of the address determines the processor state on entry to the routine:

- Bit 0 = 0 Causes the processor to enter ARM state.
- Bit 0 = 1 Causes the processor to enter THUMB state.

NOTE

The action of H1 = 1 for this instruction is undefined, and should not be used.

EXAMPLES

Hi-Register Operations

ADD	PC, R5	; PC := PC + R5 but don't set the condition codes.
CMP	R4, R12	; Set the condition codes on the result of R4 - R12.
MOV	R15, R14	; Move R14 (LR) into R15 (PC) but don't set the condition codes, eg. return from subroutine.

Branch and Exchange

ADR	R1,outofTHUMB	; Switch from THUMB to ARM state.
MOV	R11,R1	; Load address of outofTHUMB into R1.
BX	R11	; Transfer the contents of R11 into the PC.
		; Bit 0 of R11 determines whether
		; ARM or THUMB state is entered, ie. In this case the state is ARM.

ALIGN		
CODE32		
outofTHUMB		; Now processing ARM instructions...

USING R15 AS AN OPERAND

If R15 is used as an operand, the value will be the address of the instruction + 4 with bit 0 cleared. Executing a BX PC in THUMB state from a non-word aligned address will result in unpredictable execution.

FORMAT 6: PC-RELATIVE LOAD

Figure 4-7. Format 6

OPERATION

This instruction loads a word from an address specified as a 10-bit immediate offset from the PC. The THUMB assembler syntax is shown below.

Table 4-7. Summary of PC-Relative Load Instruction

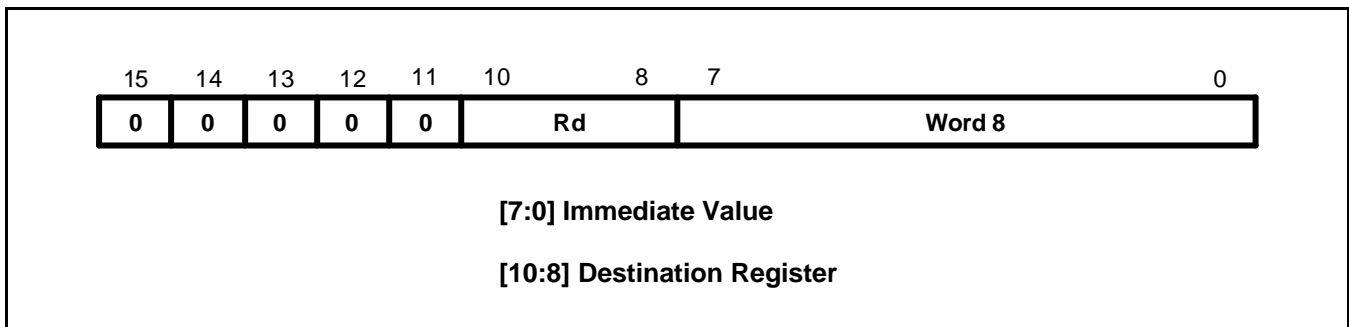
THUMB assembler	ARM equivalent	Description
LDR Rd, [PC, #Imm]	LDR Rd, [R15, #Imm]	Add unsigned offset (255 words, 1020 bytes) in Imm to the current value of the PC. Load the word from the resulting address into Rd.

NOTE: The value specified by #Imm is a full 10-bit address, but must always be word-aligned (ie with bits 1:0 set to 0), since the assembler places #Imm >> 2 in field Word 8. The value of the PC will be 4 bytes greater than the address of this instruction, but bit 1 of the PC is forced to 0 to ensure it is word aligned.

INSTRUCTION CYCLE TIMES

All instructions in this format have an equivalent ARM instruction. The instruction cycle times for the THUMB instruction are identical to that of the equivalent ARM instruction.

EXAMPLES

LDR R3,[PC,#844]

; Load into R3 the word found at the address formed by adding 844 to PC.bit[1] of PC is forced to zero. Note that the THUMB opcode will contain 211 as the Word8 value.

FORMAT 7: LOAD/STORE WITH REGISTER OFFSET

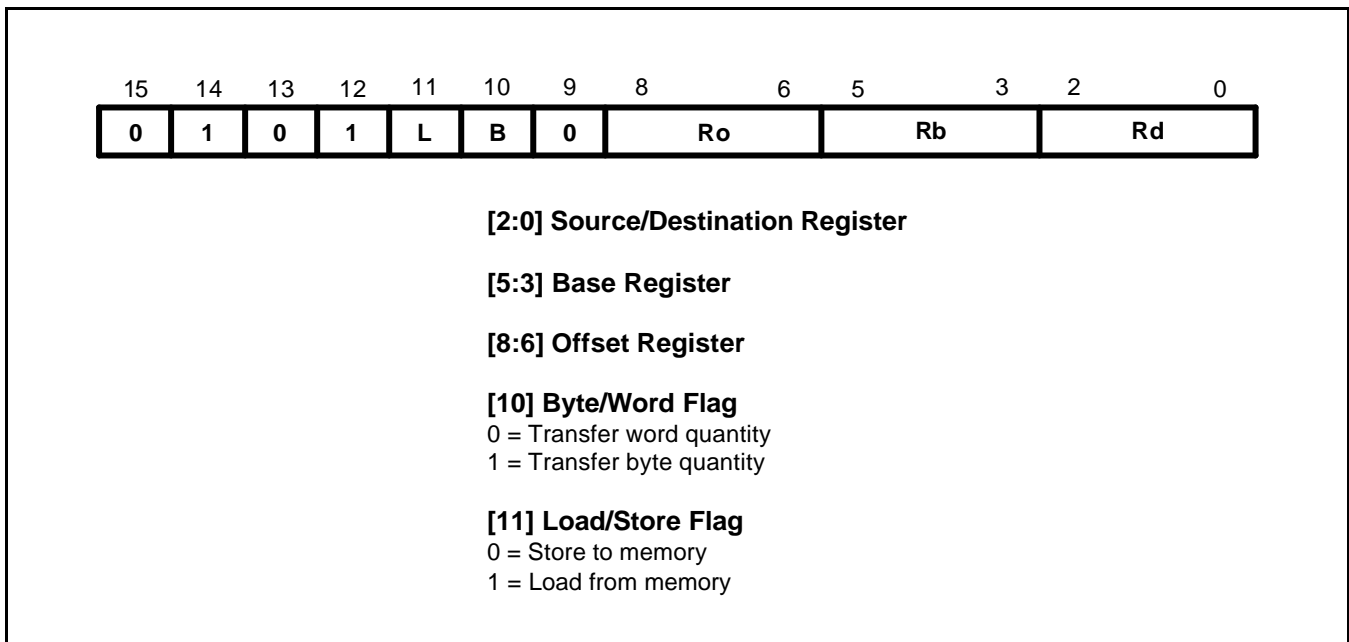

Figure 4-8. Format 7

OPERATION

These instructions transfer byte or word values between registers and memory. Memory addresses are pre-indexed using an offset register in the range 0-7. The THUMB assembler syntax is shown in Table 4-8.

Table 4-8. Summary of Format 7 Instructions

L	B	THUMB assembler	ARM equivalent	Description
0	0	STR Rd, [Rb, Ro]	STR Rd, [Rb, Ro]	Pre-indexed word store: Calculate the target address by adding together the value in Rb and the value in Ro. Store the contents of Rd at the address.
0	1	STRB Rd, [Rb, Ro]	STRB Rd, [Rb, Ro]	Pre-indexed byte store: Calculate the target address by adding together the value in Rb and the value in Ro. Store the byte value in Rd at the resulting address.
1	0	LDR Rd, [Rb, Ro]	LDR Rd, [Rb, Ro]	Pre-indexed word load: Calculate the source address by adding together the value in Rb and the value in Ro. Load the contents of the address into Rd.
1	1	LDRB Rd, [Rb, Ro]	LDRB Rd, [Rb, Ro]	Pre-indexed byte load: Calculate the source address by adding together the value in Rb and the value in Ro. Load the byte value at the resulting address.

INSTRUCTION CYCLE TIMES

All instructions in this format have an equivalent ARM instruction as shown in Table 4-8. The instruction cycle times for the THUMB instruction are identical to that of the equivalent ARM instruction.

EXAMPLES

```

STR      R3, [R2,R6]      ; Store word in R3 at the address formed by adding R6 to
                          ; R2.
LDRB    R2, [R0,R7]      ; Load into R2 the byte found at the address formed by
                          ; adding R7 to R0.

```

FORMAT 8: LOAD/STORE SIGN-EXTENDED BYTE/HALFWORD

Figure 4-9. Format 8

OPERATION

These instructions load optionally sign-extended bytes or halfwords, and store halfwords. The THUMB assembler syntax is shown below.

Table 4-9. Summary of Format 8 Instructions

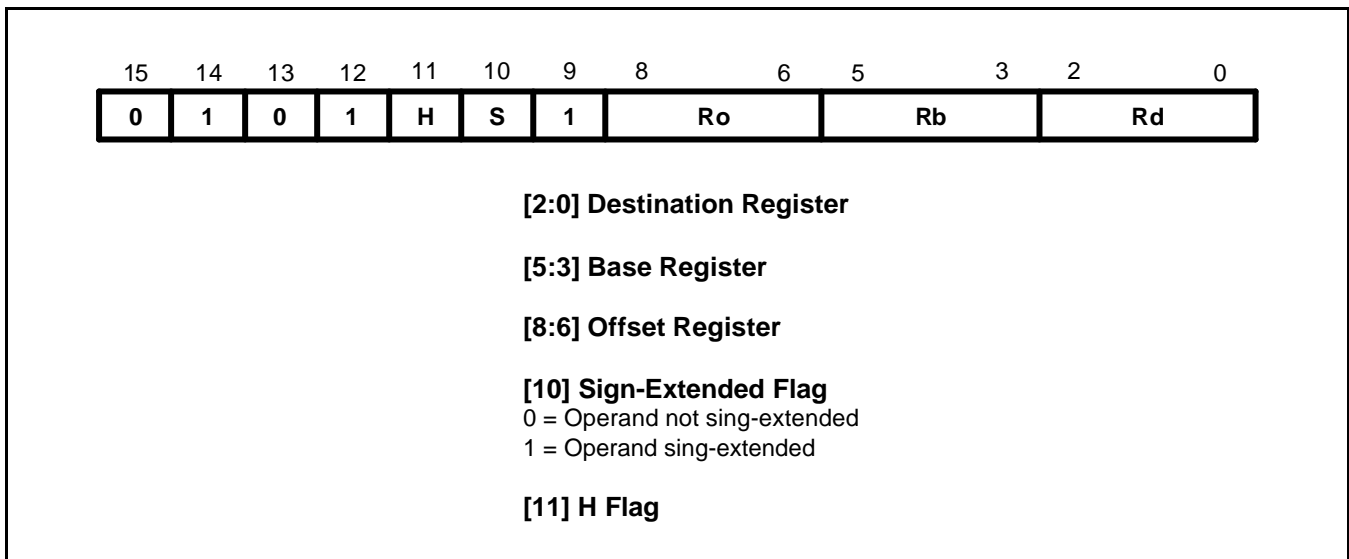
L	B	THUMB assembler	ARM equivalent	Description
0	0	STRH Rd, [Rb, Ro]	STRH Rd, [Rb, Ro]	Store halfword: Add Ro to base address in Rb. Store bits 0-15 of Rd at the resulting address.
0	1	LDRH Rd, [Rb, Ro]	LDRH Rd, [Rb, Ro]	Load halfword: Add Ro to base address in Rb. Load bits 0-15 of Rd from the resulting address, and set bits 16-31 of Rd to 0.
1	0	LDSB Rd, [Rb, Ro]	LDRSB Rd, [Rb, Ro]	Load sign-extended byte: Add Ro to base address in Rb. Load bits 0-7 of Rd from the resulting address, and set bits 8-31 of Rd to bit 7.
1	1	LDSH Rd, [Rb, Ro]	LDRSH Rd, [Rb, Ro]	Load sign-extended halfword: Add Ro to base address in Rb. Load bits 0-15 of Rd from the resulting address, and set bits 16-31 of Rd to bit 15.

INSTRUCTION CYCLE TIMES

All instructions in this format have an equivalent ARM instruction as shown in Table 4-9. The instruction cycle times for the THUMB instruction are identical to that of the equivalent ARM instruction.

EXAMPLES

STRH	R4, [R3, R0]	; Store the lower 16 bits of R4 at the address formed by adding R0 to R3.
LDSB	R2, [R7, R1]	; Load into R2 the sign extended byte found at the address formed by adding R1 to R7.
LDSH	R3, [R4, R2]	; Load into R3 the sign extended halfword found at the address formed by adding R2 to R4.

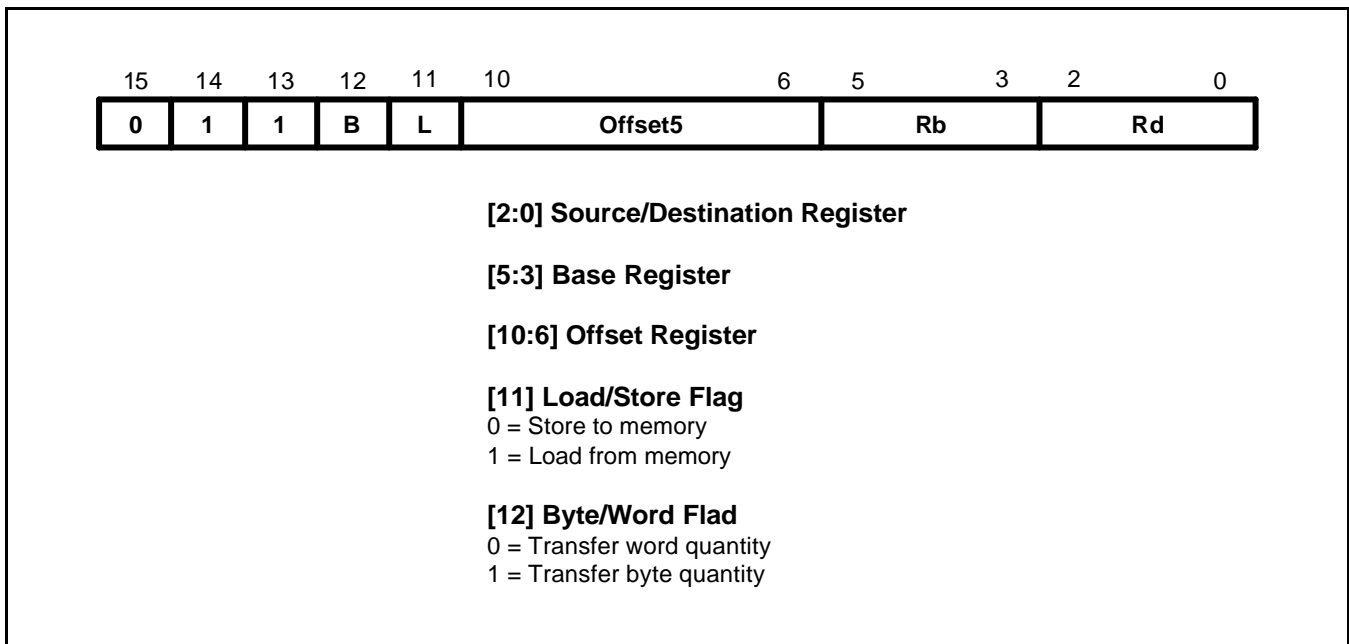
FORMAT 9: LOAD/STORE WITH IMMEDIATE OFFSET**Figure 4-10. Format 9**

OPERATION

These instructions transfer byte or word values between registers and memory using an immediate 5 or 7-bit offset. The THUMB assembler syntax is shown in Table 4-10.

Table 4-10. Summary of Format 9 Instructions

L	B	THUMB assembler	ARM equivalent	Description
0	0	STR Rd, [Rb, #Imm]	STR Rd, [Rb, #Imm]	Calculate the target address by adding together the value in Rb and Imm. Store the contents of Rd at the address.
1	0	LDR Rd, [Rb, #Imm]	LDR Rd, [Rb, #Imm]	Calculate the source address by adding together the value in Rb and Imm. Load Rd from the address.
0	1	STRB Rd, [Rb, #Imm]	STRB Rd, [Rb, #Imm]	Calculate the target address by adding together the value in Rb and Imm. Store the byte value in Rd at the address.
1	1	LDRB Rd, [Rb, #Imm]	LDRB Rd, [Rb, #Imm]	Calculate source address by adding together the value in Rb and Imm. Load the byte value at the address into Rd.

NOTE: For word accesses (B = 0), the value specified by #Imm is a full 7-bit address, but must be word-aligned (ie with bits 1:0 set to 0), since the assembler places #Imm >> 2 in the Offset5 field.

INSTRUCTION CYCLE TIMES

All instructions in this format have an equivalent ARM instruction as shown in Table 4-10. The instruction cycle times for the THUMB instruction are identical to that of the equivalent ARM instruction.

EXAMPLES

LDR R2, [R5,#116] ; Load into R2 the word found at the address formed by adding 116 to R5. Note that the THUMB opcode will contain 29 as the Offset5 value.

STRB R1, [R0,#13] ; Store the lower 8 bits of R1 at the address formed by adding 13 to R0. Note that the THUMB opcode will contain 13 as the Offset5 value.

FORMAT 10: LOAD/STORE HALFWORD

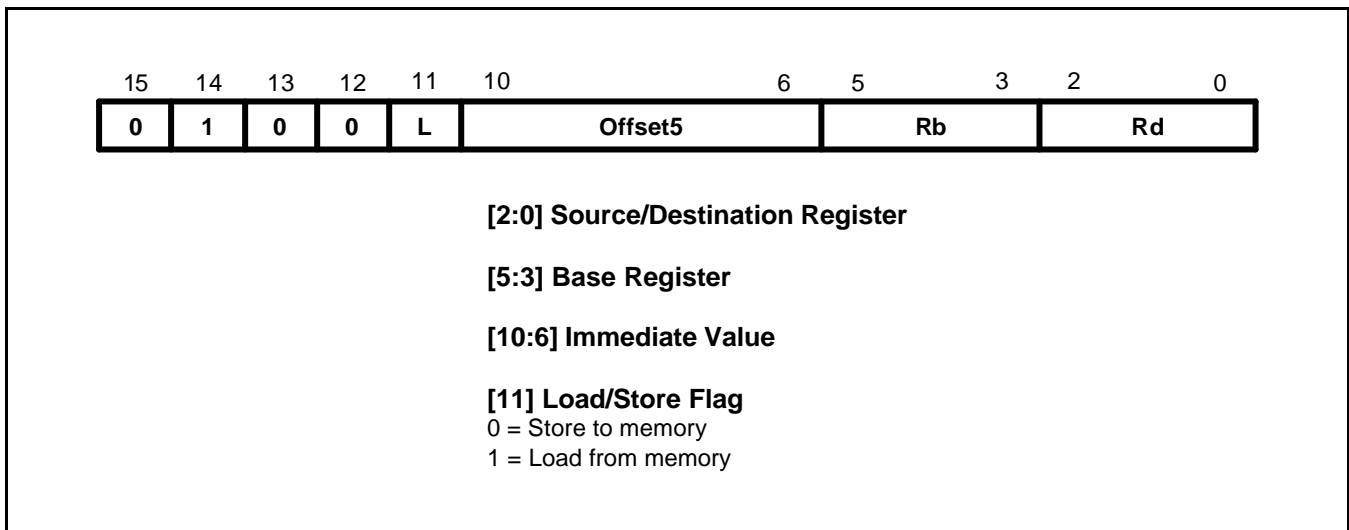

Figure 4-11. Format 10

OPERATION

These instructions transfer halfword values between a Lo register and memory. Addresses are pre-indexed, using a 6-bit immediate value. The THUMB assembler syntax is shown in Table 4-11.

Table 4-11. Halfword Data Transfer Instructions

L	THUMB assembler	ARM equivalent	Description
0	STRH Rd, [Rb, #Imm]	STRH Rd, [Rb, #Imm]	Add #Imm to base address in Rb and store bits 0 - 15 of Rd at the resulting address.
1	LDRH Rd, [Rb, #Imm]	LDRH Rd, [Rb, #Imm]	Add #Imm to base address in Rb. Load bits 0-15 from the resulting address into Rd and set bits 16-31 to zero.

NOTE: #Imm is a full 6-bit address but must be halfword-aligned (ie with bit 0 set to 0) since the assembler places #Imm >> 1 in the Offset5 field.

INSTRUCTION CYCLE TIMES

All instructions in this format have an equivalent ARM instruction as shown in Table 4-11. The instruction cycle times for the THUMB instruction are identical to that of the equivalent ARM instruction.

EXAMPLES

STRH	R6, [R1, #56]	; Store the lower 16 bits of R4 at the address formed by adding 56 R1. Note that the THUMB opcode will contain 28 as the Offset5 value.
LDRH	R4, [R7, #4]	; Load into R4 the halfword found at the address formed by adding 4 to R7. Note that the THUMB opcode will contain 2 as the Offset5 value.

FORMAT 11: SP-RELATIVE LOAD/STORE

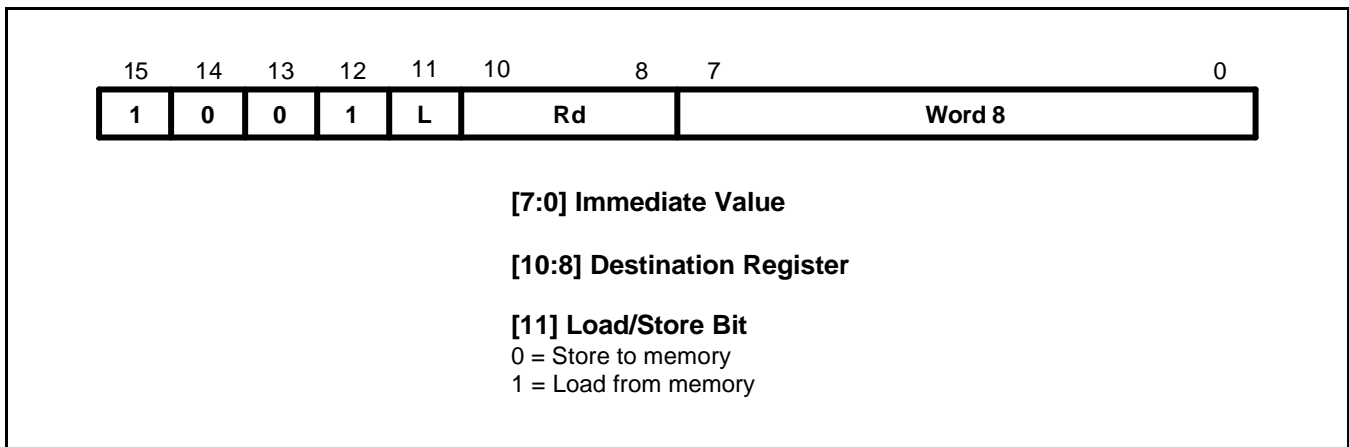

Figure 4-12. Format 11

OPERATION

The instructions in this group perform an SP-relative load or store. The THUMB assembler syntax is shown in the following table.

Table 4-12. SP-Relative Load/Store Instructions

L	THUMB assembler	ARM equivalent	Description
0	STR Rd, [SP, #Imm]	STR Rd, [R13 #Imm]	Add unsigned offset (255 words, 1020 bytes) in Imm to the current value of the SP (R7). Store the contents of Rd at the resulting address.
1	LDR Rd, [SP, #Imm]	LDR Rd, [R13 #Imm]	Add unsigned offset (255 words, 1020 bytes) in Imm to the current value of the SP (R7). Load the word from the resulting address into Rd.

NOTE: The offset supplied in #Imm is a full 10-bit address, but must always be word-aligned (ie bits 1:0 set to 0), since the assembler places #Imm >> 2 in the Word8 field.

INSTRUCTION CYCLE TIMES

All instructions in this format have an equivalent ARM instruction as shown in Table 4-12. The instruction cycle times for the THUMB instruction are identical to that of the equivalent ARM instruction.

EXAMPLES

STR R4, [SP,#492] ; Store the contents of R4 at the address formed by adding 492 to SP (R13). Note that the THUMB opcode will contain 123 as the Word8 value.

FORMAT 12: LOAD ADDRESS

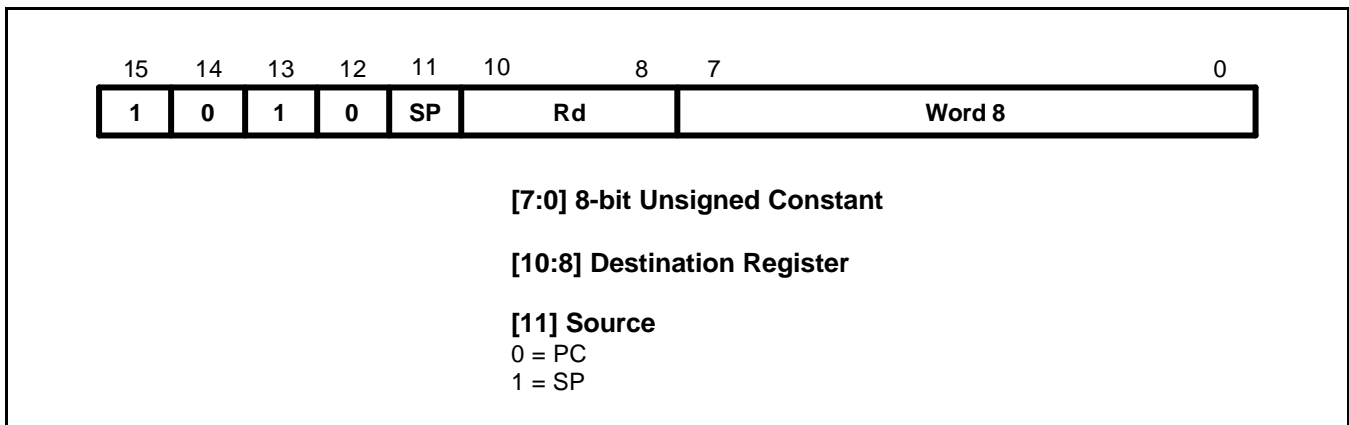

Figure 4-13. Format 12

OPERATION

These instructions calculate an address by adding a 10-bit constant to either the PC or the SP, and load the resulting address into a register. The THUMB assembler syntax is shown in the following table.

Table 4-13. Load Address

L	THUMB assembler	ARM equivalent	Description
0	ADD Rd, PC, #Imm	ADD Rd, R15, #Imm	Add #Imm to the current value of the program counter (PC) and load the result into Rd.
1	ADD Rd, SP, #Imm	ADD Rd, R13, #Imm	Add #Imm to the current value of the stack pointer (SP) and load the result into Rd.

NOTE: The value specified by #Imm is a full 10-bit value, but this must be word-aligned (ie with bits 1:0 set to 0) since the assembler places #Imm >> 2 in field Word 8.

Where the PC is used as the source register (SP = 0), bit 1 of the PC is always read as 0. The value of the PC will be 4 bytes greater than the address of the instruction before bit 1 is forced to 0.

The CPSR condition codes are unaffected by these instructions.

INSTRUCTION CYCLE TIMES

All instructions in this format have an equivalent ARM instruction as shown in Table 4-13. The instruction cycle times for the THUMB instruction are identical to that of the equivalent ARM instruction.

EXAMPLES

ADD	R2, PC, #572	; R2 := PC + 572, but don't set the condition codes. bit[1] of PC is forced to zero. Note that the THUMB opcode will contain 143 as the Word8 value.
ADD	R6, SP, #212	; R6 := SP (R13) + 212, but don't set the condition codes. Note that the THUMB opcode will contain 53 as the Word 8 value.

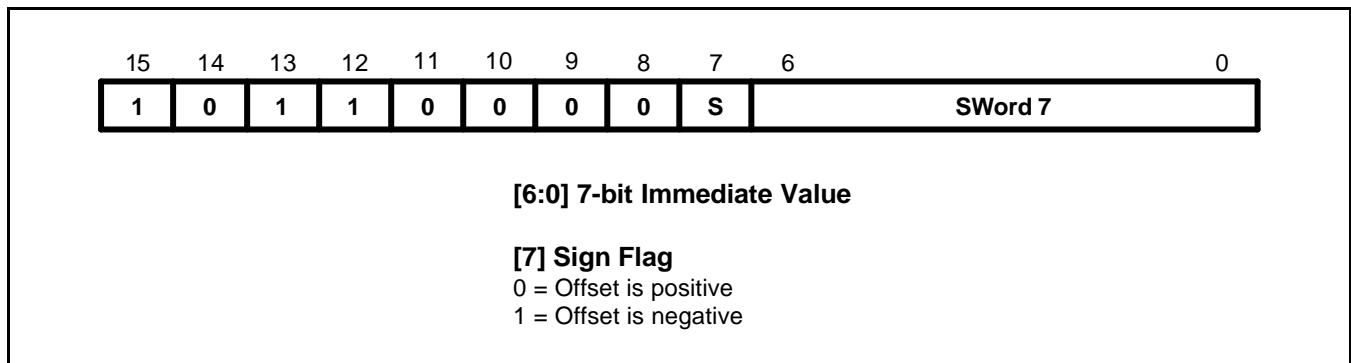
FORMAT 13: ADD OFFSET TO STACK POINTER**Figure 4-14. Format 13****OPERATION**

This instruction adds a 9-bit signed constant to the stack pointer. The following table shows the THUMB assembler syntax.

Table 4-14. The ADD SP Instruction

L	THUMB assembler	ARM equivalent	Description
0	ADD SP, #Imm	ADD R13, R13, #Imm	Add #Imm to the stack pointer (SP).
1	ADD SP, # -Imm	SUB R13, R13, #Imm	Add #-Imm to the stack pointer (SP).

NOTE: The offset specified by #Imm can be up to +/- 508, but must be word-aligned (ie with bits 1:0 set to 0) since the assembler converts #Imm to an 8-bit sign + magnitude number before placing it in field SWord7. The condition codes are not set by this instruction.

INSTRUCTION CYCLE TIMES

All instructions in this format have an equivalent ARM instruction as shown in Table 4-14. The instruction cycle times for the THUMB instruction are identical to that of the equivalent ARM instruction.

EXAMPLES

ADD	SP, #268	;	SP (R13) := SP + 268, but don't set the condition codes. Note that the THUMB opcode will contain 67 as the Word7 value and S=0.
ADD	SP, #-104	;	SP (R13) := SP - 104, but don't set the condition codes. Note that the THUMB opcode will contain 26 as the Word7 value and S=1.

INSTRUCTION CYCLE TIMES

All instructions in this format have an equivalent ARM instruction as shown in Table 4-15. The instruction cycle times for the THUMB instruction are identical to that of the equivalent ARM instruction.

EXAMPLES

PUSH	{R0-R4,LR}	; Store R0,R1,R2,R3,R4 and R14 (LR) at the stack pointed to by R13 (SP) and update R13. Useful at start of a sub-routine to save workspace and return address.
POP	{R2,R6,PC}	; Load R2,R6 and R15 (PC) from the stack pointed to by R13 (SP) and update R13. Useful to restore workspace and return from sub-routine.

FORMAT 15: MULTIPLE LOAD/STORE

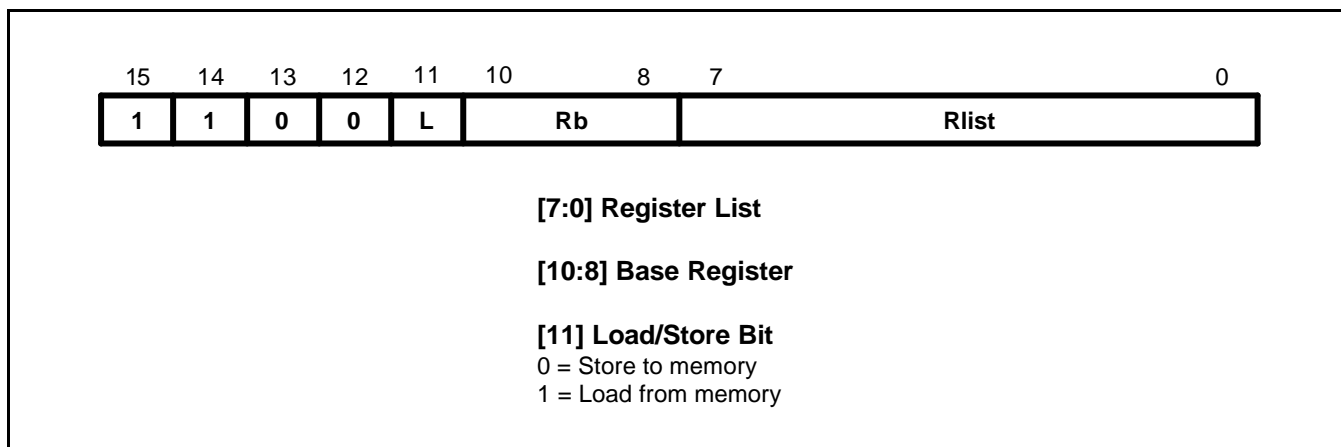

Figure 4-16. Format 15

OPERATION

These instructions allow multiple loading and storing of Lo registers. The THUMB assembler syntax is shown in the following table.

Table 4-16. The Multiple Load/Store Instructions

L	THUMB assembler	ARM equivalent	Description
0	STMIA Rb!, { Rlist }	STMIA Rb!, { Rlist }	Store the registers specified by Rlist, starting at the base address in Rb. Write back the new base address.
1	LDMIA Rb!, { Rlist }	LDMIA Rb!, { Rlist }	Load the registers specified by Rlist, starting at the base address in Rb. Write back the new base address.

INSTRUCTION CYCLE TIMES

All instructions in this format have an equivalent ARM instruction as shown in Table 4-16. The instruction cycle times for the THUMB instruction are identical to that of the equivalent ARM instruction.

EXAMPLES

STMIA R0!, {R3-R7} ; Store the contents of registers R3-R7 starting at the address specified in R0, incrementing the addresses for each word. Write back the updated value of R0.

FORMAT 16: CONDITIONAL BRANCH

Figure 4-17. Format 16

OPERATION

The instructions in this group all perform a conditional Branch depending on the state of the CPSR condition codes. The branch offset must take account of the prefetch operation, which causes the PC to be 1 word (4 bytes) ahead of the current instruction.

The THUMB assembler syntax is shown in the following table.

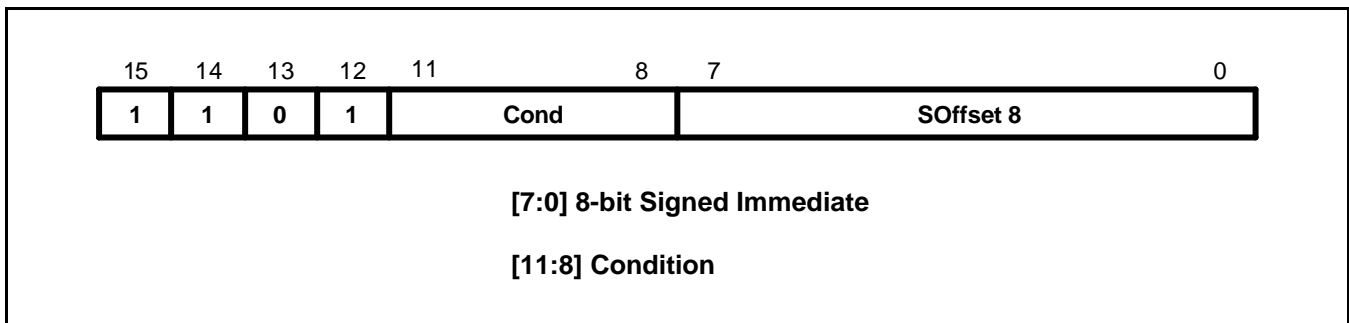
Table 4-17. The Conditional Branch Instructions

L	THUMB assembler	ARM equivalent	Description
0000	BEQ label	BEQ label	Branch if Z set (equal)
0001	BNE label	BNE label	Branch if Z clear (not equal)
0010	BCS label	BCS label	Branch if C set (unsigned higher or same)
0011	BCC label	BCC label	Branch if C clear (unsigned lower)
0100	BMI label	BMI label	Branch if N set (negative)
0101	BPL label	BPL label	Branch if N clear (positive or zero)
0110	BVS label	BVS label	Branch if V set (overflow)
0111	BVC label	BVC label	Branch if V clear (no overflow)
1000	BHI label	BHI label	Branch if C set and Z clear (unsigned higher)

Table 4-17. The Conditional Branch Instructions (Continued)

L	THUMB assembler	ARM equivalent	Description
1001	BLS label	BLS label	Branch if C clear or Z set (unsigned lower or same)
1010	BGE label	BGE label	Branch if N set and V set, or N clear and V clear (greater or equal)
1011	BLT label	BLT label	Branch if N set and V clear, or N clear and V set (less than)
1100	BGT label	BGT label	Branch if Z clear, and either N set and V set or N clear and V clear (greater than)
1101	BLE label	BLE label	Branch if Z set, or N set and V clear, or N clear and V set (less than or equal)

NOTES:

1. While label specifies a full 9-bit two's complement address, this must always be halfword-aligned (ie with bit 0 set to 0) since the assembler actually places label >> 1 in field SOffset8.
2. Cond = 1110 is undefined, and should not be used.
Cond = 1111 creates the SWI instruction: see.

INSTRUCTION CYCLE TIMES

All instructions in this format have an equivalent ARM instruction as shown in Table 3-1. The instruction cycle times for the THUMB instruction are identical to that of the equivalent ARM instruction.

EXAMPLES

```

CMP R0, #45           ; Branch to over-if R0 > 45.
BGT over             ; Note that the THUMB opcode will contain the number of
                    ; halfwords to offset.
over                 ; Must be halfword aligned.

```

FORMAT 17: SOFTWARE INTERRUPT

Figure 4-18. Format 17

OPERATION

The SWI instruction performs a software interrupt. On taking the SWI, the processor switches into ARM state and enters Supervisor (SVC) mode.

The THUMB assembler syntax for this instruction is shown below.

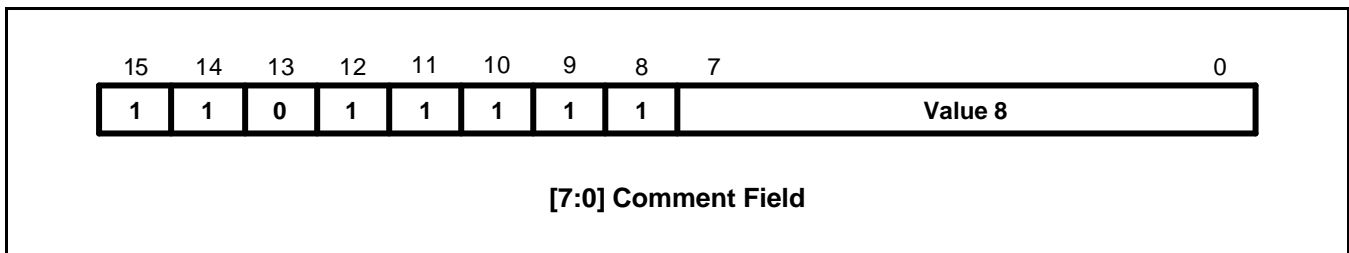
Table 4-18. The SWI Instruction

THUMB assembler	ARM equivalent	Description
SWI Value 8	SWI Value 8	Perform Software Interrupt: Move the address of the next instruction into LR, move CPSR to SPSR, load the SWI vector address (0x8) into the PC. Switch to ARM state and enter SVC mode.

NOTE: Value8 is used solely by the SWI handler; it is ignored by the processor.

INSTRUCTION CYCLE TIMES

All instructions in this format have an equivalent ARM instruction as shown in Table 4-18. The instruction cycle times for the THUMB instruction are identical to that of the equivalent ARM instruction.

EXAMPLES

SWI 18 ; Take the software interrupt exception. Enter Supervisor mode with 18 as the requested SWI number.

FORMAT 18: UNCONDITIONAL BRANCH

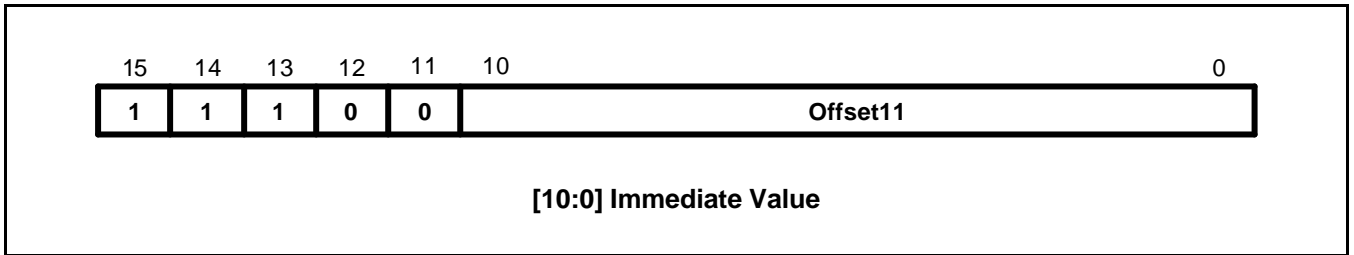

Figure 4-19. Format 18

OPERATION

This instruction performs a PC-relative Branch. The THUMB assembler syntax is shown below. The branch offset must take account of the prefetch operation, which causes the PC to be 1 word (4 bytes) ahead of the current instruction.

Table 4-19. Summary of Branch Instruction

THUMB assembler	ARM equivalent	Description
B label	BAL label (halfword offset)	Branch PC relative \pm Offset11 \ll 1, where label is PC \pm 2048 bytes.

NOTE: The address specified by label is a full 12-bit two's complement address, but must always be halfword aligned (ie bit 0 set to 0), since the assembler places label \gg 1 in the Offset11 field.

EXAMPLES

```

here      B here          ; Branch onto itself. Assembles to 0xE7FE.
           ; (Note effect of PC offset).
           B jimmy       ; Branch to 'jimmy'.
           •             ; Note that the THUMB opcode will contain the number of
           •             ; halfwords to offset.
           •             ; Must be halfword aligned.
jimmy     •
    
```

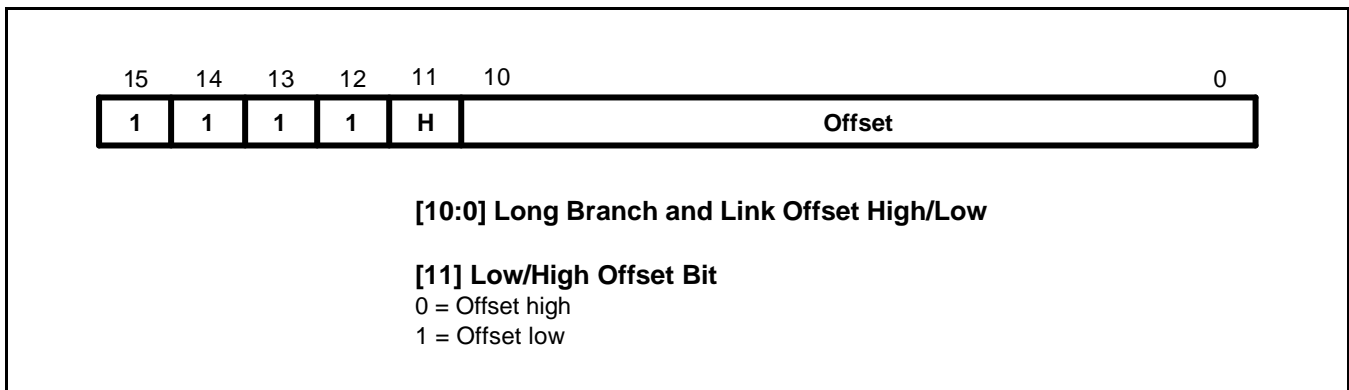
FORMAT 19: LONG BRANCH WITH LINK**Figure 4-20. Format 19****OPERATION**

This format specifies a long branch with link.

The assembler splits the 23-bit two's complement half-word offset specified by the label into two 11-bit halves, ignoring bit 0 (which must be 0), and creates two THUMB instructions.

Instruction 1 (H = 0)

In the first instruction the Offset field contains the upper 11 bits of the target address. This is shifted left by 12 bits and added to the current PC address. The resulting address is placed in LR.

Instruction 2 (H =1)

In the second instruction the Offset field contains an 11-bit representation lower half of the target address. This is shifted left by 1 bit and added to LR. LR, which now contains the full 23-bit address, is placed in PC, the address of the instruction following the BL is placed in LR and bit 0 of LR is set.

The branch offset must take account of the prefetch operation, which causes the PC to be 1 word (4 bytes) ahead of the current instruction

INSTRUCTION CYCLE TIMES

This instruction format does not have an equivalent ARM instruction.

Table 4-20. The BL Instruction

L	THUMB assembler	ARM equivalent	Description
0	BL label	none	LR := PC + OffsetHigh << 12
1			temp := next instruction address PC := LR + OffsetLow << 1 LR := temp 1

EXAMPLES

```

next      BL faraway          ; Unconditionally Branch to 'faraway'
          •                  and place following instruction
          •                  address, ie "next", in R14,the Link register and set bit 0 of
                                LR high.
                                Note that the THUMB opcodes will contain the number of
                                halfwords to offset.
faraway   •                  ; Must be Half-word aligned.
          •

```

INSTRUCTION SET EXAMPLES

The following examples show ways in which the THUMB instructions may be used to generate small and efficient code. Each example also shows the ARM equivalent so these may be compared.

MULTIPLICATION BY A CONSTANT USING SHIFTS AND ADDS

The following instructions are the code to multiply by various constants using 1, 2 or 3 Thumb instructions alongside the ARM equivalents. For other constants it is generally better to use the built-in MUL instruction rather than using a sequence of 4 or more instructions.

Thumb	ARM
1. Multiplication by 2^n (1,2,4,8,...)	
LSL	Ra, Rb, LSL #n ; MOV Ra, Rb, LSL #n
2. Multiplication by 2^{n+1} (3,5,9,17,...)	
LSL	Rt, Rb, #n ; ADD Ra, Rb, Rb, LSL #n
ADD	Ra, Rt, Rb
3. Multiplication by 2^{n-1} (3,7,15,...)	
LSL	Rt, Rb, #n ; RSB Ra, Rb, Rb, LSL #n
SUB	Ra, Rt, Rb
4. Multiplication by -2^n (-2, -4, -8, ...)	
LSL	Ra, Rb, #n ; MOV Ra, Rb, LSL #n
MVN	Ra, Ra ; RSB Ra, Ra, #0
5. Multiplication by -2^{n-1} (-3, -7, -15, ...)	
LSL	Rt, Rb, #n ; SUB Ra, Rb, Rb, LSL #n
SUB	Ra, Rb, Rt

Multiplication by any $C = \{2^{n+1}, 2^{n-1}, -2^n \text{ or } -2^{n-1}\} * 2^n$

Effectively this is any of the multiplications in 2 to 5 followed by a final shift. This allows the following additional constants to be multiplied. 6, 10, 12, 14, 18, 20, 24, 28, 30, 34, 36, 40, 48, 56, 60, 62

(2..5)	; (2..5)
LSL	Ra, Ra, #n ; MOV Ra, Ra, LSL #n

GENERAL PURPOSE SIGNED DIVIDE

This example shows a general purpose signed divide and remainder routine in both Thumb and ARM code.

Thumb code

```
;signed_divide                                ; Signed divide of R1 by R0: returns quotient in R0,
                                                ; remainder in R1
```

```
;Get abs value of R0 into R3
```

```
ASR      R2, R0, #31          ; Get 0 or -1 in R2 depending on sign of R0
EOR      R0, R2              ; EOR with -1 (0xFFFFFFFF) if negative
SUB      R3, R0, R2          ; and ADD 1 (SUB -1) to get abs value
```

```
;SUB always sets flag so go & report division by 0 if necessary
```

```
BEQ      divide_by_zero
```

```
;Get abs value of R1 by xoring with 0xFFFFFFFF and adding 1 if negative
```

```
ASR      R0, R1, #31          ; Get 0 or -1 in R3 depending on sign of R1
EOR      R1, R0              ; EOR with -1 (0xFFFFFFFF) if negative
SUB      R1, R0              ; and ADD 1 (SUB -1) to get abs value
```

```
;Save signs (0 or -1 in R0 & R2) for later use in determining ; sign of quotient & remainder.
```

```
PUSH     {R0, R2}
```

```
;Justification, shift 1 bit at a time until divisor (R0 value) ; is just <= than dividend (R1 value). To do this shift dividend
; right by 1 and stop as soon as shifted value becomes >.
```

```
LSR      R0, R1, #1
MOV      R2, R3
B        %FT0
just_l   LSL      R2, #1
0        CMP      R2, R0
        BLS      just_l
        MOV      R0, #0          ; Set accumulator to 0
        B        %FT0          ; Branch into division loop
div_l    LSR      R2, #1
0        CMP      R1, R2          ; Test subtract
        BCC      %FT0
        SUB      R1, R2          ; If successful do a real subtract
0        ADC      R0, R0          ; Shift result and add 1 if subtract succeeded
        CMP      R2, R3          ; Terminate when R2 == R3 (ie we have just
        BNE      div_l          ; tested subtracting the 'ones' value).
```

Now fix up the signs of the quotient (R0) and remainder (R1)

```

POP      {R2, R3}          ; Get dividend/divisor signs back
EOR      R3, R2            ; Result sign
EOR      R0, R3            ; Negate if result sign = - 1
SUB      R0, R3
EOR      R1, R2            ; Negate remainder if dividend sign = - 1
SUB      R1, R2
MOV      pc, lr

```

ARM Code

```

signed_divide      ; Effectively zero a4 as top bit will be shifted out later
ANDS      a4, a1, #0x80000000
RSBMI     a1, a1, #0
EORS      ip, a4, a2, ASR #32

```

;ip bit 31 = sign of result

;ip bit 30 = sign of a2

```
RSBPCS     a2, a2, #0
```

;Central part is identical code to udiv (without MOV a4, #0 which comes for free as part of signed entry sequence)

```

MOV      a3, a1
BEQ      divide_by_zero
just_l   ; Justification stage shifts 1 bit at a time
CMP      a3, a2, LSR #1
MOVLS    a3, a3, LSL #1      ; NB: LSL #1 is always OK if LS succeeds
BLO      s_loop
div_l
CMP      a2, a3
ADC      a4, a4, a4
SUBCS    a2, a2, a3
TEQ      a3, a1
MOVNE    a3, a3, LSR #1
BNE      s_loop2
MOV      a1, a4
MOV      ip, ip, ASL #1
RSBPCS   a1, a1, #0
RSBMI    a2, a2, #0
ce
MOV      pc, lr

```

DIVISION BY A CONSTANT

Division by a constant can often be performed by a short fixed sequence of shifts, adds and subtracts.

Here is an example of a divide by 10 routine based on the algorithm in the ARM Cookbook in both Thumb and ARM code.

Thumb Code

```

udiv10                                ; Take argument in a1 returns quotient in a1,
                                        ; remainder in a2
    MOV     a2, a1
    LSR     a3, a1, #2
    SUB     a1, a3
    LSR     a3, a1, #4
    ADD     a1, a3
    LSR     a3, a1, #8
    ADD     a1, a3
    LSR     a3, a1, #16
    ADD     a1, a3
    LSR     a1, #3
    ASL     a3, a1, #2
    ADD     a3, a1
    ASL     a3, #1
    SUB     a2, a3
    CMP     a2, #10
    BLT     %FT0
    ADD     a1, #1
    SUB     a2, #10
0
    MOV     pc, lr

```

ARM Code

```

udiv10                                ; Take argument in a1 returns quotient in a1,
                                        ; remainder in a2
    SUB     a2, a1, #10
    SUB     a1, a1, a1, lsr #2
    ADD     a1, a1, a1, lsr #4
    ADD     a1, a1, a1, lsr #8
    ADD     a1, a1, a1, lsr #16
    MOV     a1, a1, lsr #3
    ADD     a3, a1, a1, asl #2
    SUBS    a2, a2, a3, asl #1
    ADDPL   a1, a1, #1
    ADDMI   a2, a2, #10
    MOV     pc, lr

```

NOTES

5 MEMORY CONTROLLER

OVERVIEW

The S3C2440A memory controller provides memory control signals that are required for external memory access.

The S3C2440A has the following features:

- Little/Big endian (selectable by a software)
- Address space: 128Mbytes per bank (total 1GB/8 banks)
- Programmable access size (8/16/32-bit) for all banks except bank0 (16/32-bit)
- Total 8 memory banks
 - Six memory banks for ROM, SRAM, etc.
 - Remaining two memory banks for ROM, SRAM, SDRAM, etc .
- Seven fixed memory bank start address
- One flexible memory bank start address and programmable bank size
- Programmable access cycles for all memory banks
- External wait to extend the bus cycles
- Supporting self-refresh and power down mode in SDRAM

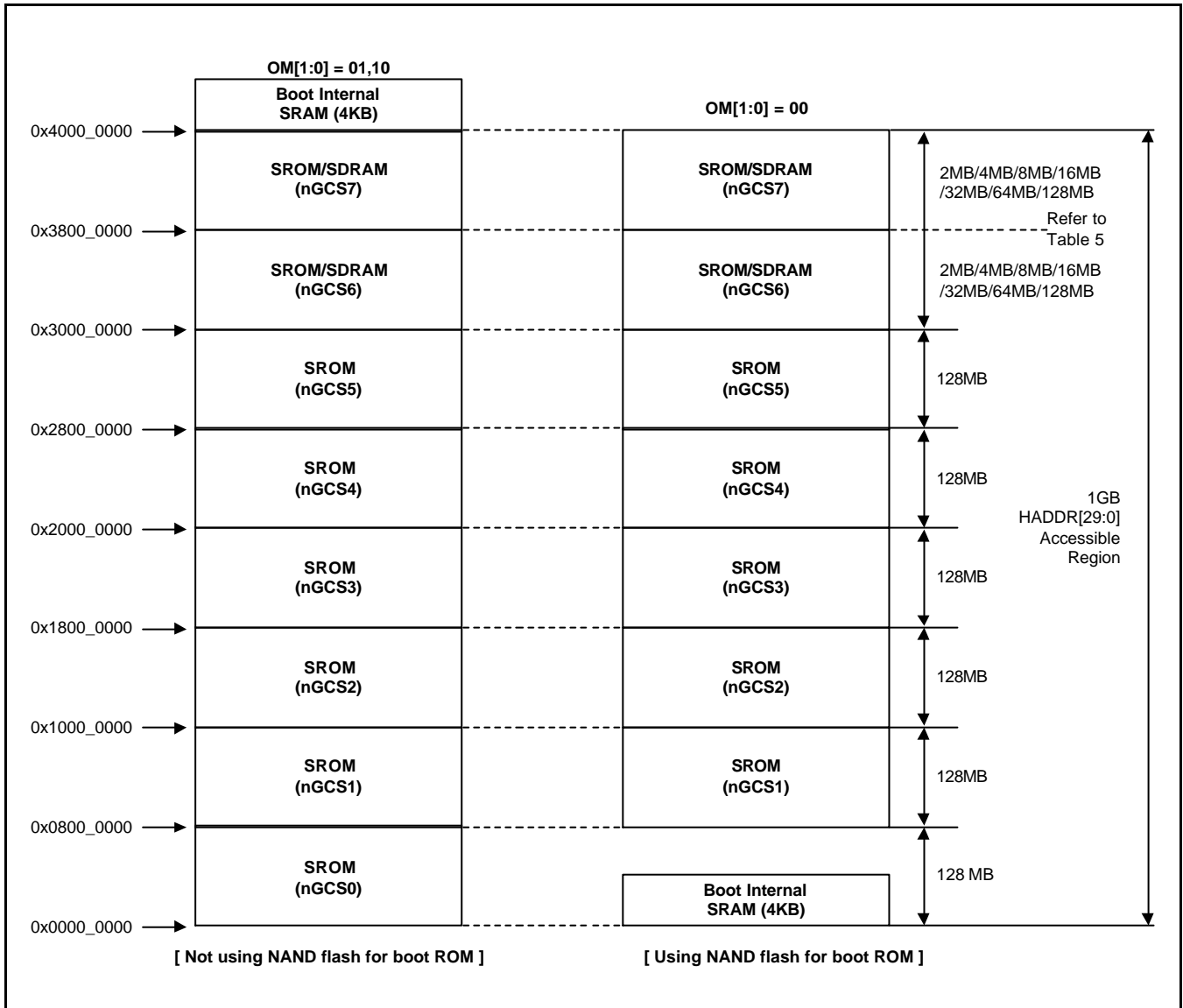

Figure 5-1. S3C2440A Memory Map after Reset

NOTE

SROM means ROM or SRAM type memory

Table 5-1. Bank 6/7 Addresses

Address	2MB	4MB	8MB	16MB	32MB	64MB	128MB
Bank 6							
Start address	0x3000_0000	0x3000_0000	0x3000_0000	0x3000_0000	0x3000_0000	0x3000_0000	0x3000_0000
End address	0x301F_FFFF	0X303F_FFFF	0X307F_FFFF	0X30FF_FFFF	0X31FF_FFFF	0X33FF_FFFF	0X37FF_FFFF
Bank 7							
Start address	0x3020_0000	0x3040_0000	0x3080_0000	0x3100_0000	0x3200_0000	0x3400_0000	0x3800_0000
End address	0X303F_FFFF	0X307F_FFFF	0X30FF_FFFF	0X31FF_FFFF	0X33FF_FFFF	0X37FF_FFFF	0X3FFF_FFFF

NOTE: Bank 6 and 7 must have the same memory size.

FUNCTION DESCRIPTION

BANK0 BUS WIDTH

The data bus of BANK0 (nGCS0) should be configured with a width as one of 16-bit and 32-bit ones. Because the BANK0 works as the booting ROM bank (map to 0x0000_0000), the bus width of BANK0 should be determined before the first ROM access, which will depend on the logic level of OM[1:0] at Reset.

OM1 (Operating Mode 1)	OM0 (Operating Mode 0)	Booting ROM Data width
0	0	Nand Flash Mode
0	1	16-bit
1	0	32-bit
1	1	Test Mode

MEMORY (SRAM/SDRAM) ADDRESS PIN CONNECTIONS

MEMORY ADDR. PIN	S3C2440A ADDR. @ 8-bit DATA BUS	S3C2440A ADDR. @ 16-bit DATA BUS	S3C2440A ADDR. @ 32-bit DATA BUS
A0	A0	A1	A2
A1	A1	A2	A3
...

SDRAM BANK ADDRESS PIN CONNECTION EXAMPLE

Table 5-2. SDRAM Bank Address Configuration Example

Bank Size	Bus Width	Base Component	Memory Configuration	Bank Address	
2MByte	x8	16Mbit	(1M x 8 x 2Bank) x 1	A20	
	x16		(512K x 16 x 2B) x 1		
4MB	x16		(1M x 8 x 2B) x 2	A21	
	x16		(1M x 8 x 2B) x 2		
8MB	x16	16Mb	(2M x 4 x 2B) x 4	A22	
	x32		(1M x 8x 2B) x 4		
	x8	64Mb	(4M x 8 x 2B) x 1	A[22:21]	
	x8		(2M x 8 x 4B) x 1	A22	
	x16		(2M x 16 x 2B) x 1		
	x16		(1M x 16 x 4B) x 1	A[22:21]	
	x32		(512K x 32 x 4B) x 1		
16MB	x32	16Mb	(2M x 4 x 2B) x 8	A23	
	x8	64Mb	(8M x 4 x 2B) x 2		
	x8		(4M x 4 x 4B) x 2	A[23:22]	
	x16		(4M x 8 x 2B) x 2	A23	
	x16		(2M x 8 x 4B) x 2		
	x32		(2M x 16 x 2B) x 2	A23	
	x32	(1M x 16 x 4B) x 2			
	x8	128Mb	(4M x 8 x 4B) x 1		
	x16		(2M x 16 x 4B) x 1	A[23:22]	
32MB	x16	64Mb	(8M x 4 x 2B) x 4	A24	
	x16		(4M x 4 x 4B) x 4	A[24:23]	
	x32		(4M x 8 x 2B) x 4	A24	
	x32		(2M x 8 x 4B) x 4		
	x16	128Mb	(4M x 8 x 4B) x 2	A[24:23]	
	x32		(2M x 16 x 4B) x 2		
	x8		256Mb		(8M x 8 x 4B) x 1
	x16				(4M x 16 x 4B) x 1
64MB	x32	128Mb	(4M x 8 x 4B) x 4	A[25:24]	
	x16	256Mb	(8M x 8 x 4B) x 2		
	x32		(4M x 16 x 4B) x 2		
	x8	512Mb	(16M x 8 x 4B) x 1		
128MB	x32	256Mb	(8M x 8 x 4Bank) x 4	A[26:25]	
	x8	512Mb	(32M x 4 x 4B) x 2		
	x16		(16M x 8 x 4B) x 2		
	x32		(8M x 16 x 4B) x 2		

nWAIT PIN OPERATION

If the WAIT bit(WSn bit in BWSCON) corresponding to each memory bank is enabled, the nOE duration should be prolonged by the external nWAIT pin while the memory bank is active. nWAIT is checked from tacc-1. nOE will be de-asserted at the next clock after sampling nWAIT is high. The nWE signal have the same relation with nOE.

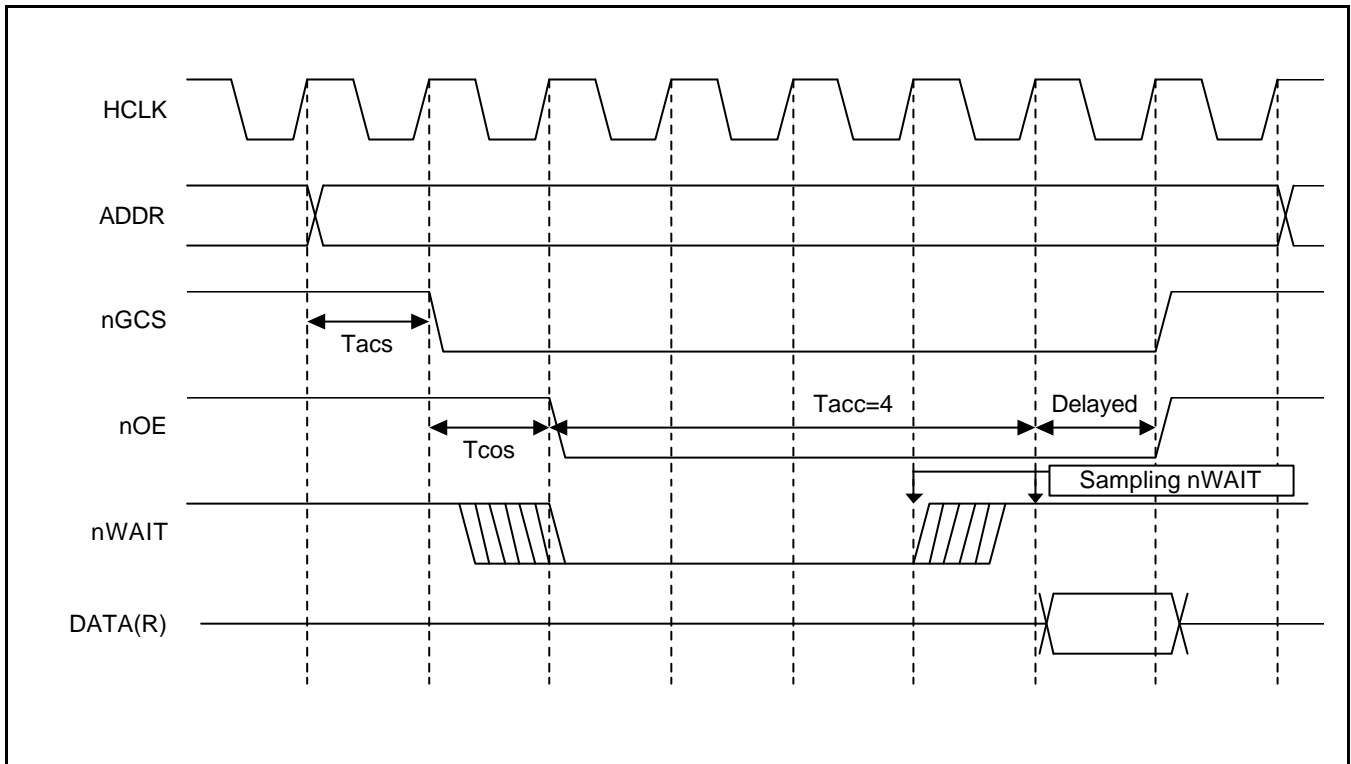

Figure 5-2. S3C2440A External nWAIT Timing Diagram (Tacc=4)

nXBREQ/nXBACK Pin Operation

If nXBREQ is asserted, the S3C2440A will respond by lowering nXBACK. If nXBACK=L, the address/data bus and memory control signals are in Hi-Z state as shown in Table 1-1. After nXBREQ is de-asserted, the nXBACK will also be de-asserted.

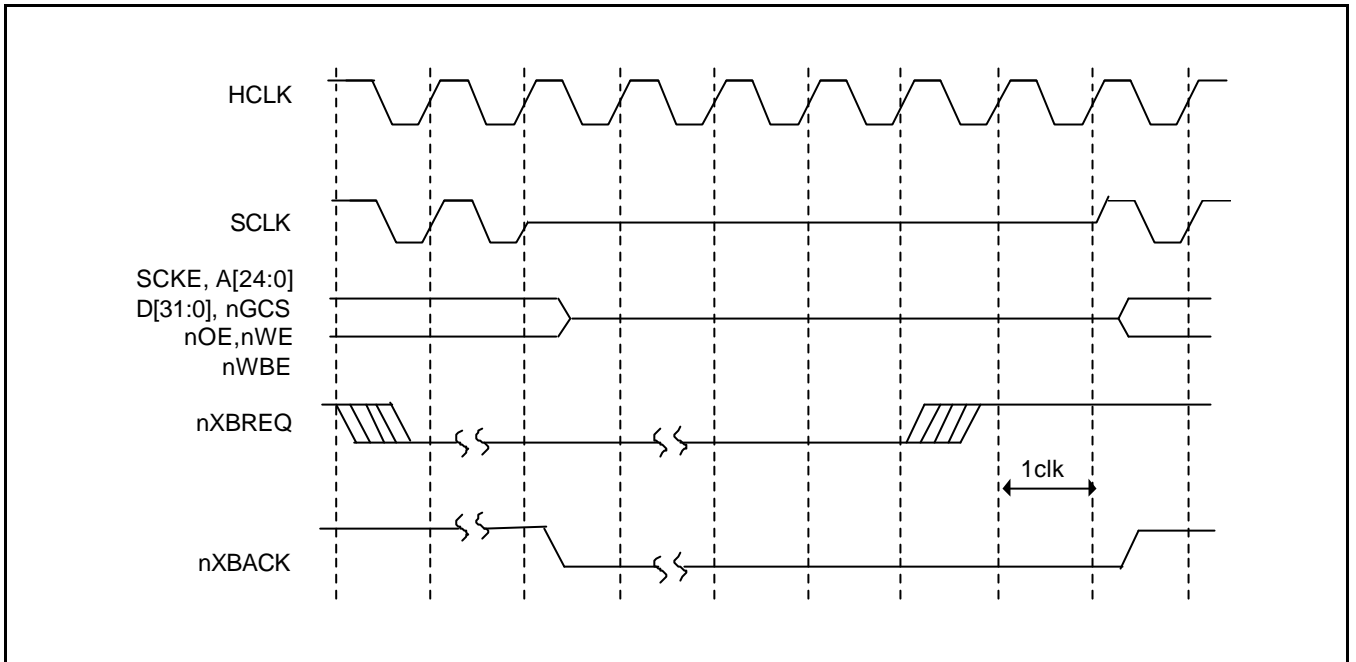

Figure 5-3. S3C2440A nXBREQ/nXBACK Timing Diagram

ROM Memory Interface Examples

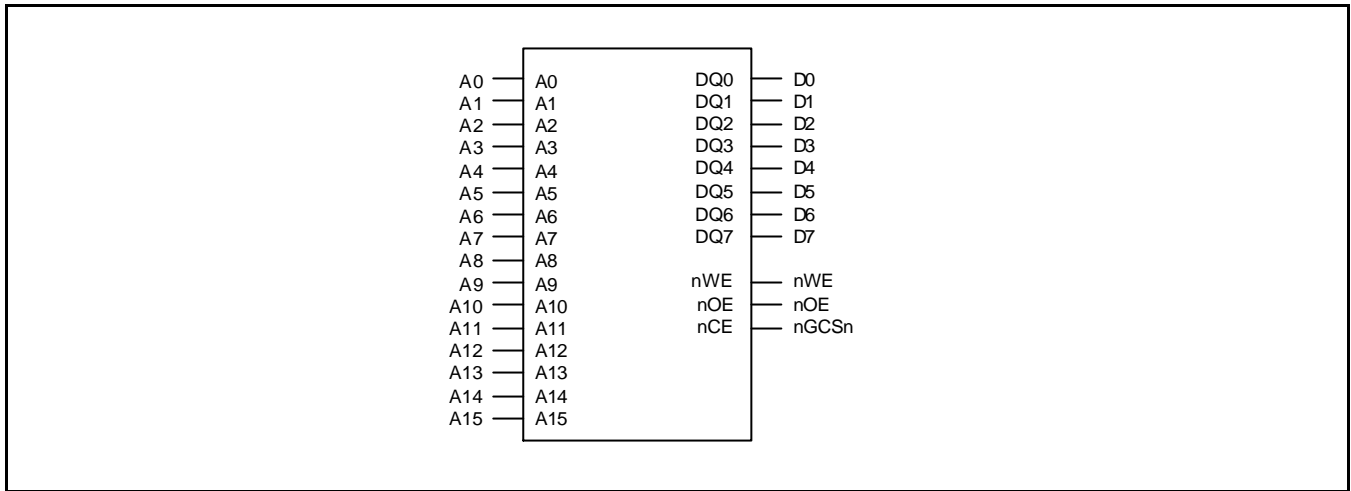

Figure 5-4. Memory Interface with 8-bit ROM

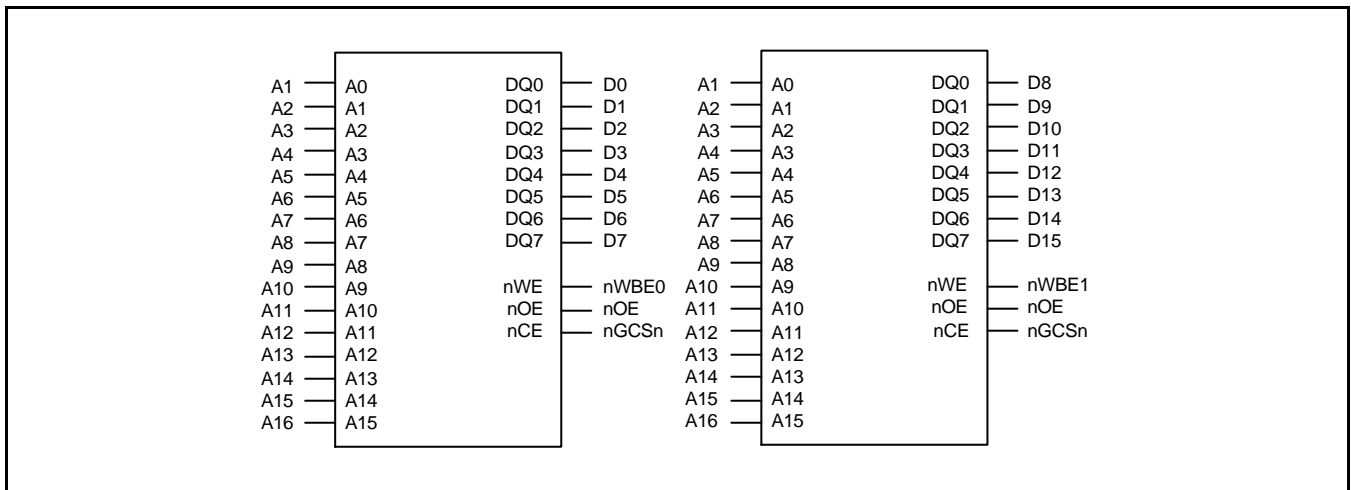

Figure 5-5. Memory Interface with 8-bit ROM x 2

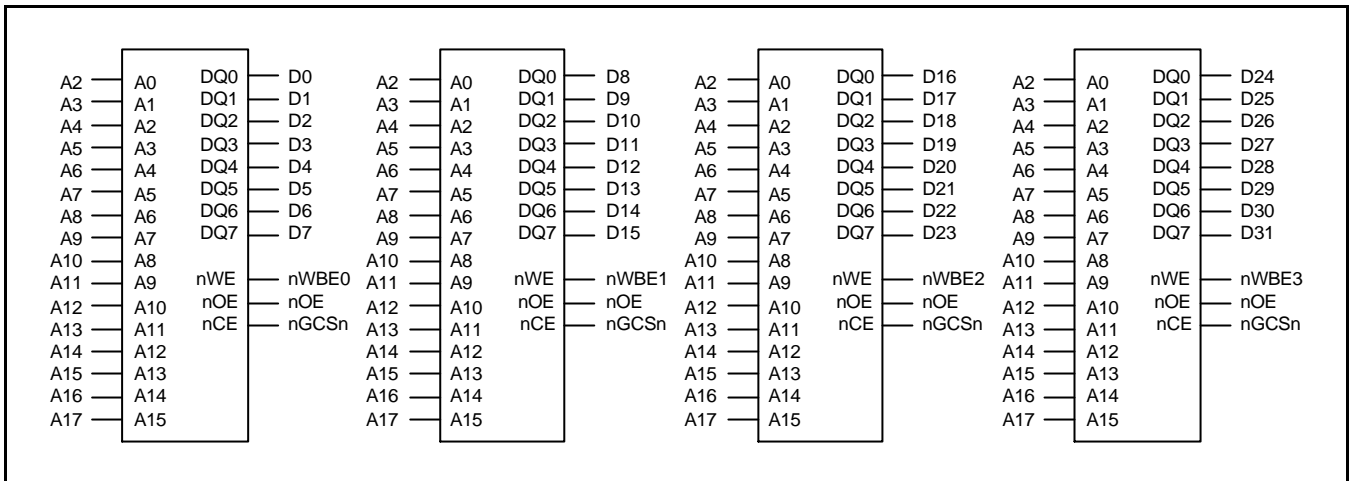

Figure 5-6. Memory Interface with 8-bit ROM x 4

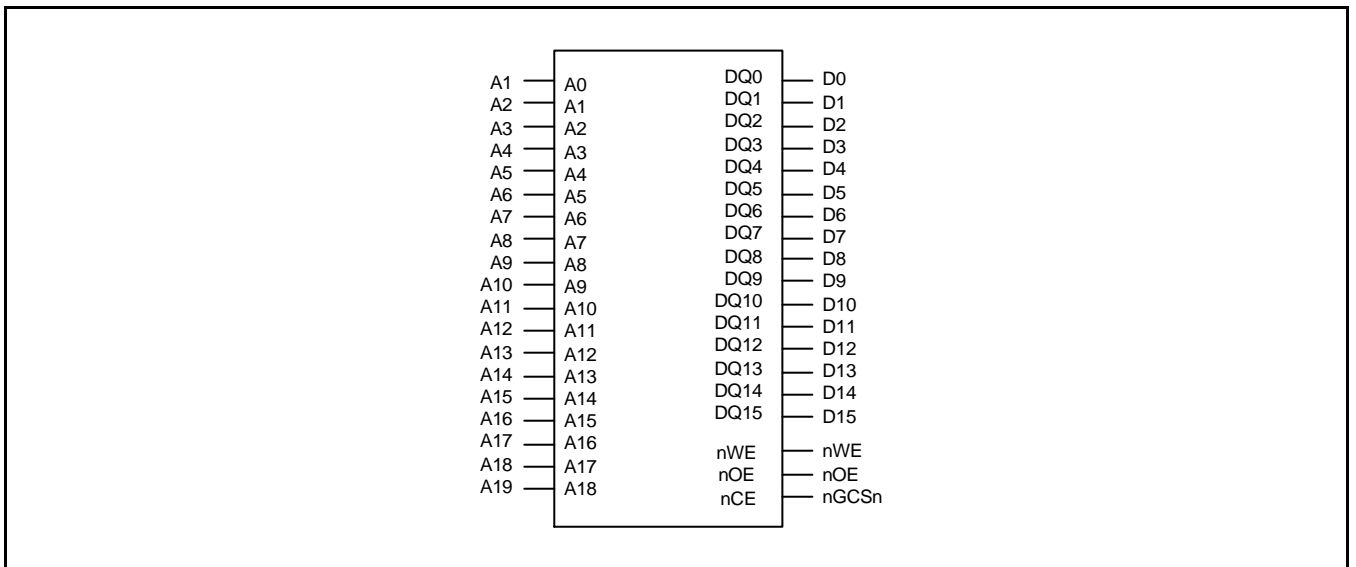

Figure 5-7. Memory Interface with 16-bit ROM

SRAM Memory Interface Examples

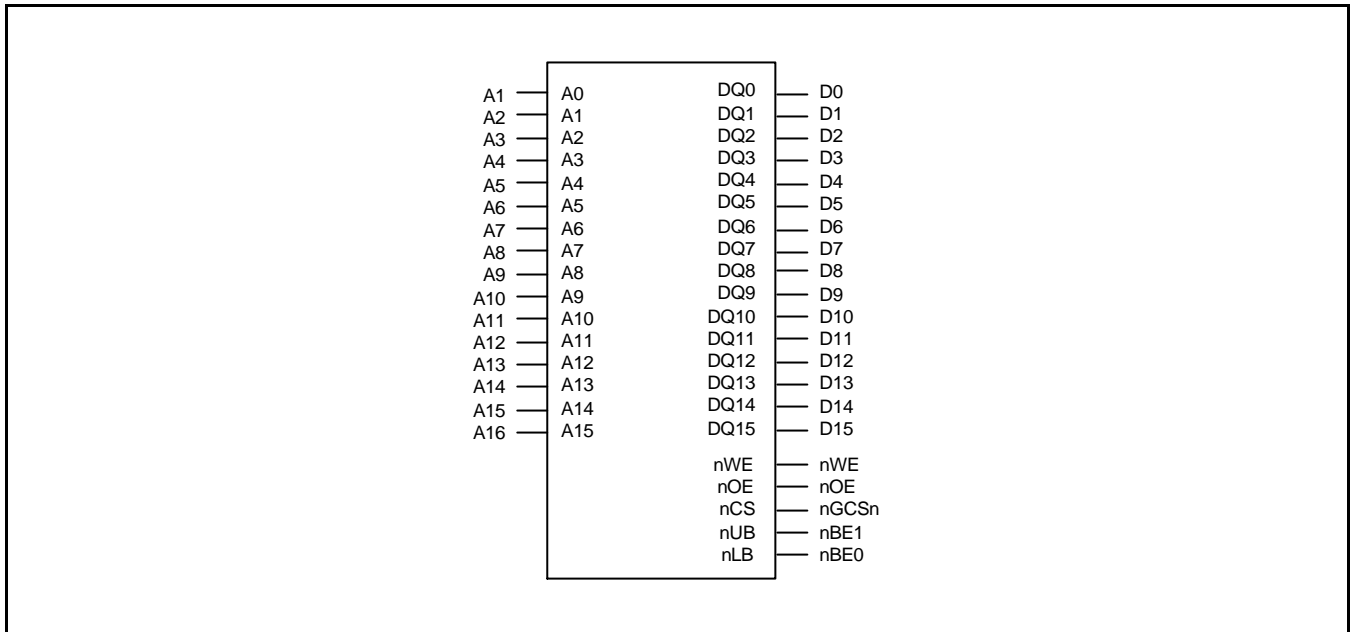

Figure 5-8. Memory Interface with 16-bit SRAM

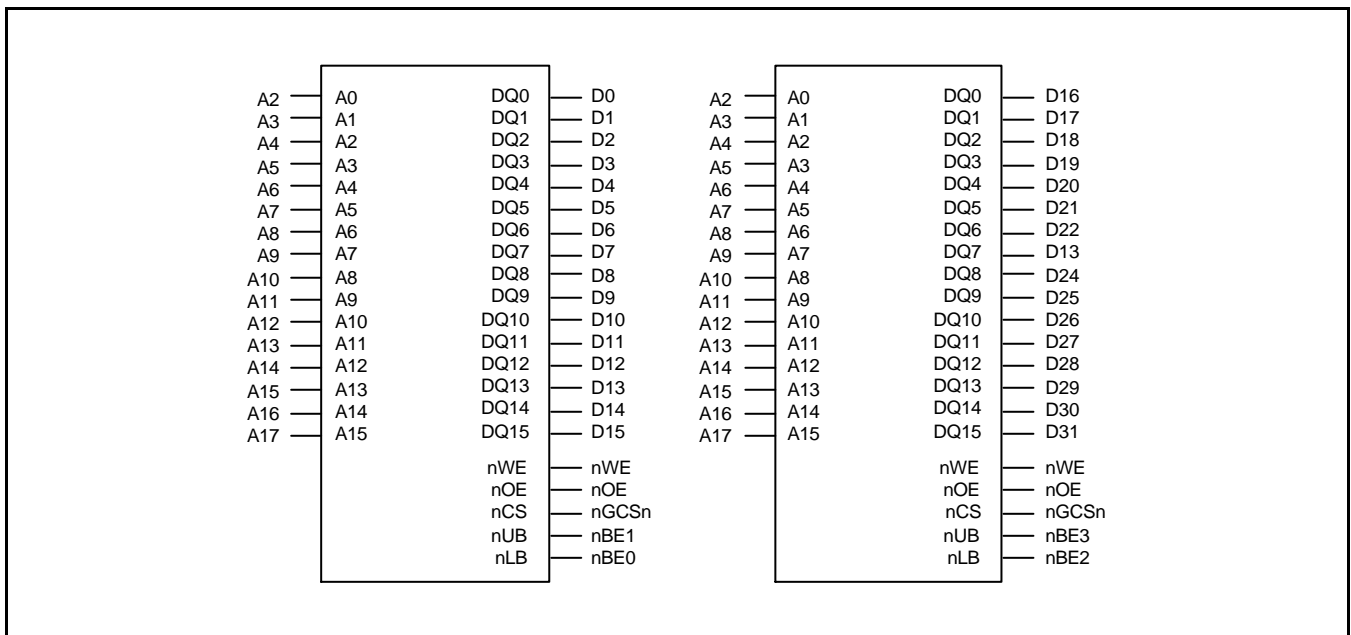

Figure 5-9. Memory Interface with 16-bit SRAM x 2

SDRAM Memory Interface Examples

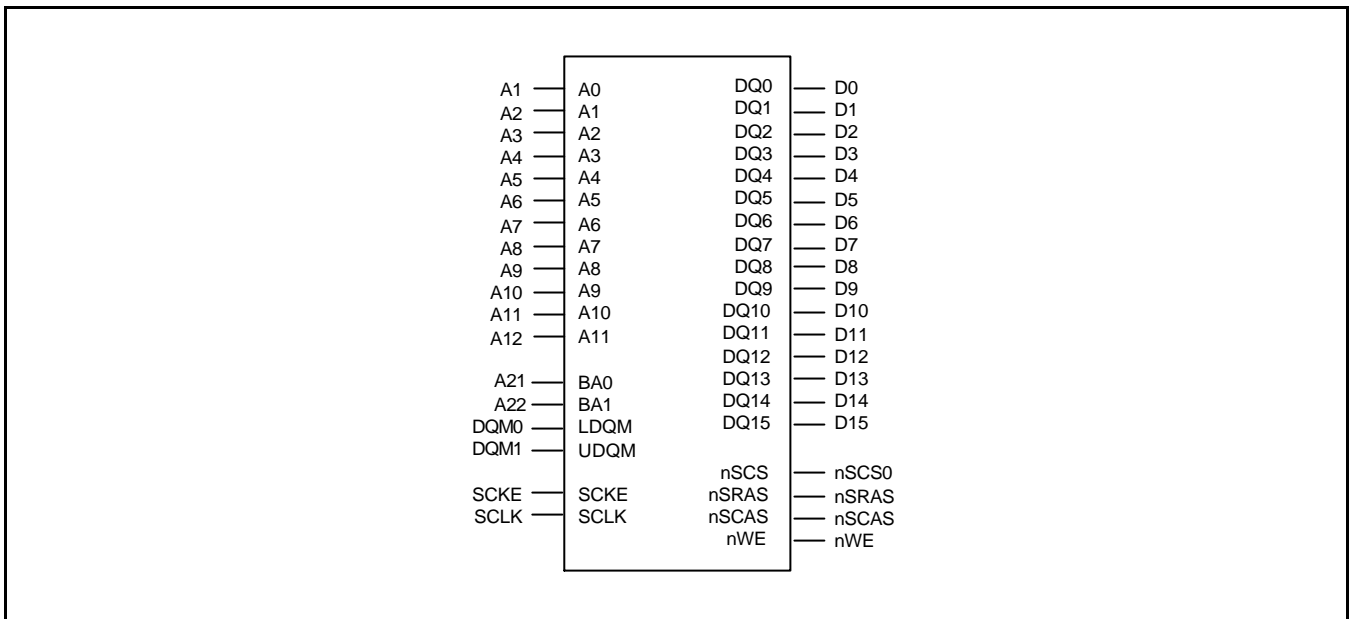

Figure 5-10. Memory Interface with 16-bit SDRAM (4Mx16, 4banks)

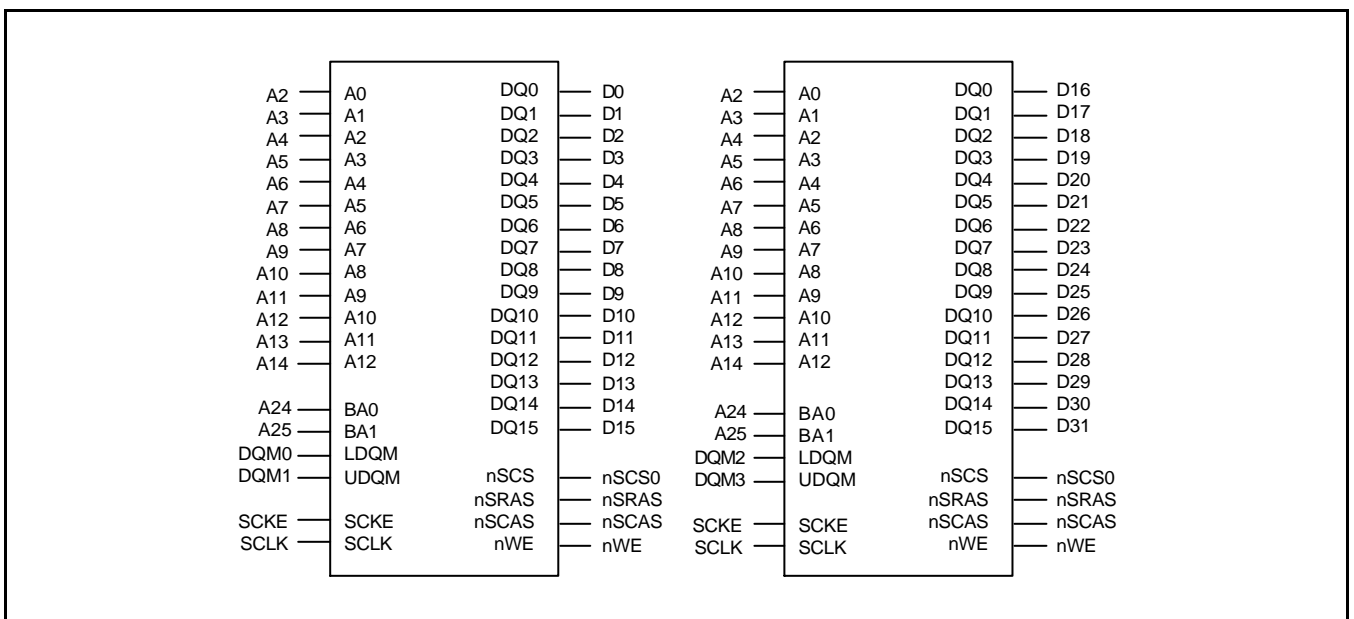

Figure 5-11. Memory Interface with 16-bit SDRAM (4Mx16x4Bank * 2ea)

NOTE

Refer to Table 5-2 for the Bank Address configurations of SDRAM.

PROGRAMMABLE ACCESS CYCLE

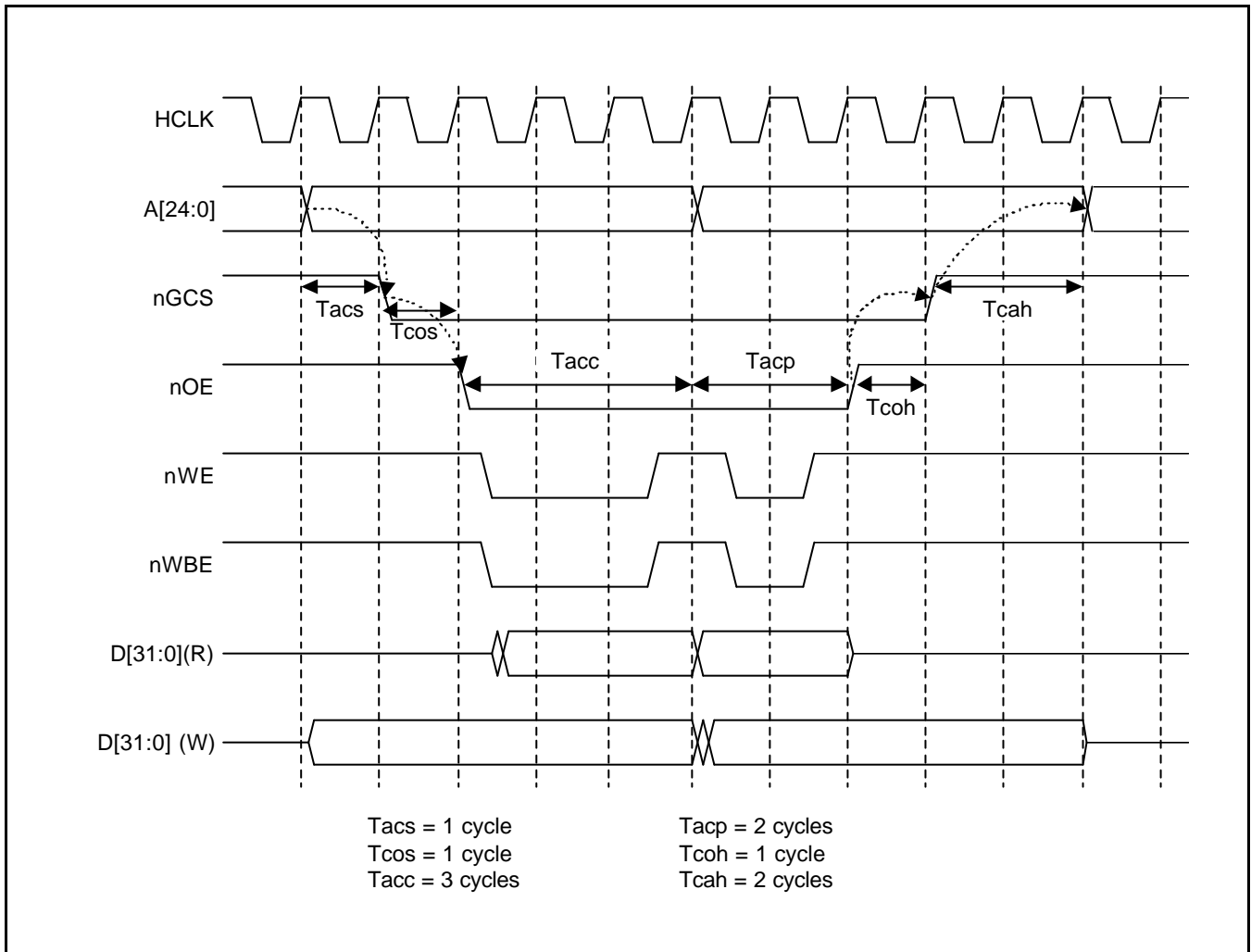

Figure 5-12. S3C2440A nGCS Timing Diagram

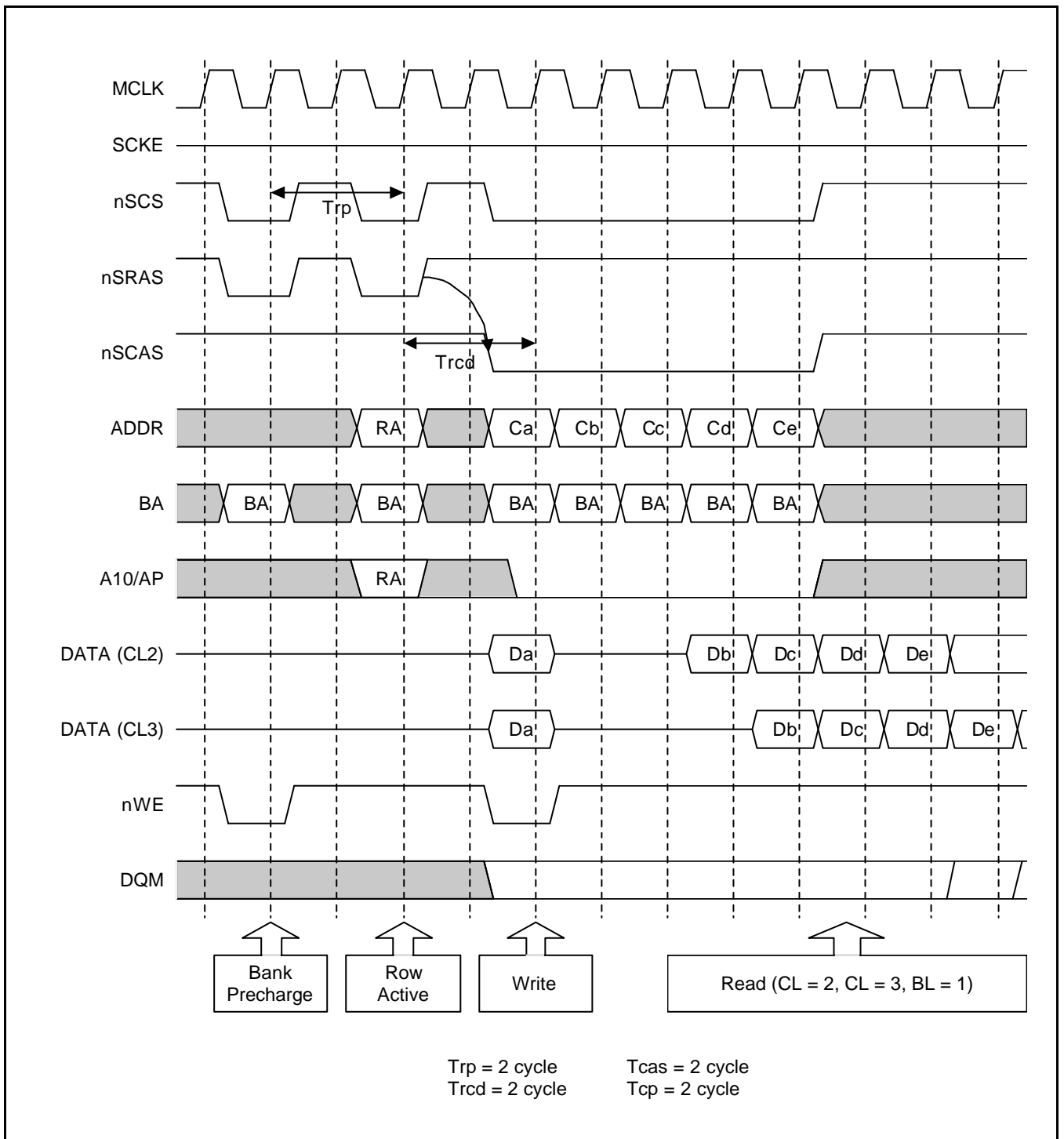

Figure 5-13. S3C2440A SDRAM Timing Diagram

BUS WIDTH & WAIT CONTROL REGISTER (BWSCON)

Register	Address	R/W	Description	Reset Value
BWSCON	0x48000000	R/W	Bus width & wait status control register	0x000000

BWSCON	Bit	Description	Initial state
ST7	[31]	Determines SRAM for using UB/LB for bank 7. 0 = Not using UB/LB (The pins are dedicated nWBE[3:0]) 1 = Using UB/LB (The pins are dedicated nBE[3:0])	0
WS7	[30]	Determines WAIT status for bank 7. 0 = WAIT disable 1 = WAIT enable	0
DW7	[29:28]	Determines data bus width for bank 7. 00 = 8-bit 01 = 16-bit, 10 = 32-bit 11 = reserved	0
ST6	[27]	Determines SRAM for using UB/LB for bank 6. 0 = Not using UB/LB (The pins are dedicated nWBE[3:0]) 1 = Using UB/LB (The pins are dedicated nBE[3:0])	0
WS6	[26]	Determines WAIT status for bank 6. 0 = WAIT disable, 1 = WAIT enable	0
DW6	[25:24]	Determines data bus width for bank 6. 00 = 8-bit 01 = 16-bit, 10 = 32-bit 11 = reserved	0
ST5	[23]	Determines SRAM for using UB/LB for bank 5. 0 = Not using UB/LB (The pins are dedicated nWBE[3:0]) 1 = Using UB/LB (The pins are dedicated nBE[3:0])	0
WS5	[22]	Determines WAIT status for bank 5. 0 = WAIT disable, 1 = WAIT enable	0
DW5	[21:20]	Determines data bus width for bank 5. 00 = 8-bit 01 = 16-bit, 10 = 32-bit 11 = reserved	0
ST4	[19]	Determines SRAM for using UB/LB for bank 4. 0 = Not using UB/LB (The pins are dedicated nWBE[3:0]) 1 = Using UB/LB (The pins are dedicated nBE[3:0])	0
WS4	[18]	Determines WAIT status for bank 4. 0 = WAIT disable 1 = WAIT enable	0
DW4	[17:16]	Determine data bus width for bank 4. 00 = 8-bit 01 = 16-bit, 10 = 32-bit 11 = reserved	0
ST3	[15]	Determines SRAM for using UB/LB for bank 3. 0 = Not using UB/LB (The pins are dedicated nWBE[3:0]) 1 = Using UB/LB (The pins are dedicated nBE[3:0])	0
WS3	[14]	Determines WAIT status for bank 3. 0 = WAIT disable 1 = WAIT enable	0
DW3	[13:12]	Determines data bus width for bank 3. 00 = 8-bit 01 = 16-bit, 10 = 32-bit 11 = reserved	0
ST2	[11]	Determines SRAM for using UB/LB for bank 2. 0 = Not using UB/LB (The pins are dedicated nWBE[3:0]) 1 = Using UB/LB (The pins are dedicated nBE[3:0].)	0

BUS WIDTH & WAIT CONTROL REGISTER (BWSCON) (Continued)

BWSCON	Bit	Description	Initial state
WS2	[10]	Determines WAIT status for bank 2. 0 = WAIT disable 1 = WAIT enable	0
DW2	[9:8]	Determines data bus width for bank 2. 00 = 8-bit 01 = 16-bit, 10 = 32-bit 11 = reserved	0
ST1	[7]	Determines SRAM for using UB/LB for bank 1. 0 = Not using UB/LB (The pins are dedicated nWBE[3:0]) 1 = Using UB/LB (The pins are dedicated nBE[3:0])	0
WS1	[6]	Determines WAIT status for bank 1. 0 = WAIT disable, 1 = WAIT enable	0
DW1	[5:4]	Determines data bus width for bank 1. 00 = 8-bit 01 = 16-bit, 10 = 32-bit 11 = reserved	0
DW0	[2:1]	Indicate data bus width for bank 0 (read only). 01 = 16-bit, 10 = 32-bit The states are selected by OM[1:0] pins	–
Reserved	[0]	Reserve to 0	0

NOTES:

- All types of master clock in this memory controller correspond to the bus clock.
For example, HCLK in SRAM is the same as the bus clock, and SCLK in SDRAM is also the same as the bus clock.
In this chapter (Memory Controller), one clock means one bus clock.
- nBE[3:0] is the 'AND' signal nWBE[3:0] and nOE.

BANK CONTROL REGISTER (BANKCONN: NGCS0-NGCS5)

Register	Address	R/W	Description	Reset Value
BANKCON0	0x48000004	R/W	Bank 0 control register	0x0700
BANKCON1	0x48000008	R/W	Bank 1 control register	0x0700
BANKCON2	0x4800000C	R/W	Bank 2 control register	0x0700
BANKCON3	0x48000010	R/W	Bank 3 control register	0x0700
BANKCON4	0x48000014	R/W	Bank 4 control register	0x0700
BANKCON5	0x48000018	R/W	Bank 5 control register	0x0700

BANKCONn	Bit	Description	Initial State
Tacs	[14:13]	Address set-up time before nGCSn 00 = 0 clock 01 = 1 clock 10 = 2 clocks 11 = 4 clocks	00
Tcos	[12:11]	Chip selection set-up time before nOE 00 = 0 clock 01 = 1 clock 10 = 2 clocks 11 = 4 clocks	00
Tacc	[10:8]	Access cycle 000 = 1 clock 001 = 2 clocks 010 = 3 clocks 011 = 4 clocks 100 = 6 clocks 101 = 8 clocks 110 = 10 clocks 111 = 14 clocks Note: When nWAIT signal is used, Tacc ≥ 4 clocks.	111
Tcoh	[7:6]	Chip selection hold time after nOE 00 = 0 clock 01 = 1 clock 10 = 2 clocks 11 = 4 clocks	000
Tcah	[5:4]	Address hold time after nGCSn 00 = 0 clock 01 = 1 clock 10 = 2 clocks 11 = 4 clocks	00
Tacp	[3:2]	Page mode access cycle @ Page mode 00 = 2 clocks 01 = 3 clocks 10 = 4 clocks 11 = 6 clocks	00
PMC	[1:0]	Page mode configuration 00 = normal (1 data) 01 = 4 data 10 = 8 data 11 = 16 data	00

BANK CONTROL REGISTER (BANKCONn: nGCS6-nGCS7)

Register	Address	R/W	Description	Reset Value
BANKCON6	0x4800001C	R/W	Bank 6 control register	0x18008
BANKCON7	0x48000020	R/W	Bank 7 control register	0x18008

BANKCONn	Bit	Description	Initial State
MT	[16:15]	Determine the memory type for bank6 and bank7. 00 = ROM or SRAM 01 = Reserved (Do not use) 10 = Reserved (Do not use) 11 = Sync. DRAM	11
Memory Type = ROM or SRAM [MT=00] (15-bit)			
Tacs	[14:13]	Address set-up time before nGCS 00 = 0 clock 01 = 1 clock 10 = 2 clocks 11 = 4 clocks	00
Tcos	[12:11]	Chip selection set-up time before nOE 00 = 0 clock 01 = 1 clock 10 = 2 clocks 11 = 4 clocks	00
Tacc	[10:8]	Access cycle 000 = 1 clock 001 = 2 clocks 010 = 3 clocks 011 = 4 clocks 100 = 6 clocks 101 = 8 clocks 110 = 10 clocks 111 = 14 clocks	111
Tcoh	[7:6]	Chip selection hold time after nOE 00 = 0 clock 01 = 1 clock 10 = 2 clocks 11 = 4 clocks	00
Tcah	[5:4]	Address hold time after nGCSn 00 = 0 clock 01 = 1clock 10 = 2 clocks 11 = 4 clocks	00
Tacp	[3:2]	Page mode access cycle @ Page mode 00 = 2 clocks 01 = 3 clocks 10 = 4 clocks 11 = 6 clocks	00
PMC	[1:0]	Page mode configuration 00 = normal (1 data) 01 = 4 consecutive accesses 10 = 8 consecutive accesses 11 = 16 consecutive accesses	00
Memory Type = SDRAM [MT=11] (4-bit)			
Trcd	[3:2]	RAS to CAS delay 00 = 2 clocks 01 = 3 clocks 10 = 4 clocks	10
SCAN	[1:0]	Column address number 00 = 8-bit 01 = 9-bit 10 = 10-bit	00

REFRESH CONTROL REGISTER

Register	Address	R/W	Description	Reset Value
REFRESH	0x48000024	R/W	SDRAM refresh control register	0xac0000

REFRESH	Bit	Description	Initial State
REFEN	[23]	SDRAM Refresh Enable 0 = Disable 1 = Enable (self or CBR/auto refresh)	1
TREFMD	[22]	SDRAM Refresh Mode 0 = CBR/Auto Refresh 1 = Self Refresh In self-refresh time, the SDRAM control signals are driven to the appropriate level.	0
Trp	[21:20]	SDRAM RAS pre-charge Time 00 = 2 clocks 01 = 3 clocks 10 = 4 clocks 11 = Not support	10
Tsrc	[19:18]	SDRAM Semi Row cycle time 00 = 4 clocks 01 = 5 clocks 10 = 6 clocks 11 = 7 clocks SDRAM Row cycle time: Trc=Tsrc+Trp If Trp = 3clocks & Tsrc = 7clocks, Trc = 3+7=10clocks.	11
Reserved	[17:16]	Not used	00
Reserved	[15:11]	Not used	0000
Refresh Counter	[10:0]	SDRAM refresh count value. Refer to chapter 6 SDRAM refresh controller bus priority section. Refresh period = $(2^{11}-\text{refresh_count}+1)/\text{HCLK}$ Ex) If refresh period is 7.8 us and HCLK is 100MHz, the refresh count is as follows: Refresh count = $2^{11} + 1 - 100 \times 7.8 = 1269$	0

BANKSIZE REGISTER

Register	Address	R/W	Description	Reset Value
BANKSIZE	0x48000028	R/W	Flexible bank size register	0x0

BANKSIZE	Bit	Description	Initial State
BURST_EN	[7]	ARM core burst operation enable. 0 = Disable burst operation. 1 = Enable burst operation.	0
Reserved	[6]	Not used	0
SCKE_EN	[5]	SDRAM power down mode enable control by SCKE 0 = SDRAM power down mode disable 1 = SDRAM power down mode enable	0
SCLK_EN	[4]	SCLK is enabled only during SDRAM access cycle for reducing power consumption. When SDRAM is not accessed, SCLK becomes 'L' level. 0 = SCLK is always active. 1 = SCLK is active only during the access (recommended).	0
Reserved	[3]	Not used	0
BK76MAP	[2:0]	BANK6/7 memory map 010 = 128MB/128MB 001 = 64MB/64MB 000 = 32M/32M 111 = 16M/16M 110 = 8M/8M 101 = 4M/4M 100 = 2M/2M	010

SDRAM MODE REGISTER SET REGISTER (MRSR)

Register	Address	R/W	Description	Reset Value
MRSRB6	0x4800002C	R/W	Mode register set register bank6	xxx
MRSRB7	0x48000030	R/W	Mode register set register bank7	xxx

MRSR	Bit	Description	Initial State
Reserved	[11:10]	Not used	–
WBL	[9]	Write burst length 0: Burst (Fixed) 1: Reserved	x
TM	[8:7]	Test mode 00: Mode register set (Fixed) 01, 10 and 11: Reserved	xx
CL	[6:4]	CAS latency 000 = 1 clock, 010 = 2 clocks, 011=3 clocks Others: reserved	xxx
BT	[3]	Burst type 0: Sequential (Fixed) 1: Reserved	x
BL	[2:0]	Burst length 000: 1 (Fixed) Others: Reserved	xxx

NOTE: MRSR register must not be reconfigured while the code is running on SDRAM.

IMPORTANT NOTE: In sleep mode, sdram has to enter sdram self-refresh mode.

6

NAND FLASH CONTORLLER

OVERVIEW

In recent times, NOR flash memory gets high in price while an SDRAM and a NAND flash memory is comparatively economical , motivating some users to execute the boot code on a NAND flash and execute the main code on an SDRAM.

S3C2440A boot code can be executed on an external NAND flash memory. In order to support NAND flash boot loader, the S3C2440A is equipped with an internal SRAM buffer called 'Steppingstone'. When booting, the first 4 KBytes of the NAND flash memory will be loaded into Steppingstone and the boot code loaded into Steppingstone will be executed.

Generally, the boot code will copy NAND flash content to SDRAM. Using hardware ECC, the NAND flash data validity will be checked. Upon the completion of the copy, the main program will be executed on the SDRAM.

FEATURES

1. **Auto boot:** The boot code is transferred into 4-kbytes Steppingstone during reset. After the transfer, the boot code will be executed on the Steppingstone.
2. **NAND Flash memory I/F:** Support 256Words, 512Bytes, 1KWords and 2KBytes Page.
3. **Software mode:** User can directly access NAND flash memory, *for example this feature can be used in read/erase/program NAND flash memory.*
4. **Interface:** 8 / 16-bit NAND flash memory interface bus.
5. **Hardware ECC generation,** detection and indication (Software correction).
6. **SFR I/F:** Support Little Endian Mode, Byte/half word/word access to Data and ECC Data register, and Word access to other registers
7. **SteppingStone I/F:** Support Little/Big Endian, Byte/half word/word access.
8. **The Steppingstone** 4-KB internal SRAM buffer can be used for another purpose after NAND flash booting.

BLOCK DIAGRAM

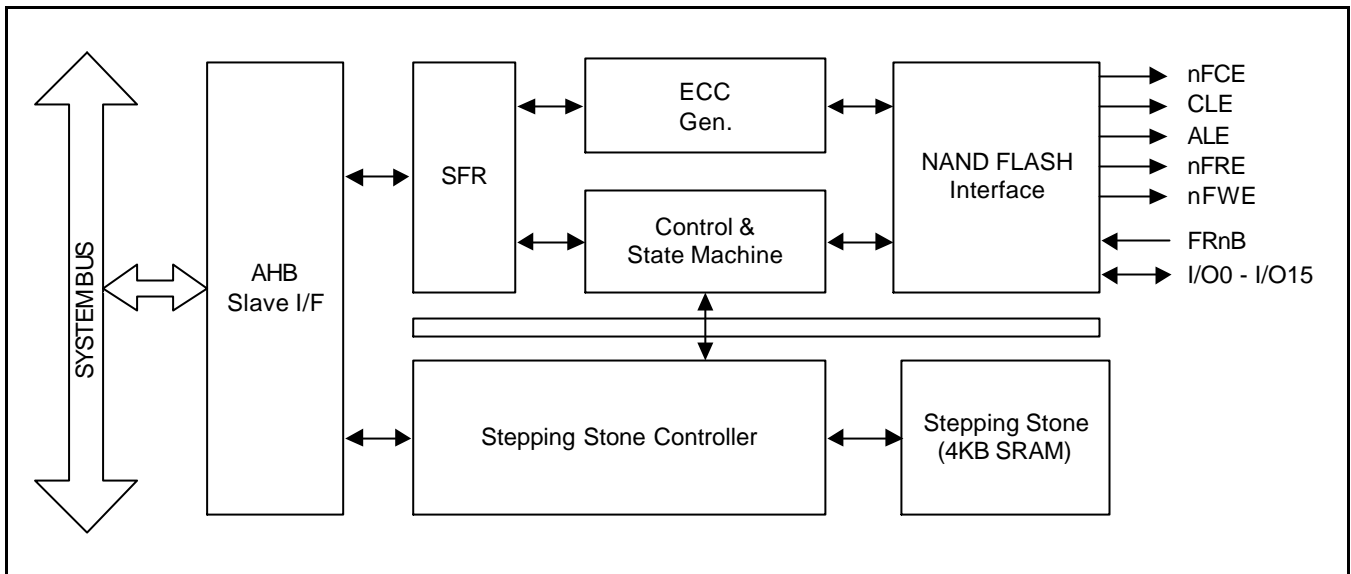

Figure 6-1. NAND Flash Controller Block Diagram

BOOT LOADER FUNCTION

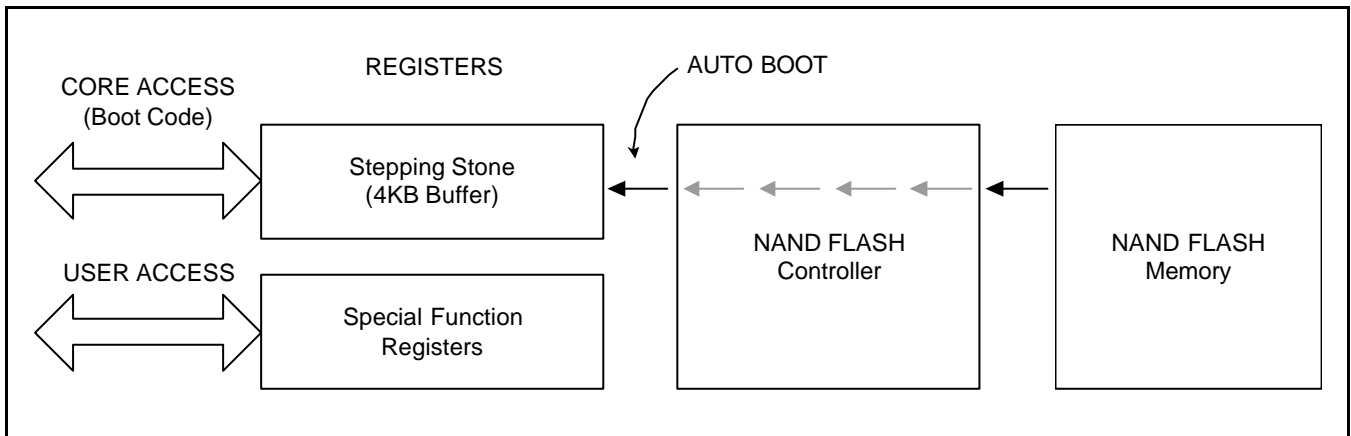

Figure 6-2. NAND Flash Controller Boot Loader Block Diagram

During reset, Nand flash controller will get information about the connected NAND flash through Pin status (NCON(Adv flash), GPG13(Page size), GPG14(Address cycle), GPG15(Bus width) – refer to **PIN CONFIGURATION**), After power-on or system reset is occurred, the NAND Flash controller load automatically the 4-KBytes boot loader codes. After loading the boot loader codes, the boot loader code in steppingstone is executed.

NOTE

During the auto boot, the ECC is not checked. So, the first 4-KB of NAND flash should have no bit error.

PIN CONFIGURATION

OM[1:0] = 00: Enable NAND flash memory boot

NCON: NAND flash memory selection(Normal / Advance)

0: Normal NAND flash(256Words/512Bytes page size, 3/4 address cycle)

1: Advance NAND flash(1KWords/2KBytes page size, 4/5 address cycle)

GPG13: NAND flash memory page capacitance selection

0: Page=256Words(NCON = 0) or Page=1KWords(NCON = 1)

1: Page=512Bytes(NCON = 0) or Page=2KBytes(NCON = 1)

GPG14: NAND flash memory address cycle selection

0: 3 address cycle(NCON = 0) or 4 address cycle(NCON = 1)

1: 4 address cycle(NCON = 0) or 5 address cycle(NCON = 1)

GPG15: NAND flash memory bus width selection

0: 8-bit bus width

1: 16-bit bus width

NOTE

The configuration pin – NCON, GPG[15:13] – will be fetched during reset.

In normal status, these pins must be set as input so that the pin status is not to be changed, when enters Sleep mode by software or unexpected cause.

NAND FLASH MEMORY CONFIGURATION TABLE

NCON0	GPG13	GPG14	GPG15
0: Normal NAND	0: 256Words	0: 3-Addr	0: 8-bit bus width
	1: 512Bytes	1: 4-Addr	
1: Advance NAND	0: 1Kwords	0: 4-Addr	1: 16-bit bus width
	1: 2Kbytes	1: 5-Addr	

NOTE: With above 4-bit, Possible total combinations are 16, but not all the value can be used.

Example) Nand flash configuration setting.

Parts	Page size/Total size	NCON0	GPG13	GPG14]	GPG15
K9S1208V0M-xxxx	512Byte / 512Mbit	0	1	1	0
K9K2G16U0M-xxxx	1KW / 2Gbit	1	0	1	1

NAND FLASH MEMORY TIMING

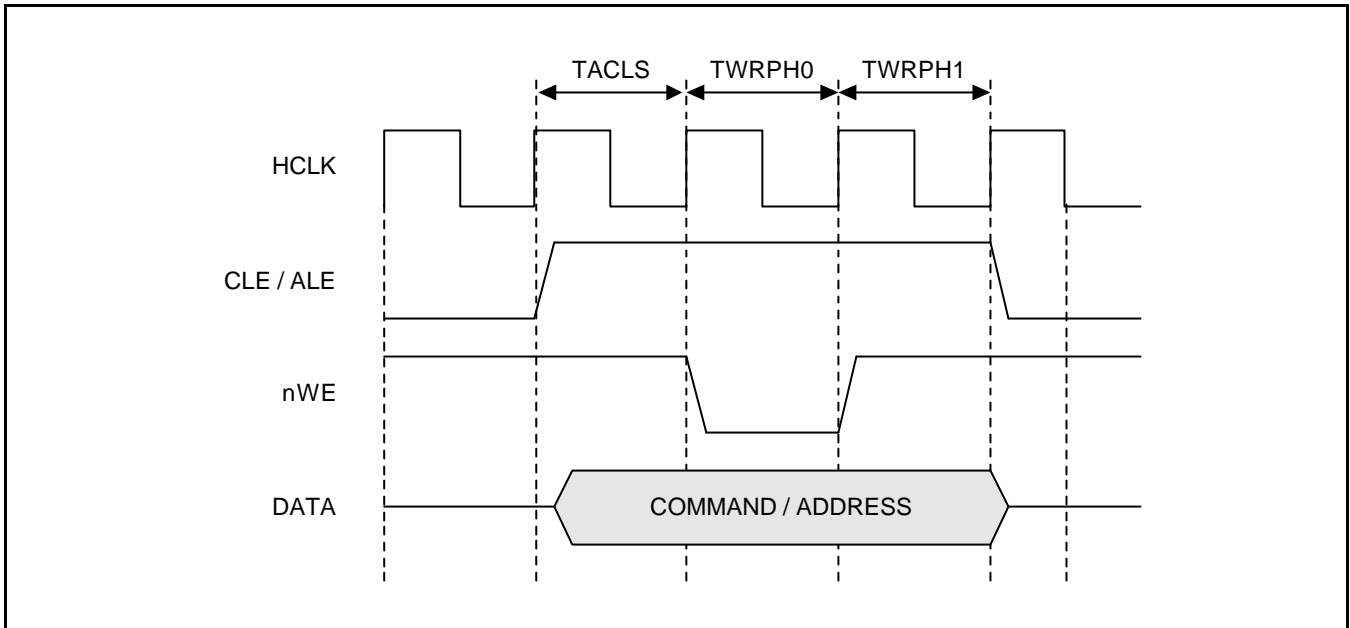

Figure 6-3. CLE & ALE Timing (TACLS=1, TWRPH0=0, TWRPH1=0)

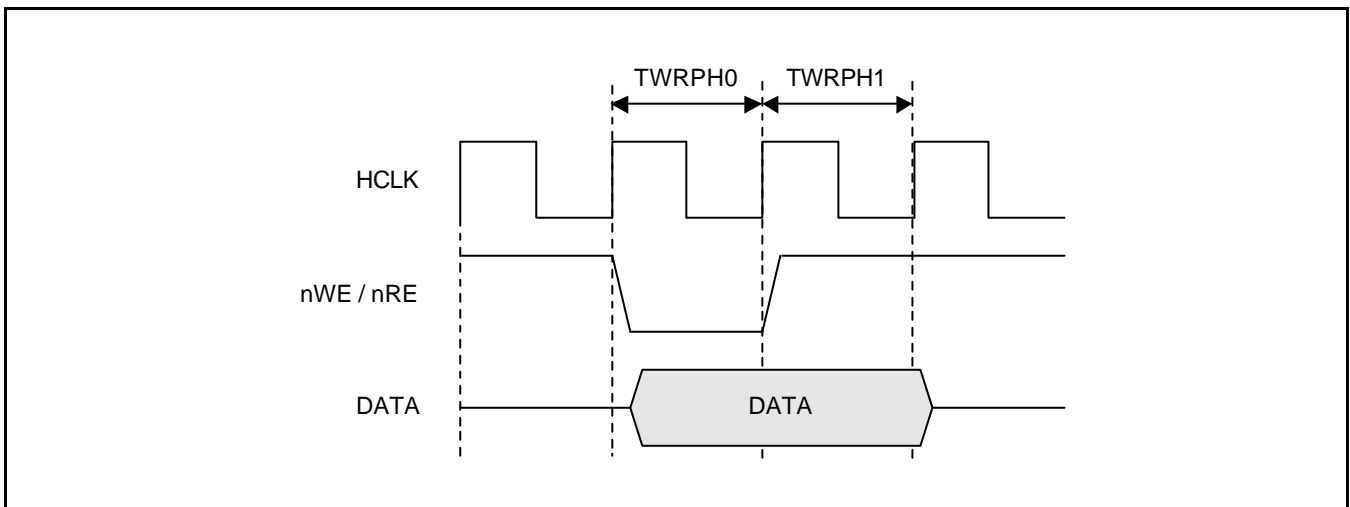

Figure 6-4. nWE & nRE Timing (TWRPH0=0, TWRPH1=0)

SOFTWARE MODE

S3C2440A supports only software mode access. Using this mode, you can completely access the NAND flash memory. The NAND Flash Controller supports direct access interface with the NAND flash memory.

1. Writing to the command register = the NAND Flash Memory command cycle
2. Writing to the address register = the NAND Flash Memory address cycle
3. Writing to the data register = write data to the NAND Flash Memory (write cycle)
4. Reading from the data register = read data from the NAND Flash Memory (read cycle)
5. Reading main ECC registers and Spare ECC registers = read data from the NAND Flash Memory

NOTE

In the software mode, you have to check the RnB status input pin by using polling or interrupt.

Data Register Configuration**1. 16-bit NAND Flash Memory Interface**

A. Word Access

Register	Endian	Bit [31:24]	Bit [23:16]	Bit [15:8]	Bit [7:0]
NFDATA	Little	2 nd I/O[15:8]	2 nd I/O[7:0]	1 st I/O[15:8]	1 st I/O[7:0]
NFDATA	Big	1 st I/O[15:8]	1 st I/O[7:0]	2 nd I/O[15:8]	2 nd I/O[7:0]

A. Half-word Access

Register	Endian	Bit [31:24]	Bit [23:16]	Bit [15:8]	Bit [7:0]
NFDATA	Little/Big	Invalid value	Invalid value	1 st I/O[15:8]	1 st I/O[7:0]

1. 8-bit NAND Flash Memory Interface

A. Word Access

Register	Endian	Bit [31:24]	Bit [23:16]	Bit [15:8]	Bit [7:0]
NFDATA	Little	4 th I/O[7:0]	3 rd I/O[7:0]	2 nd I/O[7:0]	1 st I/O[7:0]
NFDATA	Big	1 st I/O[7:0]	2 nd I/O[7:0]	3 rd I/O[7:0]	4 th I/O[7:0]

A. Half-word Access

Register	Endian	Bit [31:24]	Bit [23:16]	Bit [15:8]	Bit [7:0]
NFDATA	Little	Invalid value	Invalid value	2 nd I/O[7:0]	1 st I/O[7:0]
NFDATA	Big	Invalid value	Invalid value	1 st I/O[7:0]	2 nd I/O[7:0]

A. Byte Access

Register	Endian	Bit [31:24]	Bit [23:16]	Bit [15:8]	Bit [7:0]
NFDATA	Little/Big	Invalid value	Invalid value	Invalid value	1 st I/O[7:0]

STEPPINGSTONE (4K-BYTE SRAM)

The NAND Flash controller uses Steppingstone as the buffer on booting and also you can use this area for another purpose.

ECC (ERROR CORRECTION CODE)

NAND Flash controller consists of four ECC (Error Correction Code) modules. The two ECC modules (one for data[7:0] and the other for data[15:8]) can be used for (up to) 2048 bytes ECC Parity code generation, and the others (one for data[7:0] and the other for data[15:8]) can be used for (up to) 16 bytes ECC Parity code generation.

- 28-bit ECC Parity Code = 22-bit Line parity + 6bit Column Parity
- 14-bit ECC Parity Code = 8-bit Line parity + 6bit Column Parity

2048 BYTE ECC PARITY CODE ASSIGNMENT TABLE

	DATA7	DATA6	DATA5	DATA4	DATA3	DATA2	DATA1	DATA0
MECCn_0	P64	P64'	P32	P32'	P16	P16'	P8	P8'
MECCn_1	P1024	P1024'	P512	P512'	P256	P256'	P128	P128'
MECCn_2	P4	P4'	P2	P2'	P1	P1'	P2048	P2048'
MECCn_3	P8192	P8192'	P4096	P4096'	–	–	–	–

16 BYTE ECC PARITY CODE ASSIGNMENT TABLE

	DATA7	DATA6	DATA5	DATA4	DATA3	DATA2	DATA1	DATA0
SECCn_0	P16	P16'	P8	P8'	P4	P4'	P2	P2'
SECCn_1	P1	P1'	P64	P64'	P32	P32'	–	–

ECC MODULE FEATURES

ECC generation is controlled by the ECC Lock (MainECCLock, SpareECCLock) bit of the Control register.
ECC Register Configuration (**Little / Big Endian**)

1. 16-bit NAND Flash Memory Interface

Register	Bit [31:24]	Bit [23:16]	Bit [15:8]	Bit [7:0]
NFMECCD0	2 nd ECC for I/O[15:8]	2 nd ECC for I/O[7:0]	1 st ECC for I/O[15:8]	1 st ECC for I/O[7:0]
NFMECCD1	4 th ECC for I/O[15:8]	4 th ECC for I/O[7:0]	3 rd ECC for I/O[15:8]	3 rd ECC for I/O[7:0]

Register	Bit [31:24]	Bit [23:16]	Bit [15:8]	Bit [7:0]
NFSECCD	2 nd ECC for I/O[15:8]	2 nd ECC for I/O[7:0]	1 st ECC for I/O[15:8]	1 st ECC for I/O[7:0]

1. 8-bit NAND Flash Memory Interface

Register	Bit [31:24]	Bit [23:16]	Bit [15:8]	Bit [7:0]
NFMECCD0	–	2 nd ECC for I/O[7:0]	–	1 st ECC for I/O[7:0]
NFMECCD1	–	4 th ECC for I/O[7:0]	–	3 rd ECC for I/O[7:0]

Register	Bit [31:24]	Bit [23:16]	Bit [15:8]	Bit [7:0]
NFSECCD	–	2 nd ECC for I/O[7:0]	–	1 st ECC for I/O[7:0]

ECC PROGRAMMING GUIDE

- In software mode, ECC module generates ECC parity code for all read / write data. So you have to reset ECC value by writing the InitECC(NFCONT[4]) bit as '1' and have to clear the MainECCLock(NFCONT[5]) bit to '0'(Unlock) before read or write data.
MainECCLock(NFCONT[5]) and SpareECCLock(NFCONT[6]) control whether ECC Parity code is generated or not.
- Whenever data is read or written, the ECC module generates ECC parity code on register NFMECC0/1.
- After you completely read or write one page (not include spare area data), Set the MainECCLock bit to '1'(Lock). ECC Parity code is locked and the value of the ECC status register will not be changed.
- To generate spare area ECC parity code, Clear as '0'(Unlock) SpareECCLock(NFCONT[6]) bit.
- Whenever data is read or written, the spare area ECC module generates ECC parity code on register NFSECC.
- After you completely read or write spare area, Set the SpareECCLock bit to '1'(Lock). ECC Parity code is locked and the value of the ECC status register will not be changed.
- Once completed you can use these values to record to the spare area or check the bit error.

NOTE

NFSECCD is for ECC in the spare area (Usually, the user will write the ECC value of main data area to Spare area, which value will be the same as NFMECC0/1) and which is generated from the main data area.

NAND FLASH MEMORY MAPPING

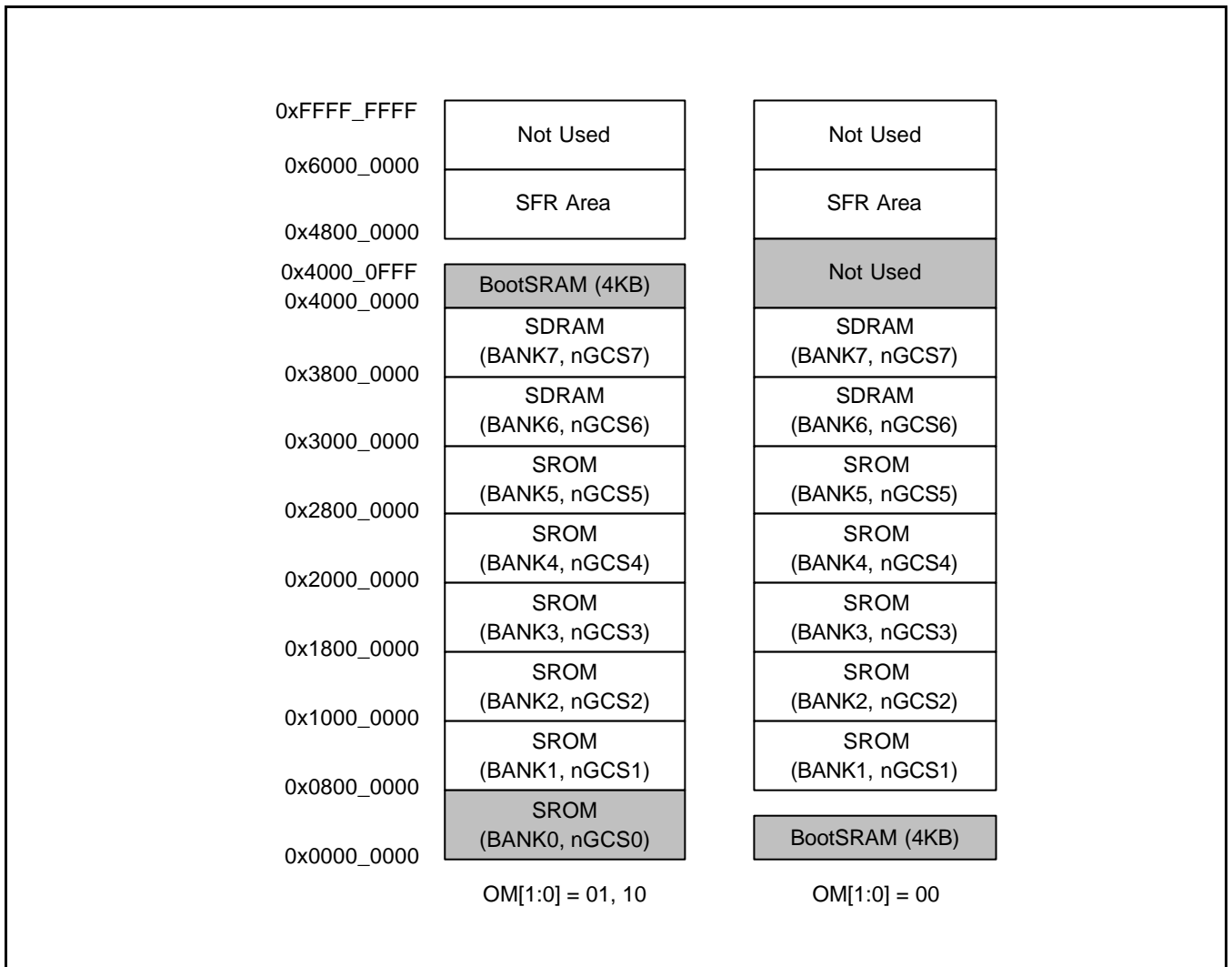

Figure 6-5. NAND Flash Memory Mapping

NOTE

SROM means ROM or SRAM type memory

NAND FLASH MEMORY CONFIGURATION

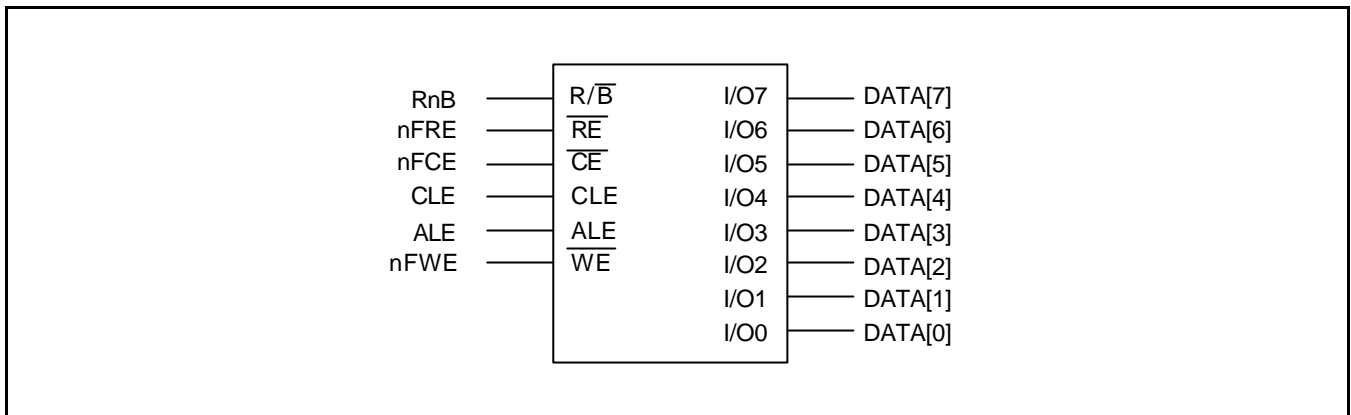

Figure 6-6. A 8-bit NAND Flash Memory Interface

When you write the address, the same address is issued from data[7:0] and data[15:8]

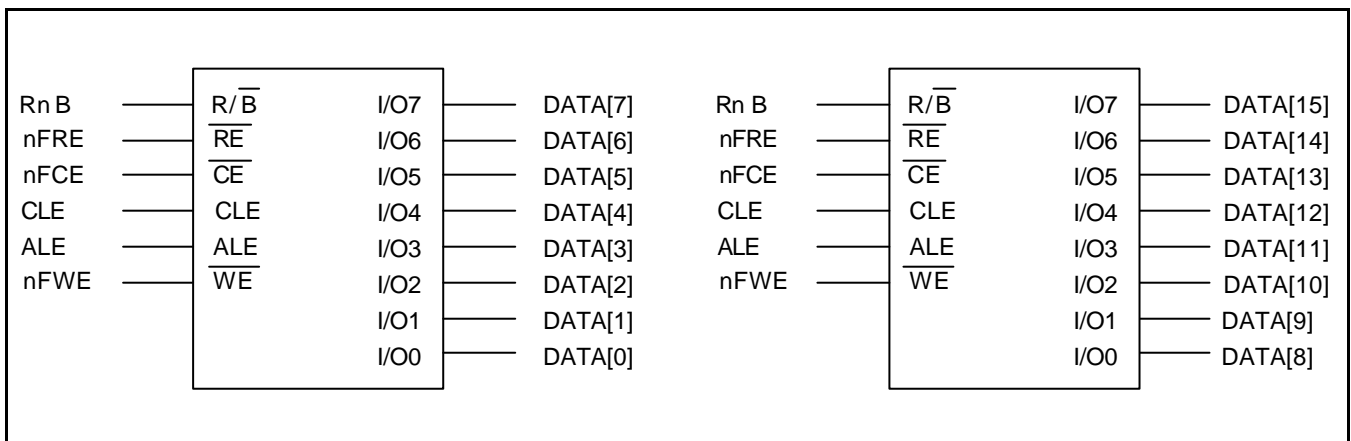

Figure 6-7. Two 8-bit NAND Flash Memory Interface

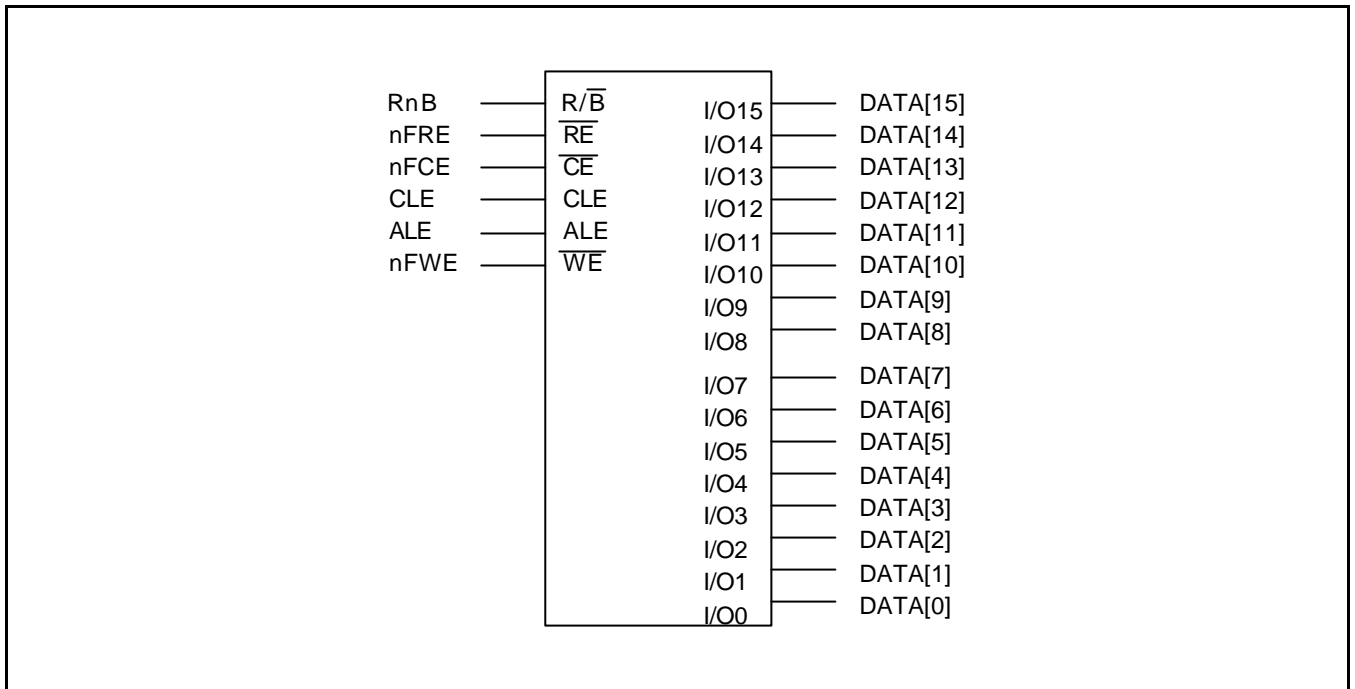

Figure 6-8. A 16-bit NAND Flash Memory Interface

NAND FLASH CONFIGURATION REGISTER

Register	Address	R/W	Description	Reset Value
NFCONF	0x4E000000	R/W	NAND flash configuration register	0x0000100X

NFCONF	Bit	Description	Initial State
Reserved	[15:14]	Reserved	–
TACLS	[13:12]	CLE & ALE duration setting value (0~3) Duration = HCLK x TACLS	01
Reserved	[11]	Reserved	0
TWRPH0	[10:8]	TWRPH0 duration setting value (0~7) Duration = HCLK x (TWRPH0 + 1)	000
Reserved	[7]	Reserved	0
TWRPH1	[6:4]	TWRPH1 duration setting value (0~7) Duration = HCLK x (TWRPH1 + 1)	000
AdvFlash (Read only)	[3]	Advance NAND flash memory for auto-booting 0: Support 256 or 512 byte/page NAND flash memory 1: Support 1024 or 2048 byte/page NAND flash memory This bit is determined by NCON0 pin status during reset and wake-up from sleep mode.	H/W Set (NCON0)
PageSize (Read only)	[2]	NAND flash memory page size for auto-booting AdvFlash PageSize When AdvFlash is 0, 0: 256 Word/page, 1: 512 Bytes/page When AdvFlash is 1, 0: 1024 Word/page, 1: 2048 Bytes/page This bit is determined by GPG13 pin status during reset and wake-up from sleep mode. After reset, the GPG13 can be used as general I/O port or External interrupt.	H/W Set (GPG13)
AddrCycle (Read only)	[1]	NAND flash memory Address cycle for auto-booting AdvFlash AddrCycle When AdvFlash is 0, 0: 3 address cycle 1: 4 address cycle When AdvFlash is 1, 0: 4 address cycle 1: 5 address cycle This bit is determined by GPG14pin status during reset and wake-up from sleep mode. After reset, the GPG14can be used as general I/O port or External interrupt.	H/W Set (GPG14)
BusWidth (R/W)	[0]	NAND Flash Memory I/O bus width for auto-booting and general access. 0: 8-bit bus 1: 16-bit bus This bit is determined by GPG15 pin status during reset and wake-up from sleep mode. After reset, the GPG15 can be used as general I/O port or External interrupt. This bit can be changed by software.	H/W Set (GPG15)

CONTROL REGISTER

Register	Address	R/W	Description	Reset Value
NFCONT	0x4E000004	R/W	NAND flash control register	0x0384

NFCONT	Bit	Description	Initial State
Reserved	[14:15]	Reserved	0
Lock-tight	[13]	Lock-tight configuration 0: Disable lock-tight 1: Enable lock-tight, Once this bit is set to 1, you cannot clear. Only reset or wake up from sleep mode can make this bit disable(can not cleared by software). When it is set to 1, the area setting in NFSBLK(0x4E000038) to NFEBLK(0x4E00003C)-1 is unlocked, and except this area, write or erase command will be invalid and only read command is valid. When you try to write or erase locked area, the illegal access will be occur (NFSTAT[3] bit will be set). If the NFSBLK and NFEBLK are same, entire area will be locked.	0
Soft Lock	[12]	Soft Lock configuration 0: Disable lock 1: Enable lock Soft lock area can be modified at any time by software. When it is set to 1, the area setting in NFSBLK(0x4E000038) to NFEBLK(0x4E00003C)-1 is unlocked, and except this area, write or erase command will be invalid and only read command is valid. When you try to write or erase locked area, the illegal access will be occur (NFSTAT[3] bit will be set). If the NFSBLK and NFEBLK are same, entire area will be locked.	1
Reserved	[11]	Reserved	0
EnbIllegalAccINT	[10]	Illegal access interrupt control 0: Disable interrupt 1: Enable interrupt Illegal access interrupt is occurred when CPU tries to program or erase locking area (the area setting in NFSBLK(0x4E000038) to NFEBLK(0x4E00003C)-1).	0
EnbRnBINT	[9]	RnB status input signal transition interrupt control 0: Disable RnB interrupt 1: Enable RnB interrupt	0
RnB_TransMode	[8]	RnB transition detection configuration 0: Detect rising edge 1: Detect falling edge	0
Reserved	[7]	Reserved	0

CONTROL REGISTER (Continued)

NFCONT	Bit	Description	Initial State
SpareECCLock	[6]	Lock spare area ECC generation. 0: Unlock spare ECC 1: Lock spare ECC Spare area ECC status register is FSECC(0x4E000034)	1
MainECCLock	[5]	Lock Main data area ECC generation 0: Unlock main data area ECC generation 1: Lock main data area ECC generation Main area ECC status register is NFMECC0/1 (0x4E00002C/30)	1
InitECC	[4]	Initialize ECC decoder/encoder(Write-only) 1: Initialize ECC decoder/encoder	0
Reserved	[2:3]	Reserved	00
Reg_nCE	[1]	NAND Flash Memory nFCE signal control 0: Force nFCE to low (Enable chip select) 1: Force nFCE to high (Disable chip select) Note: During boot time, it is controlled automatically. This value is only valid while MODE bit is 1	1
MODE	[0]	NAND flash controller operating mode 0: NAND flash controller disable (Don't work) 1: NAND flash controller enable	0

COMMAND REGISTER

Register	Address	R/W	Description	Reset Value
NFCMMD	0x4E000008	R/W	NAND flash command set register	0x00

NFCMMD	Bit	Description	Initial State
Reserved	[15:8]	Reserved	0x00
NFCMMD	[7:0]	NAND flash memory command value	0x00

ADDRESS REGISTER

Register	Address	R/W	Description	Reset Value
NFADDR	0x4E00000C	R/W	NAND flash address set register	0x0000XX00

REG_ADDR	Bit	Description	Initial State
Reserved	[15:8]	Reserved	0x00
NFADDR	[7:0]	NAND flash memory address value	0x00

DATA REGISTER

Register	Address	R/W	Description	Reset Value
NFDATA	0x4E000010	R/W	NAND flash data register	0xFFFF

NFDATA	Bit	Description	Initial State
NFDATA	[31:0]	NAND flash read/program data value for I/O Note: Refer to data register configuration in Page 6-5.	0xFFFF

MAIN DATA AREA REGISTER

Register	Address	R/W	Description	Reset Value
NFMECCD0	0x4E000014	R/W	NAND Flash ECC 1 st and 2 nd register for main data read Note: Refer to ECC module features in Page 6-8.	0x00000000
NFMECCD1	0x4E000018	R/W	NAND Flash ECC 3 rd 4 th register for main data read Note: Refer to ECC module features in Page 6-8.	0x00000000

NFMECCD0	Bit	Description	Initial State
ECCData1_1	[31:24]	2 nd ECC for I/O[15:8]	0x00
ECCData1_0	[23:16]	2 nd ECC for I/O[7:0] Note : In Software mode, Read this register when you need to read 2 nd ECC value from NAND flash memory	0x00
ECCData0_1	[15:8]	1 st ECC for I/O[15:8]	0x00
ECCData0_0	[7:0]	1 st ECC for I/O[7:0] Note: In Software mode, Read this register when you need to read 1 st ECC value from NAND flash memory. This register has same read function of NFDATA.	0x00

NOTE: Only word access is valid.

NFMECCD1	Bit	Description	Initial State
ECCData3_1	[31:24]	4 th ECC for I/O[15:8]	0x00
ECCData3_0	[23:16]	4 th ECC for I/O[7:0] Note: In Software mode, Read this register when you need to read 4 th ECC value from NAND flash memory.	0x00
ECCData2_1	[15:8]	3 rd ECC for I/O[15:8]	0x00
ECCData2_0	[7:0]	3 rd ECC for I/O[7:0] Note: In Software mode, Read this register when you need to read 3 rd ECC value from NAND flash memory. This register has same read function of NFDATA.	0x00

NOTE: Only word access is valid.

SPARE AREA ECC REGISTER

Register	Address	R/W	Description	Reset Value
NFSECCD	0x4E00001C	R/W	NAND flash ECC (Error Correction Code) register for spare area data read	0x00000000

NFSECCD	Bit	Description	Initial State
ECCData1_1	[31:24]	2 nd ECC for I/O[15:8]	0x00
ECCData1_0	[23:16]	2 nd ECC for I/O[7:0] Note: In Software mode, Read this register when you need to read 2 nd ECC value from NAND flash memory.	0x00
ECCData0_1	[15:8]	1 st ECC for I/O[15:8]	0x00
ECCData0_0	[7:0]	1 st ECC for I/O[7:0] Note: In Software mode, Read this register when you need to read 1 st ECC value from NAND flash memory. This register has same read function of NFDATA.	0x00

NOTE: Only word access is valid.

NFCON STATUS REGISTER

Register	Address	R/W	Description	Reset Value
NFSTAT	0x4E000020	R/W	NAND flash operation status register	0xXX00

NFSTAT	Bit	Description	Initial State
Reserved	[7]	Reserved	X
Reserved	[4:6]	Reserved	0
IllegalAccess	[3]	Once Soft Lock or Lock-tight is enabled, The illegal access (program, erase) to the memory makes this bit set. 0: illegal access is not detected 1: illegal access is detected	0
RnB_TransDetect	[2]	When RnB low to high transition is occurred, this value set and issue interrupt if enabled. To clear this value write '1'. 0: RnB transition is not detected 1: RnB transition is detected Transition configuration is set in RnB_TransMode (NFCONT[8]).	0
nCE (Read-only)	[1]	The status of nCE output pin	1
RnB (Read-only)	[0]	The status of RnB input pin. 0: NAND Flash memory busy 1: NAND Flash memory ready to operate	1

ECC0/1 STATUS REGISTER

Register	Address	R/W	Description	Reset Value
NFESTAT0	0x4E000024	R/W	NAND flash ECC Status register for I/O [7:0]	0x00000000
NFESTAT1	0x4E000028	R/W	NAND flash ECC status register for I/O [15:8]	0x00000000

NFESTAT0	Bit	Description	Initial State
SErrorDataNo	[24:21]	In spare area, Indicates which number data is error	00
SErrorBitNo	[20:18]	In spare area, Indicates which bit is error	000
MErrorDataNo	[17:7]	In main data area, Indicates which number data is error	0x00
MErrorBitNo	[6:4]	In main data area, Indicates which bit is error	000
SpareError	[3:2]	Indicates whether spare area bit fail error occurred 00: No Error 01: 1-bit error(correctable) 10: Multiple error 11: ECC area error	00
MainError	[1:0]	Indicates whether main data area bit fail error occurred 00: No Error 01: 1-bit error(correctable) 10: Multiple error 11: ECC area error	00

NOTE: The above values are only valid when both ECC register and ECC status register have valid value.

NFESTAT1	Bit	Description	Initial State
SErrorDataNo	[24:21]	In spare area, Indicates which number data is error	00
SErrorBitNo	[20:18]	In spare area, Indicates which bit is error	000
MErrorDataNo	[17:7]	In main data area, Indicates which number data is error	0x00
MErrorBitNo	[6:4]	In main data area, Indicates which bit is error	000
SpareError	[3:2]	Indicates whether spare area bit fail error occurred 00: No Error 01: 1-bit error(correctable) 10: Multiple error 11: ECC area error	00
MainError	[1:0]	Indicates whether main data area bit fail error occurred 00: No Error 01: 1-bit error(correctable) 10: Multiple error 11: ECC area error	00

NOTE: The above values are only valid when both ECC register and ECC status register have valid value.

MAIN DATA AREA ECC0 STATUS REGISTER

Register	Address	R/W	Description	Reset Value
NFMECC0	0x4E00002C	R	NAND flash ECC register for data[7:0]	0xFFFFFFFF
NFMECC1	0x4E000030	R	NAND flash ECC register for data[15:8]	0xFFFFFFFF

NFMECC0	Bit	Description	Initial State
MECC0_3	[31:24]	ECC3 for data[7:0]	0xFF
MECC0_2	[23:16]	ECC2 for data[7:0]	0xFF
MECC0_1	[15:8]	ECC1 for data[7:0]	0xFF
MECC0_0	[7:0]	ECC0 for data[7:0]	0xFF

NFMECC1	Bit	Description	Initial State
MECC1_3	[31:24]	ECC3 data[15:8]	0xFF
MECC1_2	[23:16]	ECC2 data[15:8]	0xFF
MECC1_1	[15:8]	ECC1 data[15:8]	0xFF
MECC1_0	[7:0]	ECC0 data[15:8]	0xFF

NOTE: The NAND flash controller generate NFMECC0/1 when read or write main area data while the MainECCLock(NFCONT[5]) bit is '0'(Unlock).

SPARE AREA ECC STATUS REGISTER

Register	Address	R/W	Description	Reset Value
NFSECC	0x4E000034	R	NAND flash ECC register for I/O [15:0]	0xFFFFFFFF

NFSECC	Bit	Description	Initial State
SECC1_1	[31:24]	Spare area ECC1 status for I/O[15:8]	0xFF
SECC1_0	[23:16]	Spare area ECC0 status for I/O[15:8]	0xFF
SECC0_1	[15:8]	Spare area ECC1 status for I/O[7:0]	0xFF
SECC0_0	[7:0]	Spare area ECC0 status for I/O[7:0]	0xFF

NOTE: The NAND flash controller generate NFSECC when read or write spare area data while the SpareECCLock(NFCONT[6]) bit is '0'(Unlock).

BLOCK ADDRESS REGISTER

Register	Address	R/W	Description	Reset Value
NFSBLK	0x4E000038	R/W	NAND flash programmable start block address	0x000000
NFEBLK	0x4E00003C	R/W	NAND flash programmable end block address Nand Flash can be programmed between start and end address. When the soft lock or lock-tight is enabled and the start and end address has same value, Entire area of NAND flash will be locked.	0x000000

NFSBLK	Bit	Description	Initial State
SBLK_ADDR2	[23:16]	The 3 rd block address of the block erase operation	0x00
SBLK_ADDR1	[15:8]	The 2 nd block address of the block erase operation	0x00
SBLK_ADDR0	[7:0]	The 1 st block address of the block erase operation (Only bit [7:5] are valid)	0x00

NOTE: Advance Flash's block Address start from 3-address cycle. So block address register only needs 3-bytes.

NFEBLK	Bit	Description	Initial State
EBLK_ADDR2	[23:16]	The 3 rd block address of the block erase operation	0x00
EBLK_ADDR1	[15:8]	The 2 nd block address of the block erase operation	0x00
EBLK_ADDR0	[7:0]	The 1 st block address of the block erase operation (Only bit [7:5] are valid)	0x00

NOTE: Advance Flash's block Address start from 3-address cycle. So block address register only needs 3-bytes.

The NFSLK and NFEBLK can be changed while Soft lock bit(NFCONT[12]) is enabled. But cannot be changed when Lock-tight bit(NFCONT[13]) is set.

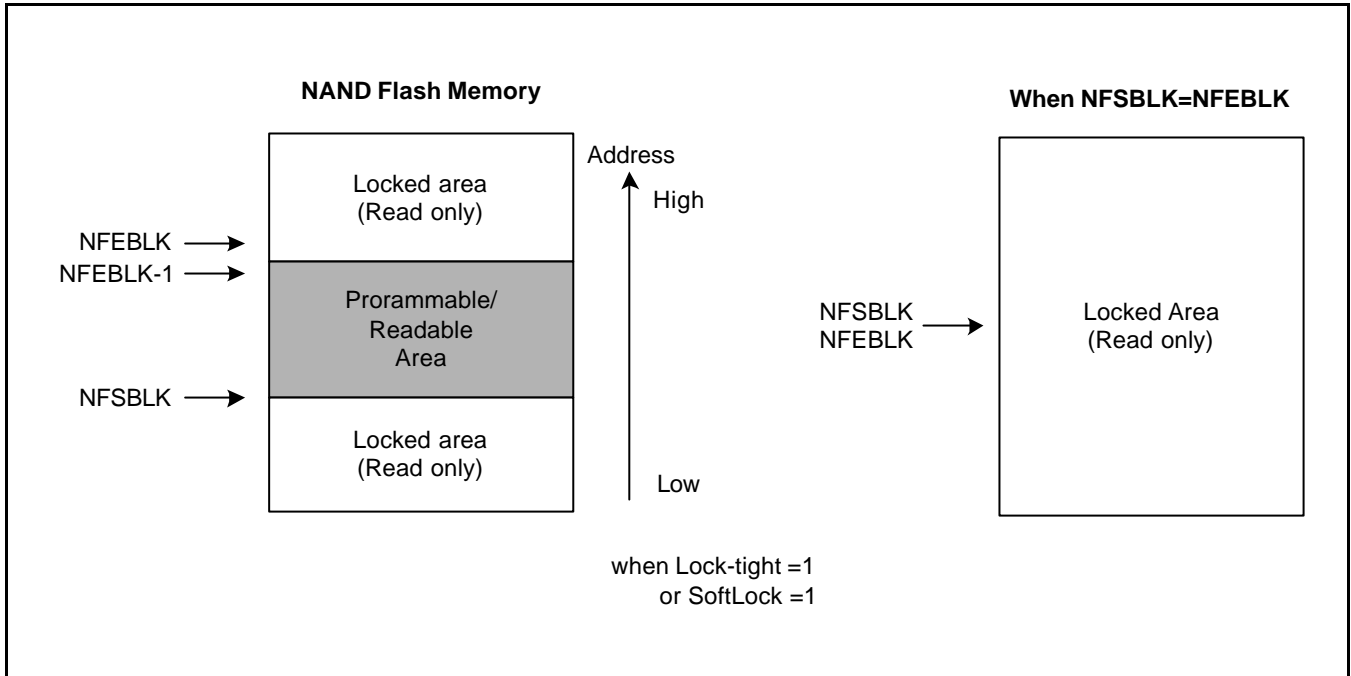

7

CLOCK & POWER MANAGEMENT

OVERVIEW

The Clock & Power management block consists of three parts: Clock control, USB control, and Power control.

The Clock control logic in S3C2440A can generate the required clock signals including FCLK for CPU, HCLK for the AHB bus peripherals, and PCLK for the APB bus peripherals. The S3C2440A has two Phase Locked Loops (PLLs): one for FCLK, HCLK, and PCLK, and the other dedicated for USB block (48Mhz). The clock control logic can make slow clocks without PLL and connect/disconnect the clock to each peripheral block by software, which will reduce the power consumption.

For the power control logic, the S3C2440A has various power management schemes to keep optimal power consumption for a given task. The power management block in the S3C2440A can activate four modes: NORMAL mode, SLOW mode, IDLE mode, and SLEEP mode.

NORMAL mode: The block supplies clocks to CPU as well as all peripherals in the S3C2440A. In this mode, the power consumption will be maximized when all peripherals are turned on. It allows the user to control the operation of peripherals by software. *For example, if a timer is not needed, the user can disconnect the clock(CLKCON register) to the timer to reduce power consumption.*

SLOW mode: Non-PLL mode. Unlike the Normal mode, the Slow mode uses an external clock (XTIpll or EXTCLK) directly as FCLK in the S3C2440A without PLL. In this mode, the power consumption depends on the frequency of the external clock only. The power consumption due to PLL is excluded.

IDLE mode: The block disconnects clocks (FCLK) only to the CPU core while it supplies clocks to all other peripherals. The IDLE mode results in reduced power consumption due to CPU core. Any interrupt request to CPU can be woken up from the Idle mode.

SLEEP mode: The block disconnects the internal power. So, there occurs no power consumption due to CPU and the internal logic except the wake-up logic in this mode. Activating the SLEEP mode requires two independent power sources. One of the two power sources supplies the power for the wake-up logic. The other one supplies other internal logics including CPU, and should be controlled for power on/off. In the SLEEP mode, the second power supply source for the CPU and internal logics will be turned off. The wakeup from SLEEP mode can be issued by the EINT[15:0] or by RTC alarm interrupt.

FUNCTIONAL DESCRIPTION

CLOCK ARCHITECTURE

Figure 7-1 shows a block diagram of the clock architecture. The main clock source comes from an external crystal (XTIpll) or an external clock (EXTCLK). The clock generator includes an oscillator (Oscillation Amplifier), which is connected to an external crystal, and also has two PLLs (Phase-Locked-Loop), which generate the high frequency clock required in the S3C2440A.

CLOCK SOURCE SELECTION

Table 7-1 shows the relationship between the combination of mode control pins (OM3 and OM2) and the selection of source clock for the S3C2440A. The OM[3:2] status is latched internally by referring the OM3 and OM2 pins at the rising edge of nRESET.

Table 7-1. Clock Source Selection at Boot-Up

Mode OM[3:2]	MPLL State	UPLL State	Main Clock source	USB Clock Source
00	On	On	Crystal	Crystal
01	On	On	Crystal	EXTCLK
10	On	On	EXTCLK	Crystal
11	On	On	EXTCLK	EXTCLK

NOTES:

- Although the MPLL starts just after a reset, the MPLL output (Mpll) is not used as the system clock until the software writes valid settings to the MPLLCON register. Before this valid setting, the clock from external crystal or EXTCLK source will be used as the system clock directly. Even if the user does not want to change the default value of MPLLCON register, the user should write the same value into MPLLCON register.
- OM[3:2] is used to determine a test mode when OM[1:0] is 11.

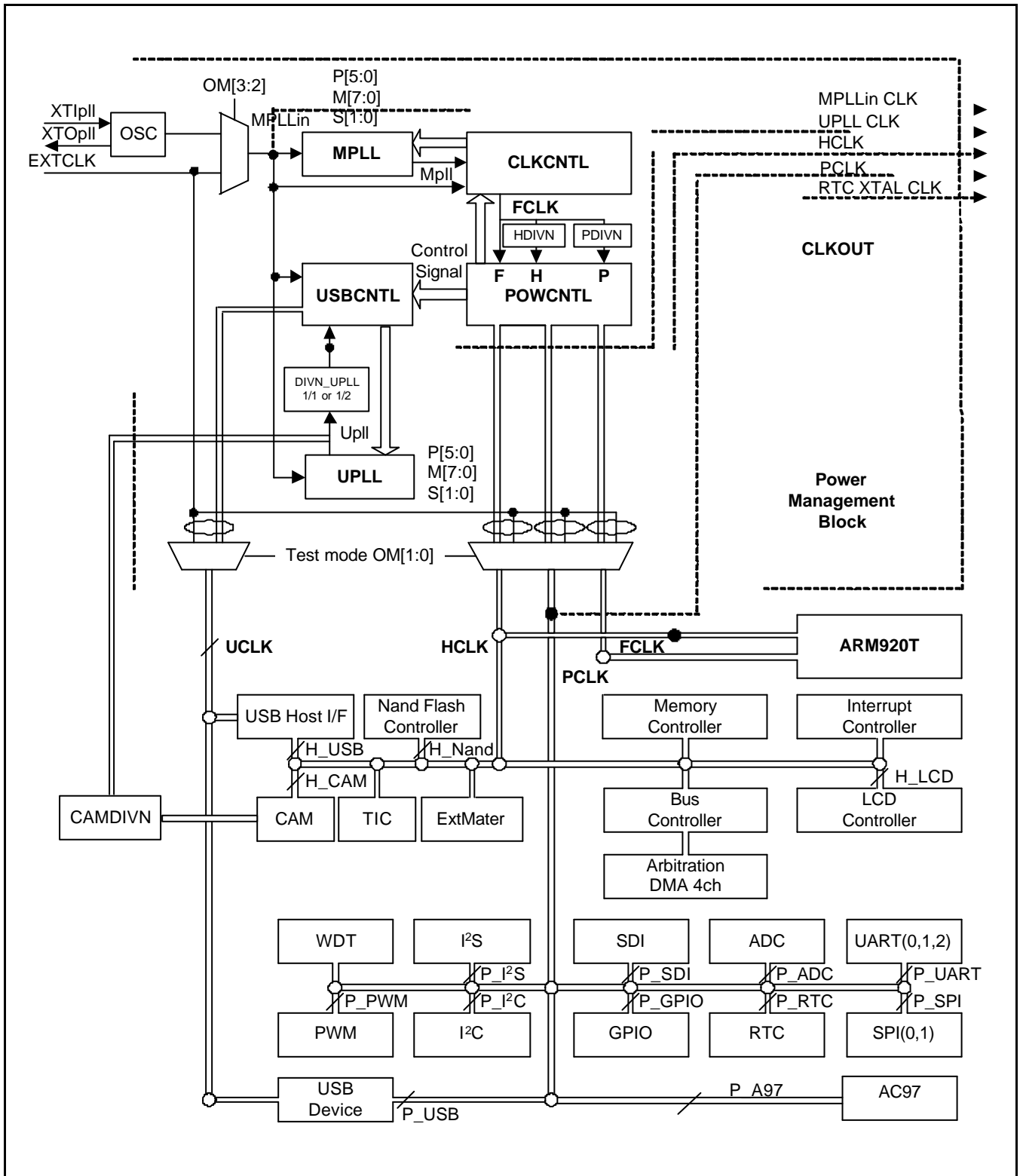

Figure 7-1. Clock Generator Block Diagram

PHASE LOCKED LOOP (PLL)

The MPLL within the clock generator, as a circuit, synchronizes an output signal with a reference input signal in frequency and phase. In this application, it includes the following basic blocks as shown in Figure 7-2: the Voltage Controlled Oscillator (VCO) to generate the output frequency proportional to input DC voltage, the divider P to divide the input frequency (F_{in}) by p, the divider M to divide the VCO output frequency by m which is input to Phase Frequency Detector (PFD), the divider S to divide the VCO output frequency by "s" which is M_{pll} (the output frequency from MPLL block), the phase difference detector, the charge pump, and the loop filter. The output clock frequency M_{pll} is related to the reference input clock frequency F_{in} by the following equation:

$$M_{pll} = (2 * m * F_{in}) / (p * 2^s)$$

$$m = M \text{ (the value for divider M)} + 8, p = P \text{ (the value for divider P)} + 2$$

The UPLL within the clock generator is similar to the MPLL in every aspect.

The following sections describes the operation of the PLL, including the phase difference detector, the charge pump, the Voltage controlled oscillator (VCO), and the loop filter.

Phase Frequency Detector (PFD)

The PFD monitors the phase difference between F_{ref} and F_{vco} , and generates a control signal (tracking signal) when the difference is detected. The F_{ref} means the reference frequency as shown in the Figure 7-2.

Charge Pump (PUMP)

The charge pump converts PFD control signals into a proportional change in voltage across the external filter that drives the VCO.

Loop Filter

The control signal, which the PFD generates for the charge pump, may generate large excursions (ripples) each time the F_{vco} is compared to the F_{ref} . To avoid overloading the VCO, a low pass filter samples and filters the high-frequency components out of the control signal. The filter is typically a single-pole RC filter with a resistor and a capacitor.

Voltage Controlled Oscillator (VCO)

The output voltage from the loop filter drives the VCO, causing its oscillation frequency to increase or decrease linearly as a function of variations in average voltage. When the F_{vco} matches F_{ref} in terms of frequency as well as phase, the PFD stops sending control signals to the charge pump, which in turn stabilizes the input voltage to the loop filter. The VCO frequency then remains constant, and the PLL remains fixed onto the system clock.

Usual Conditions for PLL & Clock Generator

PLL & Clock Generator generally uses the following conditions.

Loop filter capacitance	C_{LF}	MPLLCAP: 1.3 nF \pm 5%
		UPLLCAP: 700 pF \pm 5%
External X-tal frequency	–	12 – 20 MHz (note)
External capacitance used for X-tal	C_{EXT}	15 – 22 pF

NOTES:

1. The value could be changed.
2. $F_{CLK_{OUT}}$ must be bigger than 200MHz (It does not mean that the ARM core has to run more than 200MHz).

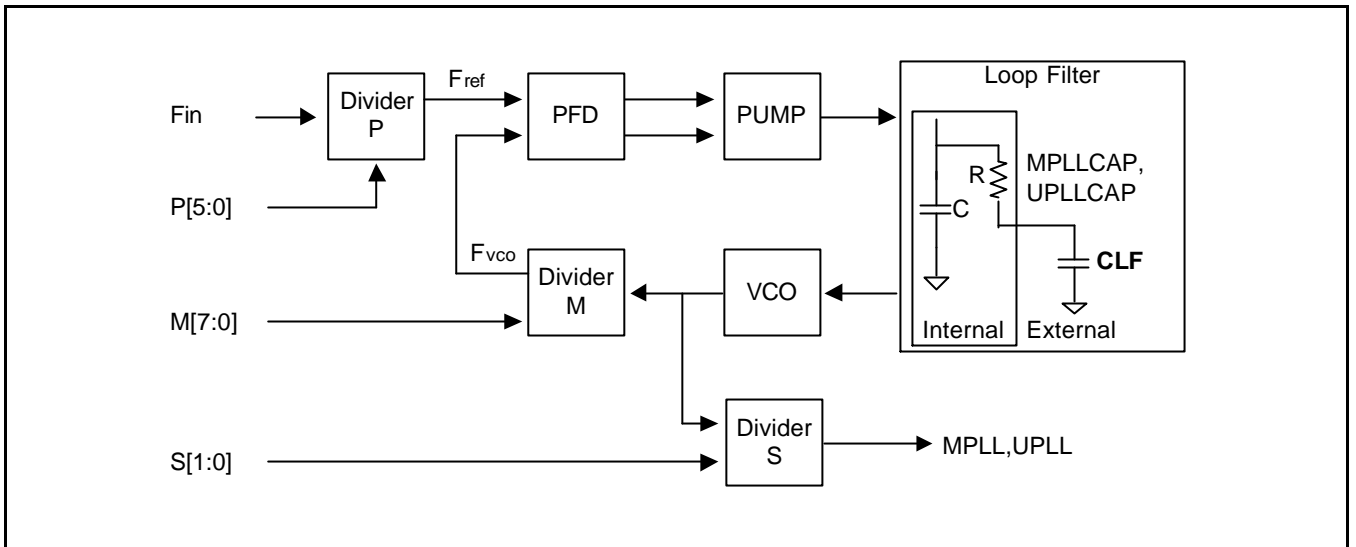

Figure 7-2. PLL (Phase-Locked Loop) Block Diagram

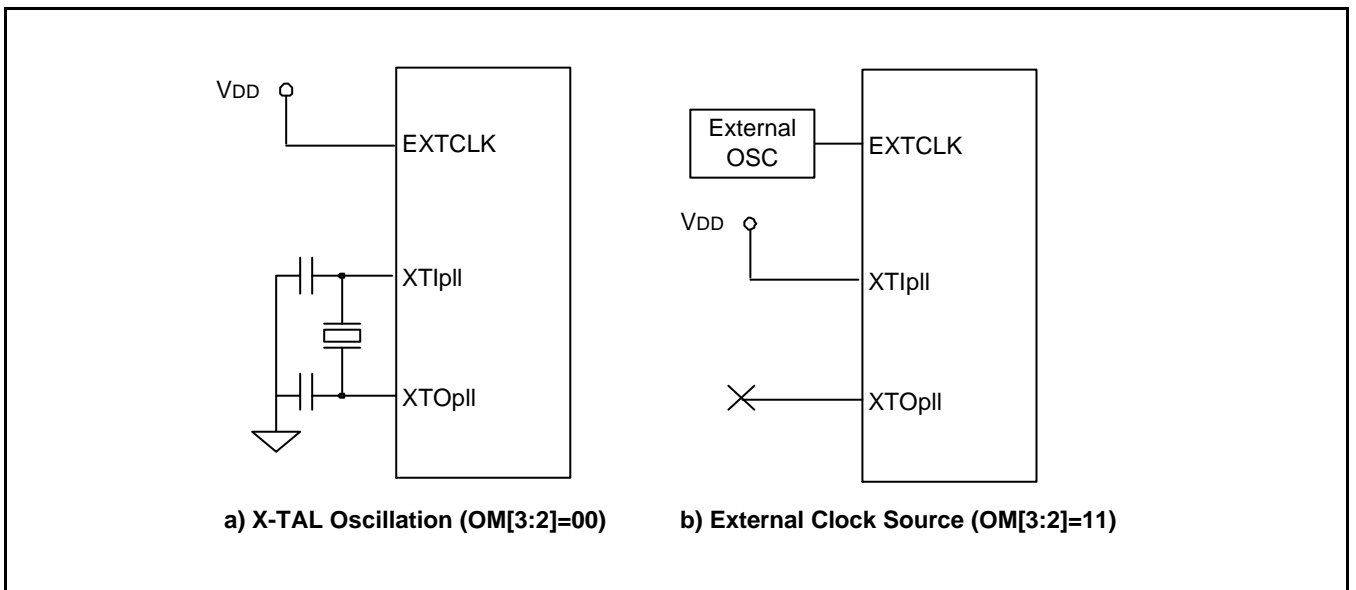

Figure 7-3. Main Oscillator Circuit Examples

CLOCK CONTROL LOGIC

The **Clock Control Logic** determines the clock source to be used, i.e., the PLL clock (Mpll) or the direct external clock (XTIpll or EXTCLK). When PLL is configured to a new frequency value, the clock control logic disables the FCLK until the PLL output is stabilized using the PLL locking time. The clock control logic is also activated at power-on reset and wakeup from power-down mode.

Power-On Reset (XTIpll)

Figure 7-4 shows the clock behavior during the power-on reset sequence. The crystal oscillator begins oscillation within several milliseconds. When nRESET is released after the stabilization of OSC (XTIpll) clock, the PLL starts to operate according to the default PLL configuration. However, PLL is commonly known to be unstable after power-on reset, so Fin is fed directly to FCLK instead of the Mpll (PLL output) before the software newly configures the PLLCON. Even if the user does not want to change the default value of PLLCON register after reset, the user should write the same value into PLLCON register by software.

The PLL restarts the lockup sequence toward the new frequency only after the software configures the PLL with a new frequency. FCLK can be configured as PLL output (Mpll) immediately after lock time.

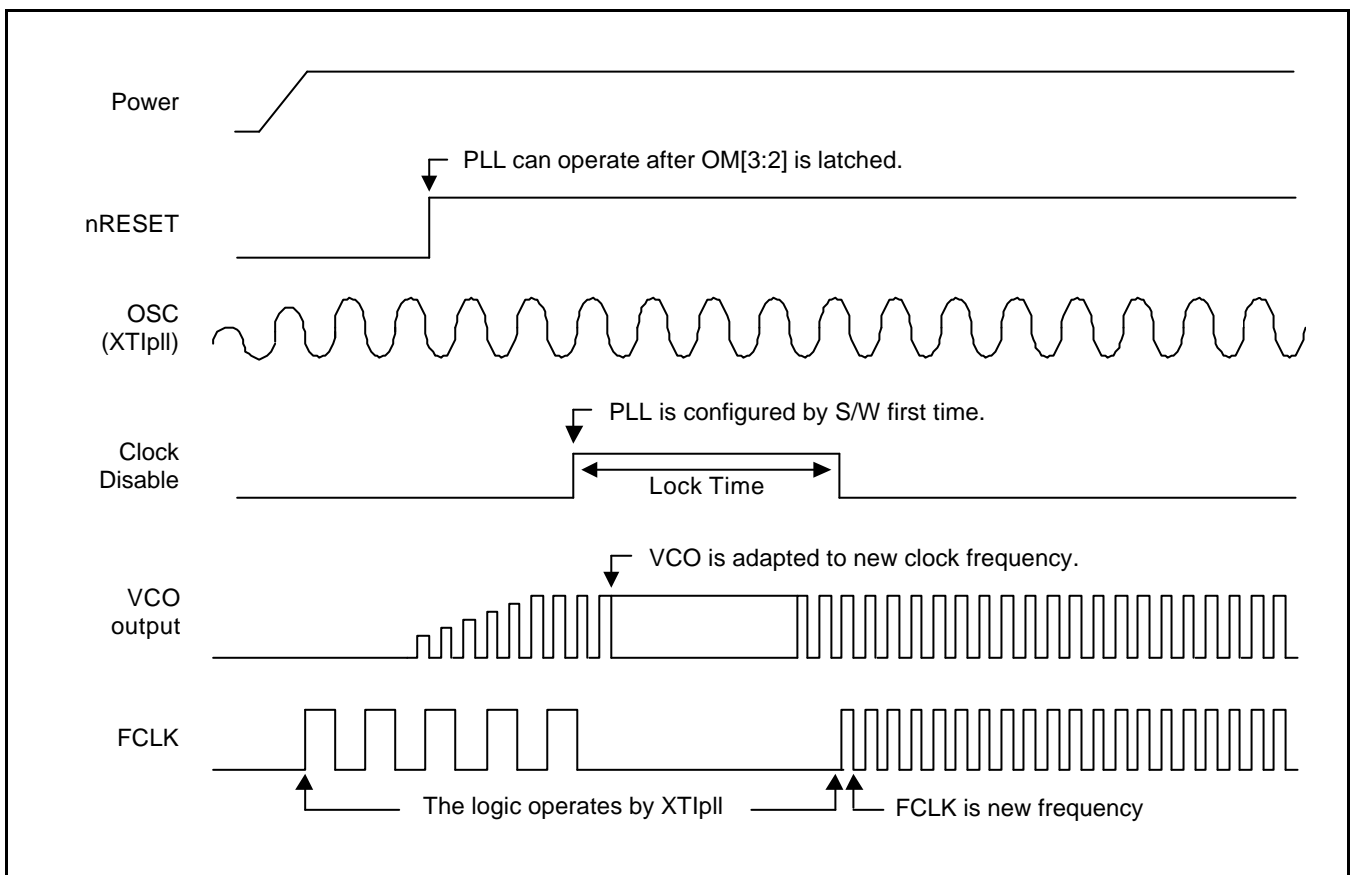

Figure 7-4. Power-On Reset Sequence (when the external clock source is a crystal oscillator)

Change PLL Settings In Normal Operation Mode

During the operation of the S3C2440A in NORMAL mode, the user can change the frequency by writing the PMS value and the PLL lock time will be automatically inserted. During the lock time, the clock is not supplied to the internal blocks in the S3C2440A. Figure 7-5 shows the timing diagram.

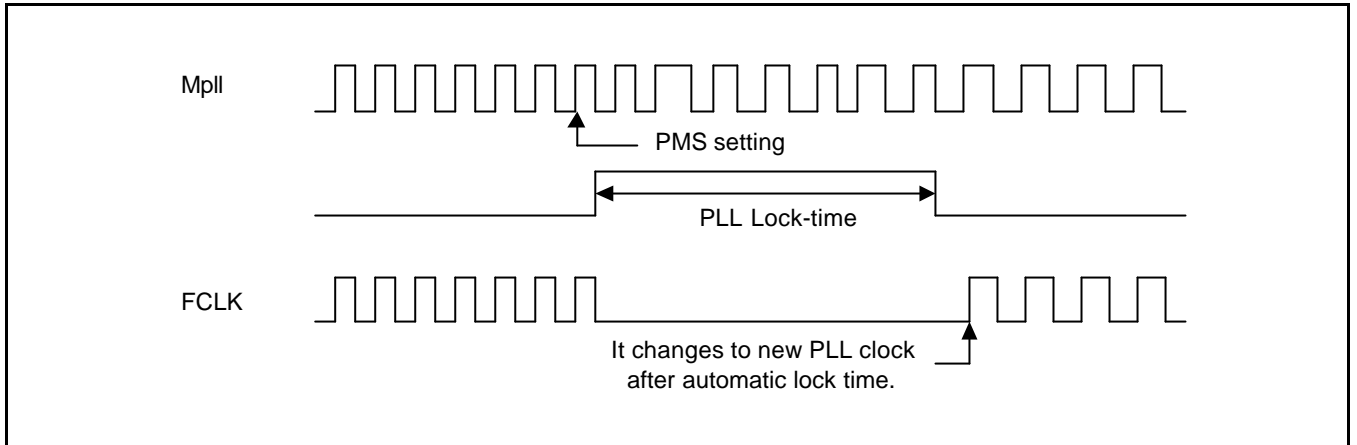

Figure 7-5. Changing Slow Clock by Setting PMS Value

USB Clock Control

USB host interface and USB device interface needs 48Mhz clock. In the S3C2440A, the USB dedicated PLL (UPLL) generates 48Mhz for USB. UCLK does not fed until the PLL (UPLL) is configured.

Condition	UCLK State	UPLL State
After reset	XTIpll or EXTCLK	On
After UPLL configuration	L: During PLL lock time 48MHz: After PLL lock time	On
UPLL is turned off by CLKSLOW register	XTIpll or EXTCLK	Off
UPLL is turned on by CLKSLOW register	48MHz	On

FCLK, HCLK, and PCLK

FCLK is used by ARM920T.

HCLK is used for AHB bus, which is used by the ARM920T, the memory controller, the interrupt controller, the LCD controller, the DMA and USB host block.

PCLK is used for APB bus, which is used by the peripherals such as WDT, IIS, I2C, PWM timer, MMC interface, ADC, UART, GPIO, RTC and SPI.

The S3C2440A supports selection of Dividing Ratio between FCLK, HCLK and PCLK. This ratio is determined by HDIVN and PDIVN of CLKDIVN control register.

HDIVN	PDIVN	HCLK3_HALF/ HCLK4_HALF	FCLK	HCLK	PCLK	Divide Ratio
0	0	–	FCLK	FCLK	FCLK	1 : 1 : 1 (Default)
0	1	–	FCLK	FCLK	FCLK / 2	1 : 1 : 2
1	0	–	FCLK	FCLK / 2	FCLK / 2	1 : 2 : 2
1	1	–	FCLK	FCLK / 2	FCLK / 4	1 : 2 : 4
3	0	0 / 0	FCLK	FCLK / 3	FCLK / 3	1 : 3 : 3
3	1	0 / 0	FCLK	FCLK / 3	FCLK / 6	1 : 3 : 6
3	0	1 / 0	FCLK	FCLK / 6	FCLK / 6	1 : 6 : 6
3	1	1 / 0	FCLK	FCLK / 6	FCLK / 12	1 : 6 : 12
2	0	0 / 0	FCLK	FCLK / 4	FCLK / 4	1 : 4 : 4
2	1	0 / 0	FCLK	FCLK / 4	FCLK / 8	1 : 4 : 8
2	0	0 / 1	FCLK	FCLK / 8	FCLK / 8	1 : 8 : 8
2	1	0 / 1	FCLK	FCLK / 8	FCLK / 16	1 : 8 : 16

After setting PMS value, it is required to set CLKDIVN register. The value set for CLKDIVN will be valid after PLL lock time. The value is also available for reset and changing Power Management Mode.

The setting value can also be valid after 1.5 HCLK. Only, 1HCLK can validate the value of CLKDIVN register changed from Default (1:1:1) to other Divide Ratio (1:1:2, 1:2:2, 1:2:4).

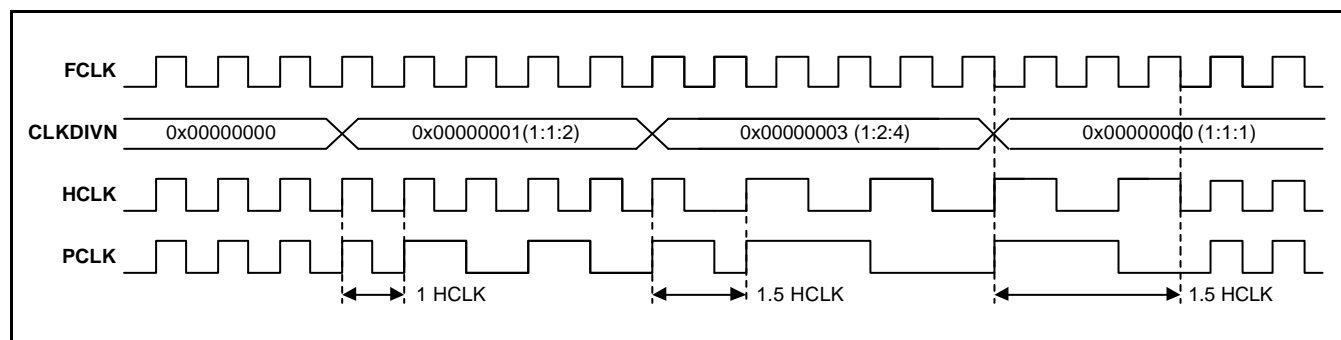

Figure 7-6. Example of Internal Clock Change

NOTES

1. CLKDIVN should be set carefully not to exceed the limit of HCLK and PCLK.
2. If HDIVN is not 0, the CPU bus mode has to be changed from the fast bus mode to the asynchronous bus mode using following instructions(S3C2440 does not support synchronous bus mode).

MMU_SetAsyncBusMode

```
mrc p15,0,r0,c1,c0,0
```

```
orr r0,r0,#R1_nF:OR:R1_iA
```

```
mcr p15,0,r0,c1,c0,0
```

If HDIVN is not 0 and the CPU bus mode is the fast bus mode, the CPU will operate by the HCLK. This feature can be used to change the CPU frequency as a half or more without affecting the HCLK and PCLK.

POWER MANAGEMENT

The Power Management block controls the system clocks by software for the reduction of power consumption in the S3C2440A. These schemes are related to PLL, clock control logics (FCLK, HCLK, and PCLK) and wakeup signals. Figure 7-7 shows the clock distribution of the S3C2440A.

The S3C2440A has four power modes. The following section describes each power management mode. The transition between the modes is not allowed freely. Please see Figure 7-8 for available transitions among the modes.

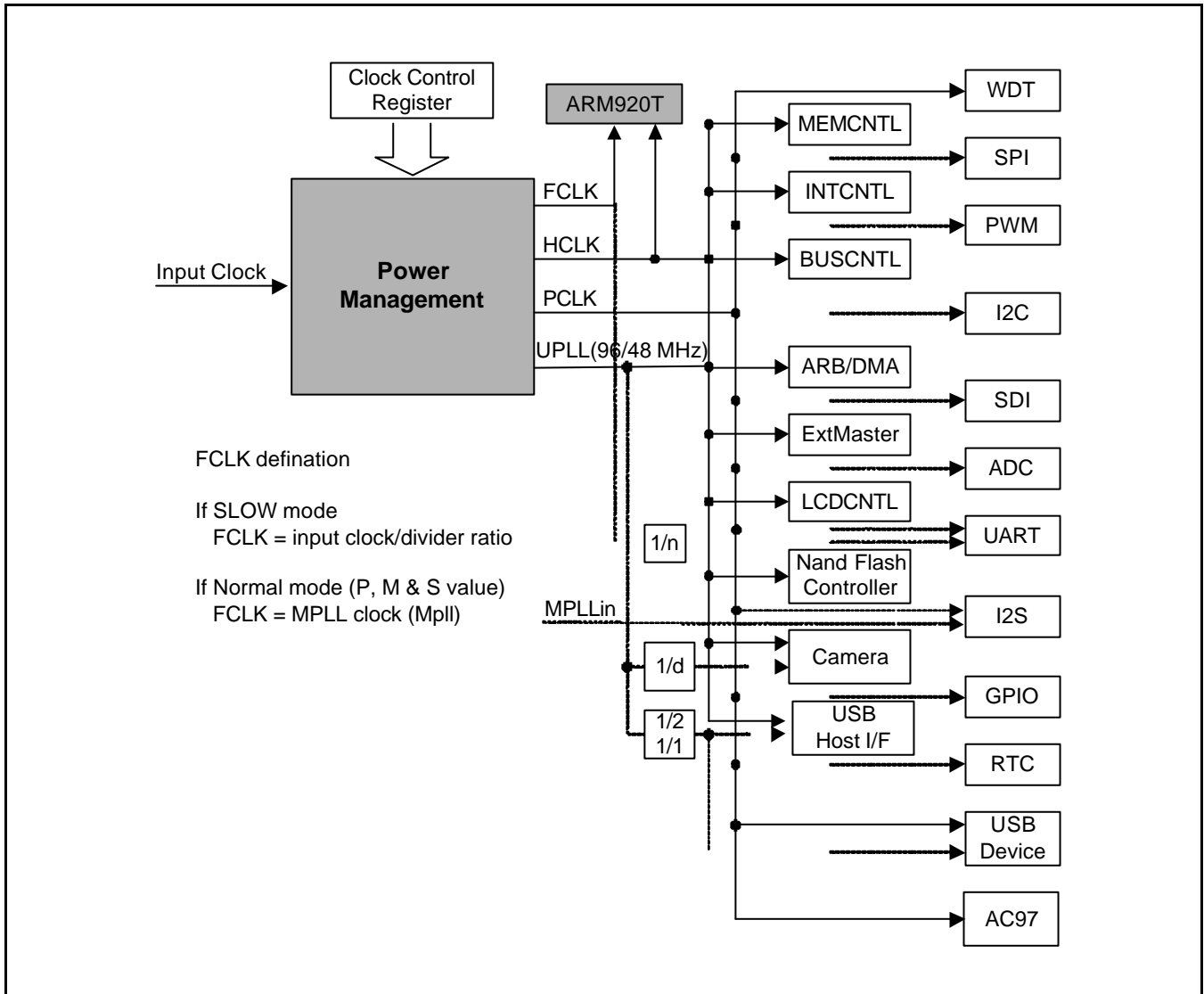

Figure 7-7. The Clock Distribution Block Diagram

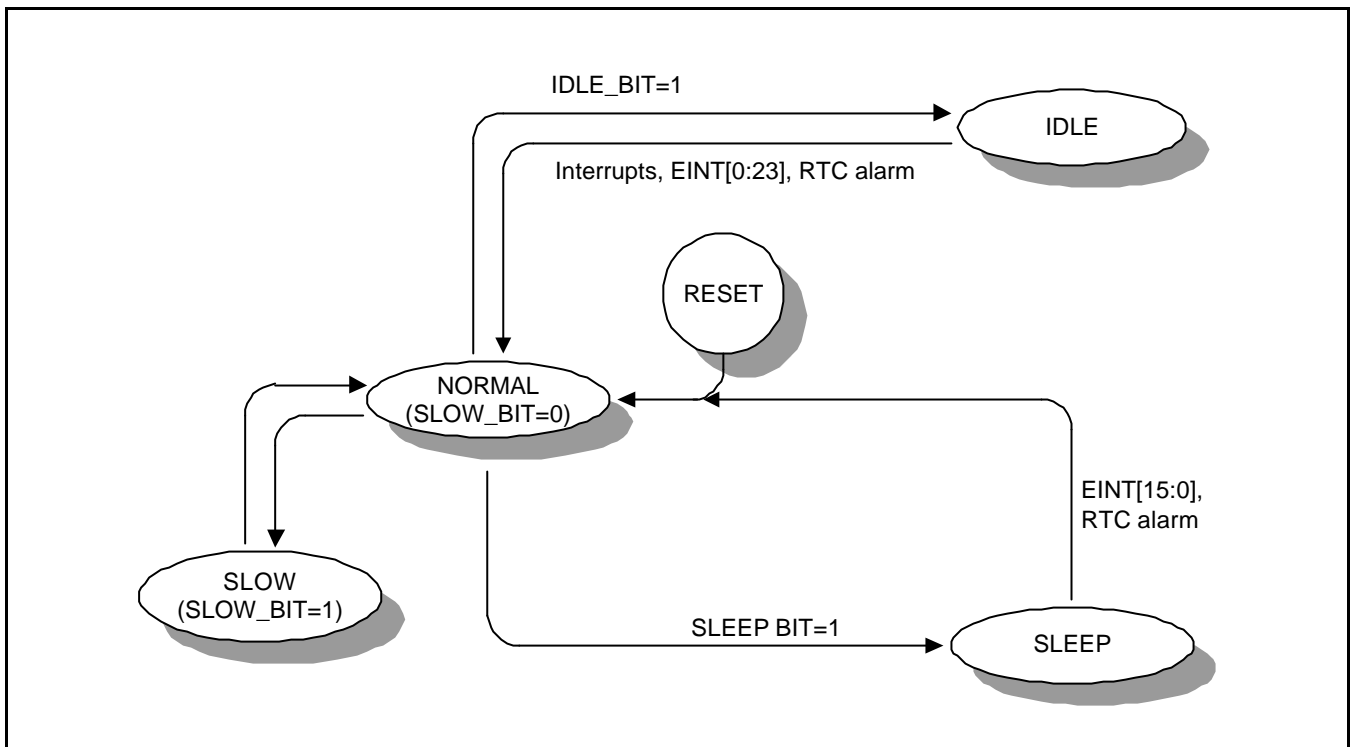

Figure 7-8. Power Management State Diagram

Table 7-2. Clock and Power State in Each Power Mode

Mode	ARM920T	AHB Modules (1) /WDT	Power Management	GPIO	32.768kHz RTC clock	APB Modules (2) & USBH/LCD/NAND
NORMAL	O	O	O	SEL	O	SEL
IDLE	X	O	O	SEL	O	SEL
SLOW	O	O	O	SEL	O	SEL
SLEEP	OFF	OFF	Wait for wake-up event	Previous state	O	OFF

NOTES:

1. USB host,LCD, and NAND are excluded.
2. WDT is excluded. RTC interface for CPU access is included.
3. SEL : selectable(O,X), O : enable , X : disable OFF: power is turned off

NORMAL Mode

In Normal mode, all peripherals and the basic blocks including power management block, the CPU core, the bus controller, the memory controller, the interrupt controller, DMA, and the external master may operate completely. But, the clock to each peripheral, except the basic blocks, can be stopped selectively by software to reduce the power consumption.

IDLE Mode

In IDLE mode, the clock to the CPU core is stopped except the bus controller, the memory controller, the interrupt controller, and the power management block. To exit the IDLE mode, EINT[23:0], or RTC alarm interrupt, or the other interrupts should be activated. (EINT is not available until GPIO block is turned on).

SLOW Mode (Non-PLL Mode)

Power consumption can be reduced in the SLOW mode by applying a slow clock and excluding the power consumption from the PLL. The FCLK is the frequency of divide_by_n of the input clock (XTIpll or EXTCLK) without PLL. The divider ratio is determined by SLOW_VAL in the CLKSLOW control register and CLKDIVN control register.

Table 7-3. CLKSLOW and CLKDIVN Register Settings for SLOW Clock example

SLOW_VAL	FCLK	HCLK		PCLK		UCLK
		1/1 Option (HDIVN=0)	1/2 Option (HDIVN=1)	1/1 Option (PDIVN=0)	1/2 Option (PDIVN=1)	
0 0 0	EXTCLK or XTIpll / 1	EXTCLK or XTIpll / 1	EXTCLK or XTIpll / 2	HCLK	HCLK / 2	48 MHz
0 0 1	EXTCLK or XTIpll / 2	EXTCLK or XTIpll / 2	EXTCLK or XTIpll / 4	HCLK	HCLK / 2	48 MHz
0 1 0	EXTCLK or XTIpll / 4	EXTCLK or XTIpll / 4	EXTCLK or XTIpll / 8	HCLK	HCLK / 2	48 MHz
0 1 1	EXTCLK or XTIpll / 6	EXTCLK or XTIpll / 6	EXTCLK or XTIpll / 12	HCLK	HCLK / 2	48 MHz
1 0 0	EXTCLK or XTIpll / 8	EXTCLK or XTIpll / 8	EXTCLK or XTIpll / 16	HCLK	HCLK / 2	48 MHz
1 0 1	EXTCLK or XTIpll / 10	EXTCLK or XTIpll / 10	EXTCLK or XTIpll / 20	HCLK	HCLK / 2	48 MHz
1 1 0	EXTCLK or XTIpll / 12	EXTCLK or XTIpll / 12	EXTCLK or XTIpll / 24	HCLK	HCLK / 2	48 MHz
1 1 1	EXTCLK or XTIpll / 14	EXTCLK or XTIpll / 14	EXTCLK or XTIpll / 28	HCLK	HCLK / 2	48 MHz

In SLOW mode, PLL will be turned off to reduce the PLL power consumption. When the PLL is turned off in the SLOW mode and the user changes power mode from SLOW mode to NORMAL mode, then the PLL needs clock stabilization time (PLL lock time). This PLL stabilization time is automatically inserted by the internal logic with lock time count register. The PLL stability time will take 300us after the PLL is turned on. During PLL lock time, the FCLK becomes SLOW clock.

Users can change the frequency by enabling SLOW mode bit in CLKSLOW register in PLL on state. The SLOW clock is generated during the SLOW mode. Figure 7-11(Please check the figure correctly) shows the timing diagram.

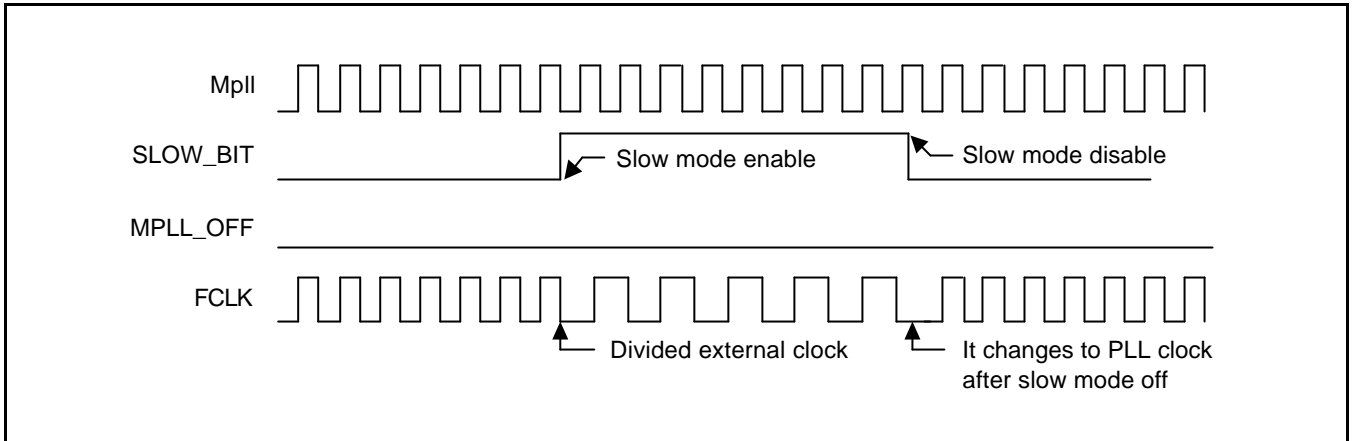

Figure 7-9. Issuing Exit_from_Slow_mode Command in PLL on State

If the user switches from SLOW mode to Normal mode by disabling the SLOW_BIT in the CLKSLOW register after PLL lock time, the frequency is changed just after SLOW mode is disabled. Figure 7-12 (Please check for the figure number correctly) shows the timing diagram.

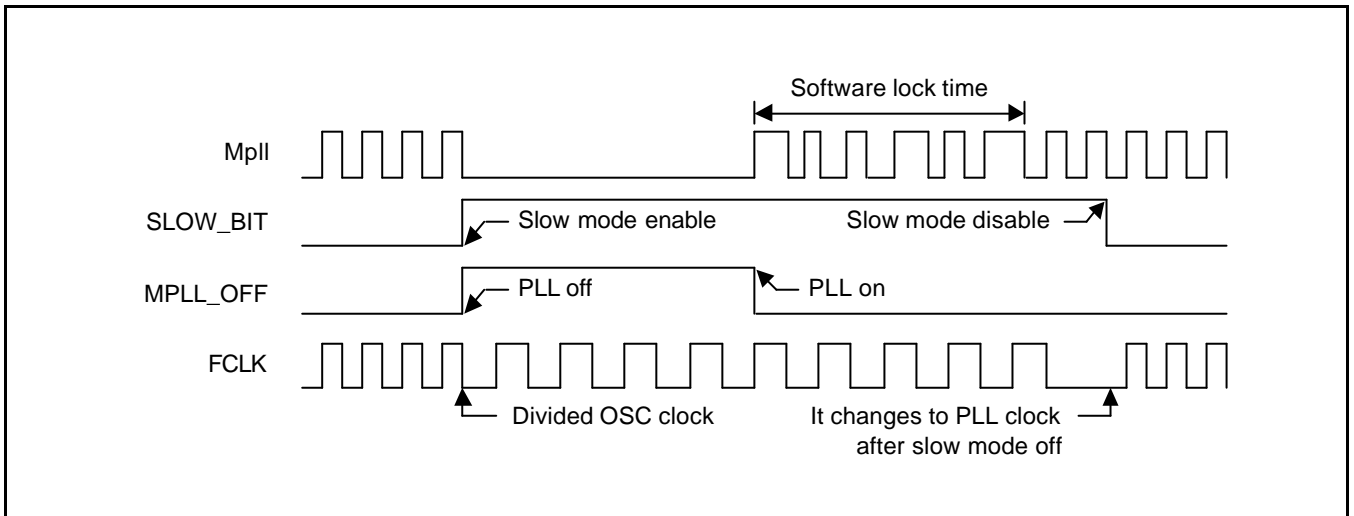

Figure 7-10. Issuing Exit_from_Slow_mode Command After Lock Time

If the user switches from SLOW mode to Normal mode by disabling SLOW_BIT and MPLL_OFF bit simultaneously in the CLKSLOW register, the frequency is changed just after the PLL lock time. Figure 7-13 (Please check for the figure number correctly) shows the timing diagram.

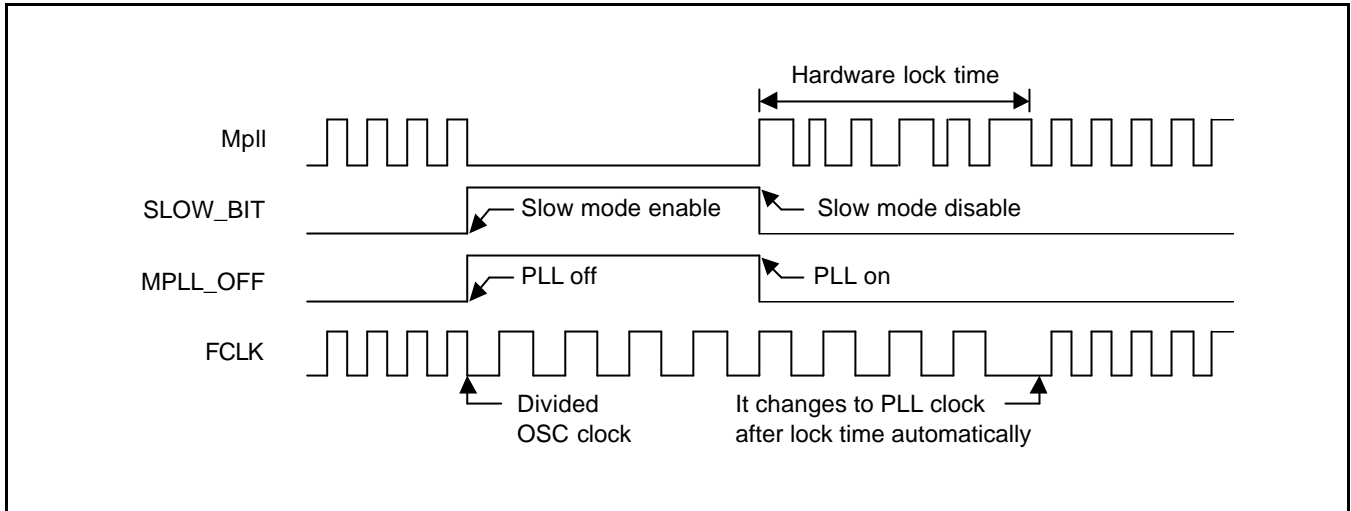

Figure 7-11. Issuing Exit_from_Slow_mode Command and the Instant PLL_on Command Simultaneously

SLEEP Mode

The block disconnects the internal power. So, there occurs no power consumption due to CPU and the internal logic except the wake-up logic in this mode. Activating the SLEEP mode requires two independent power sources. One of the two power sources supplies the power for the wake-up logic. The other one supplies other internal logics including CPU, and should be controlled for power on/off. In the SLEEP mode, the second power supply source for the CPU and internal logics will be turned off. The wakeup from SLEEP mode can be issued by the EINT[15:0] or by RTC alarm interrupt.

Follow the Procedure to Enter SLEEP mode

1. Set the GPIO configuration adequate for SLEEP mode.
2. Mask all interrupts in the INTMSK register.
3. Configure the wake-up sources properly including RTC alarm. (The bit of EINTMASK corresponding to the wake-up source has not to be masked in order to let the corresponding bit of SRCPND or EINTPEND set. Although a wake-up source is issued and the corresponding bit of EINTMASK is masked, the wake-up will occur and the corresponding bit of SRCPND or EINTPEND will not be set.)
4. Set USB pads as suspend mode. (MISCCR[13:12]=11b)
5. Save some meaning values into GSTATUS[4:3] register. These register are preserved during SLEEP mode.
6. Configure MISCCR[1:0] for the pull-up resistors on the data bus,D[31:0]. If there is an external BUS holder, such as 74LVCH162245, turn off the pull-up resistors. If not, turn on the pull-up resistors.
Additionally, The Memory concerning pins is set to two types, one is Hi-z, and the other is Inactive state.
7. Stop LCD by clearing LCDCON1.ENVID bit.
8. Read rREFRESH and rCLKCON registers in order to fill the TLB.
9. Let SDRAM enter the self-refresh mode by setting the REFRESH[22]=1b.
10. Wait until SDRAM self-refresh is effective.
11. Set MISCCR[19:17]=111b to make SDRAM signals(SCLK0,SCLK1 and SCKE) protected during SLEEP mode
12. Set the SLEEP mode bit in the CLKCON register.

Caution: When the system is operating in NAND boot mode, The hardware pin configuration - EINT[23:21] – must be set as input for starting up after wakeup from sleep mode.

Follow the Procedure to Wake-up from SLEEP mode

1. The internal reset signal will be asserted if one of the wake-up sources is issued. It's exactly same with the case of the assertion of the external nRESET pin. This reset duration is determined by the internal 16-bit counter logic and the reset assertion time is calculated as $t_{RST} = (65535 / XTAL_frequency)$.
2. Check GSTATUS2[2] in order to know whether or not the power-up is caused by the wake-up from SLEEP mode.
3. Release the SDRAM signal protection by setting MISCCR[19:17]=000b.
4. Configure the SDRAM memory controller.
5. Wait until the SDRAM self-refresh is released. Mostly SDRAM needs the refresh cycle of all SDRAM row.
6. The information in GSTATUS[3:4] can be used for user's own purpose because the value in GSTATUS[3:4] has been preserved during SLEEP mode.
7.
 - For EINT[3:0], check the SRCPND register.
 - For EINT[15:4], check the EINTPEND instead of SRCPND (SRCPND will not be set although some bits of EINTPEND are set.).

Table 7-4. Pin configuration table in Sleep mode

Pin Condition		Guid of Pin Configuration	
GPIO Pin	which are configured as input	Pull-up enable	
	which are configured as output	Pull-up disable and output low	
Input pin, which doesn't have internal pull-up control.	If external device doesn't always drive pin's level.	Pull-up enable by external pull-up resistor	
Output pin, which are connected to external device	If external device's power is off	Output low	
	If external device's power is on	High or low (It depends on External device's status)	
Data Bus	If memory power is off		Output low
	If memory power is on	and external buffer does exist	If buffer can hold bus level, pull-up disable.
		and no external buffer	Output low

NOTE:

1. ADC should be set to Standby mode.
2. USB pads should be Suspend mode.

* This table is just for informational use only. User should consider his own board condition and application.

Power Control of VDDi and VDDiarm

In SLEEP mode, VDDi, VDDiarm, VDDMPLL and VDDUPLL will be turned off, which is controlled by PWREN pin.

If PWREN signal is activated(H), VDDi and VDDiarm are supplied by an external voltage regulator. If PWREN pin is inactive (L), the VDDi and VDDiarm are turned off.

NOTE

Although VDDi, VDDiarm, VDDMPLL and VDDUPLL may be turned off, the other power pins have to be supplied.

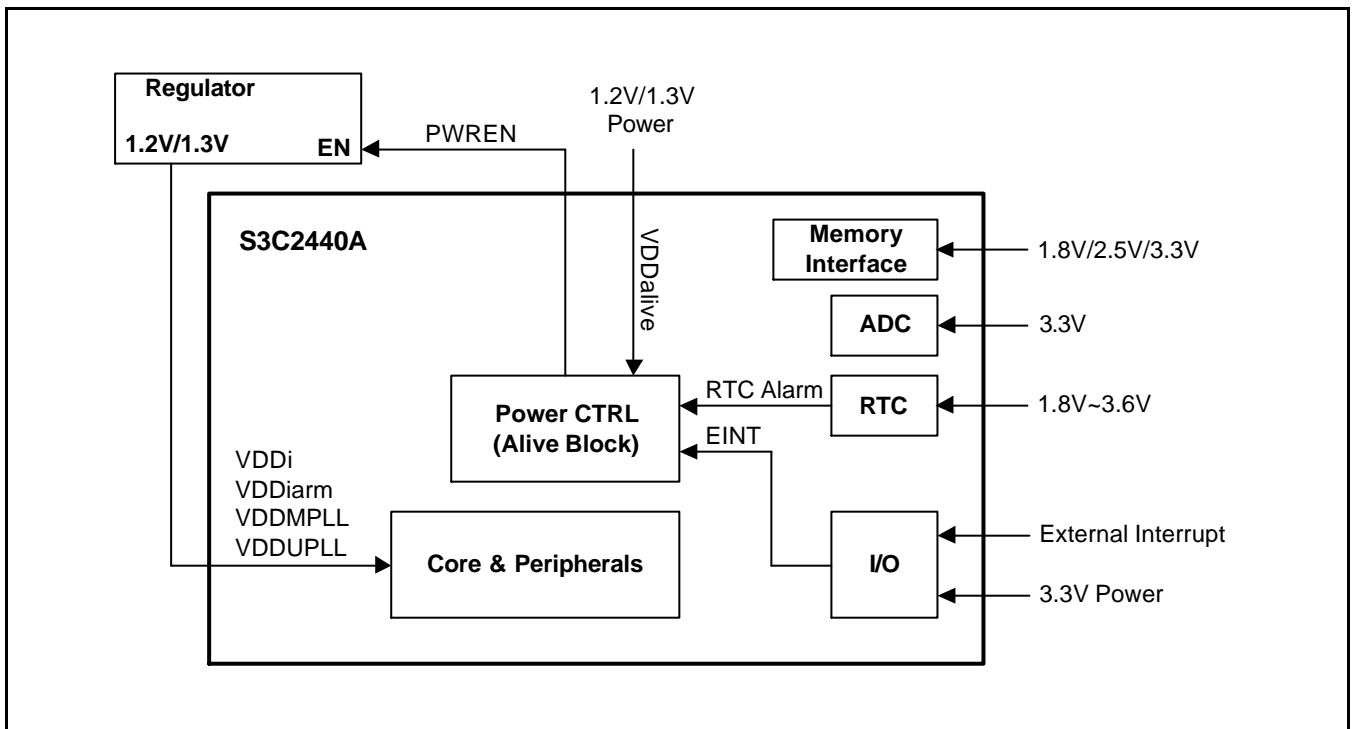

Figure 7-12. SLEEP Mode

NOTE

During sleep mode, if you don't use Touch Screen panel, Touch ports (XP, XM, YP, and YM) must be floating. That is, Touch ports (XP, XM, YP, and YM) shouldn't be connected to GND sources. Because XP,YP will be maintained H during sleep mode.

Signaling EINT[15:0] for Wakeup

The S3C2440A can be woken up from SLEEP mode only if the following conditions are met.

- a) Level signals (H or L) or edge signals (rising, falling or both) are asserted on EINTn input pin.
- b) The EINTn pin has to be configured as EINT in the GPIO control register.
- c) nBATT_FLT pin has to be H level. It is important to configure the EINTn in the GPIO control register as an external interrupt pins, considering the condition a) above.

Just after the wake-up, the corresponding EINTn pin will not be used for wakeup. This means that the pin can be used as an external interrupt request pin again.

Entering IDLE Mode

If CLKCON[2] is set to 1 to enter the IDLE mode, the S3C2440A will enter IDLE mode after some delay (until the power control logic receives ACK signal from the CPU wrapper).

PLL On/Off

The PLL can only be turned off for low power consumption in slow mode. If the PLL is turned off in any other mode, MCU operation is not guaranteed.

When the processor is in SLOW mode and tries to change its state into other state with the PLL turned on, then SLOW_BIT should be clear to move to another state after PLL stabilization

Pull-up Resistors on the Data Bus and SLEEP Mode

In SLEEP mode, the data bus (D[31:0] or D[15:0]) can be selected as Hi-z state and Output Low state.

The data bus can be set as Hi-z status with turning on pull-up register or can be set as output low with turning off pull-up register for low power consumption in SLEEP mode. D[31:0] pin pull-up resistors can be controlled by the GPIO control register (MISCCR). However, if there is an external bus holder, such as 74LVCH162245, on the data bus, User can select one of two status – one is output low with pull-up off, the other is Hi-z with pull-up off - , which consumes less power.

Output Port State and SLEEP Mode

The output port should have a proper logic level in power off mode, which makes the current consumption minimized. If there is no load on an output port pin, H level is preferred. If output is L, the current will be consumed through the internal parasitic resistance; if the output is H, the current will not be consumed. For an output port, the current consumption can be reduced if the output state is H.

It is recommended that the output ports be in H state to reduce current consumption in SLEEP mode.

Battery Fault Signal (nBATT_FLT)

There are two functions in nBATT_FLT pin, they are as follows;

- When CPU is not in SLEEP mode, nBATT_FLT pin will cause the interrupt request by setting BATT_FUNC(MISCCR[22:20]) as 10x'b. The interrupt attribute of the nBATT_FLT is L-level triggered.
- While CPU is in SLEEP mode, assertion of the nBATT_FLT will prohibit the wake up from the sleep mode, which is achieved by setting BATT_FUNC(MISCCR[22:20]) as 11x'b. So, Any wake-up source will be masked if nBATT_FLT is asserted, which is protecting the system malfunction of the low battery capacity

ADC Power Down

The ADC has an additional power-down bit in ADCCON. If the S3C2440A enters the SLEEP mode, the ADC should enter its own power-down mode.

CLOCK GENERATOR & POWER MANAGEMENT SPECIAL REGISTER

LOCK TIME COUNT REGISTER (LOCKTIME)

Register	Address	R/W	Description	Reset Value
LOCKTIME	0x4C000000	R/W	PLL lock time count register	0xFFFFFFFF

LOCKTIME	Bit	Description	Initial State
U_LTIME	[31:16]	UPLL lock time count value for UCLK. (U_LTIME > 300uS)	0xFFFF
M_LTIME	[15:0]	MPLL lock time count value for FCLK, HCLK, and PCLK (M_LTIME > 300uS)	0xFFFF

MPLL Control Register

$$M_{pll} = (2 * m * F_{in}) / (p * 2^s)$$

$$m = (MDIV + 8), p = (PDIV + 2), s = SDIV$$

UPLL Control Register

$$U_{pll} = (m * F_{in}) / (p * 2^s)$$

$$m = (MDIV + 8), p = (PDIV + 2), s = SDIV$$

PLL Value Selection Guide (MPLLCON)

- $F_{OUT} = 2 * m * F_{in} / (p * 2^s)$, $F_{VCO} = 2 * m * F_{in} / p$ where: $m=MDIV+8$, $p=PDIV+2$, $s=SDIV$
- $600MHz \leq F_{VCO} \leq 1.2GHz$
- $200MHz \leq F_{CLK_{OUT}} \leq 600MHz$
- Don't set the P or M value as zero, that is, setting the P=000000, M=00000000 can cause malfunction of the PLL.
- The proper range of P and M: $1 \leq P \leq 62$, $1 \leq M \leq 248$

NOTE

Although there is the rule for choosing PLL value, we recommend only the values in the PLL value recommendation table. If you have to use another value, please contact us.

PLL CONTROL REGISTER (MPLLCON & UPLLCON)

Register	Address	R/W	Description	Reset Value
MPLLCON	0x4C000004	R/W	MPLL configuration register	0x00096030
UPLLCON	0x4C000008	R/W	UPLL configuration register	0x0004d030

PLLCON	Bit	Description	Initial State
MDIV	[19:12]	Main divider control	0x96 / 0x4d
PDIV	[9:4]	Pre-divider control	0x03 / 0x03
SDIV	[1:0]	Post divider control	0x0 / 0x0

NOTE: When you set MPLL&UPLL values, you have to set the UPLL value first and then the MPLL value. (Needs intervals approximately 7 NOP)

PLL VALUE SELECTION TABLE

It is not easy to find a proper PLL value. So, we recommend referring to the following PLL value recommendation table.

Input Frequency	Output Frequency	MDIV	PDIV	SDIV
12.0000MHz	48.00 MHz (Note)	56(0x38)	2	2
12.0000MHz	96.00 MHz (Note)	56(0x38)	2	1
12.0000MHz	271.50 MHz	173(0xad)	2	2
12.0000MHz	304.00 MHz	68(0x44)	1	1
12.0000MHz	405.00 MHz	127(0x7f)	2	1
12.0000MHz	532.00 MHz	125(0x7d)	1	1
16.9344MHz	47.98 MHz (Note)	60(0x3c)	4	2
16.9344MHz	95.96 MHz (Note)	60(0x3c)	4	1
16.9344MHz	266.72 MHz	118(0x76)	2	2
16.9344MHz	296.35 MHz	97(0x61)	1	2
16.9344MHz	399.65 MHz	110(0x6e)	3	1
16.9344MHz	530.61 MHz	86(0x56)	1	1
16.9344MHz	533.43 MHz	118(0x76)	1	1

NOTE: The 48.00MHz and 96MHz output is used for UPLLCON register.

CLOCK CONTROL REGISTER (CLKCON)

Register	Address	R/W	Description	Reset Value
CLKCON	0x4C00000C	R/W	Clock generator control register	0xFFFFF0

CLKCON	Bit	Description	Initial State
AC97	[20]	Control PCLK into AC97 block. 0 = Disable, 1 = Enable	1
Camera	[19]	Control HCLK into Camera block. 0 = Disable, 1 = Enable	1
SPI	[18]	Control PCLK into SPI block. 0 = Disable, 1 = Enable	1
IIS	[17]	Control PCLK into IIS block. 0 = Disable, 1 = Enable	1
IIC	[16]	Control PCLK into IIC block. 0 = Disable, 1 = Enable	1
ADC(&Touch Screen)	[15]	Control PCLK into ADC block. 0 = Disable, 1 = Enable	1
RTC	[14]	Control PCLK into RTC control block. Even if this bit is cleared to 0, RTC timer is alive. 0 = Disable, 1 = Enable	1
GPIO	[13]	Control PCLK into GPIO block. 0 = Disable, 1 = Enable	1
UART2	[12]	Control PCLK into UART2 block. 0 = Disable, 1 = Enable	1
UART1	[11]	Control PCLK into UART1 block. 0 = Disable, 1 = Enable	1
UART0	[10]	Control PCLK into UART0 block. 0 = Disable, 1 = Enable	1
SDI	[9]	Control PCLK into SDI interface block. 0 = Disable, 1 = Enable	1
PWMTIMER	[8]	Control PCLK into PWMTIMER block. 0 = Disable, 1 = Enable	1
USB device	[7]	Control PCLK into USB device block. 0 = Disable, 1 = Enable	1
USB host	[6]	Control HCLK into USB host block. 0 = Disable, 1 = Enable	1
LCDC	[5]	Control HCLK into LCDC block. 0 = Disable, 1 = Enable	1
NAND Flash Controller	[4]	Control HCLK into NAND Flash Controller block. 0 = Disable, 1 = Enable	1
SLEEP	[3]	Control SLEEP mode of S3C2440A. 0 = Disable, 1 = Transition to SLEEP mode	0
IDLE BIT	[2]	Enter IDLE mode. This bit is not cleared automatically. 0 = Disable, 1 = Transition to IDLE mode	0
Reserved	[1:0]	Reserved	0

CLOCK SLOW CONTROL (CLKSLOW) REGISTER

Register	Address	R/W	Description	Reset Value
CLKSLOW	0x4C000010	R/W	Slow clock control register	0x00000004

CLKSLOW	Bit	Description	Initial State
UCLK_ON	[7]	0: UCLK ON (UPLL is also turned on and the UPLL lock time is inserted automatically.) 1: UCLK OFF (UPLL is also turned off.)	0
Reserved	[6]	Reserved	–
MPLL_OFF	[5]	0: Turn on PLL. After PLL stabilization time (minimum 300us), SLOW_BIT can be cleared to 0. 1: Turn off PLL. PLL is turned off only when SLOW_BIT is 1.	0
SLOW_BIT	[4]	0 : FCLK = Mpll (MPLL output) 1: SLOW mode FCLK = input clock/(2xSLOW_VAL), when SLOW_VAL>0 FCLK = input clock, when SLOW_VAL=0. Input clock = XTlpll or EXTCLK	0
Reserved	[3]	–	–
SLOW_VAL	[2:0]	The divider value for the slow clock when SLOW_BIT is on.	0x4

CLOCK DIVIDER CONTROL (CLKDIVN) REGISTER

Register	Address	R/W	Description	Reset Value
CLKDIVN	0x4C000014	R/W	Clock divider control register	0x00000000

CLKDIVN	Bit	Description	Initial State
DIVN_UPLL	[3]	UCLK select register(UCLK must be 48MHz for USB) 0: UCLK = UPLL clock 1: UCLK = UPLL clock / 2 Set to 0, when UPLL clock is set as 48MHz Set to 1. when UPLL clock is set as 96MHz.	0
HDIVN	[2:1]	00 : HCLK = FCLK/1. 01 : HCLK = FCLK/2. 10 : HCLK = FCLK/4 when CAMDIVN[9] = 0. HCLK= FCLK/8 when CAMDIVN[9] = 1. 11 : HCLK = FCLK/3 when CAMDIVN[8] = 0. HCLK = FCLK/6 when CAMDIVN[8] = 1.	00
PDIVN	[0]	0: PCLK has the clock same as the HCLK/1. 1: PCLK has the clock same as the HCLK/2.	0

CAMERA CLOCK DIVIDER (CAMDIVN) REGISTER

Register	Address	R/W	Description	Reset Value
CAMDIVN	0x4C000018	R/W	Camera clock divider register	0x00000000

CAMDIVN	Bit	Description	Initial State
DVS_EN	[12]	0:DVS OFF ARM core will run normally with FCLK (MPLLout). 1:DVS ON ARM core will run at the same clock as system clock (HCLK).	0
Reserved	[11]	–	0
Reserved	[10]	–	0
HCLK4_HALF	[9]	HDIVN division rate change bit, when CLKDIVN[2:1]=10b. 0: HCLK = FCLK/4 1: HCLK= FCLK/8 Refer the CLKDIV register.	0
HCLK3_HALF	[8]	HDIVN division rate change bit, when CLKDIVN[2:1]=11b. 0: HCLK = FCLK/3 1: HCLK= FCLK/6 Refer the CLKDIV register.	0
CAMCLK_SEL	[4]	0:Use CAMCLK with UPLL output (CAMCLK=UPLL output). 1:CAMCLK is divided by CAMCLK_DIV value.	0
CAMCLK_DIV	[3:0]	CAMCLK divide factor setting register(0 – 15). Camera clock = UPLL / [(CAMCLK_DIV +1)x2]. This bit is valid when CAMCLK_SEL=1.	0

8

DMA

OVERVIEW

The S3C2440A supports four-channel DMA controller located between the system bus and the peripheral bus. Each channel of DMA controller can perform data movements between devices in the system bus and/or peripheral bus with no restrictions. In other words, each channel can handle the following four cases:

1. Both source and destination are in the system bus
2. The source is in the system bus while the destination is in the peripheral bus
3. The source is in the peripheral bus while the destination is in the system bus
4. Both source and destination are in the peripheral bus

The main advantage of the DMA is that it can transfer the data without CPU intervention. The operation of DMA can be initiated by software, or requests from internal peripherals or external request pins.

DMA REQUEST SOURCES

Each channel of the DMA controller can select one of the DMA request source among four DMA sources, if H/W DMA request mode is selected by DCON register. (Note that if S/W request mode is selected, this DMA request sources have no meaning at all.) Table 8-1 shows four DMA sources for each channel.

Table 8-1. DMA Request Sources for Each Channel

	Source0	Source1	Source2	Source3	Source4	Source5	Source6
Ch-0	nXDREQ0	UART0	SDI	Timer	USB device EP1	I2SSDO	PCMIN
Ch-1	nXDREQ1	UART1	I2SSDI	SPI0	USB device EP2	PCMOUT	SDI
Ch-2	I2SSDO	I2SSDI	SDI	Timer	USB device EP3	PCMIN	MICIN
Ch-3	UART2	SDI	SPI1	Timer	USB device EP4	MICIN	PCMOUT

Here, nXDREQ0 and nXDREQ1 represent two external sources (External Devices), and I2SSDO and I2SSDI represent IIS transmitting and receiving, respectively.

DMA OPERATION

DMA uses three-state **FSM** (Finite State Machine) for its operation, which is described in the three following steps:

- State-1. As an initial state, the DMA waits for a DMA request. Once the request is reached it goes to state-2. At this state, DMA ACK and INT REQ are 0.
- State-2. In this state, DMA ACK becomes 1 and the counter (CURR_TC) is loaded from DCON[19:0] register. Note that the DMA ACK remains 1 until it is cleared later.
- State-3. In this state, sub-FSM which handles the atomic operation of DMA is initiated. The sub-FSM reads the data from the source address and then writes it to destination address. In this operation, data size and transfer size (single or burst) are considered. This operation is repeated until the counter (CURR_TC) becomes 0 in Whole service mode, while performed only once in Single service mode. The main FSM (this FSM) counts down the CURR_TC when the sub-FSM finishes each of atomic operation. In addition, this main FSM asserts the INT REQ signal when CURR_TC becomes 0 and the interrupt setting of DCON[29] register is set to 1. In addition, it clears DMA ACK .if one of the following conditions is met.
 - 1) CURR_TC becomes 0 in the Whole service mode
 - 2) Atomic operation finishes in the Single service mode.

Note that in the Single service mode, these three states of main FSM are performed and then stops, and wait for another DMA REQ. And if DMA REQ comes in, all three states are repeated. Therefore, DMA ACK is asserted and then de-asserted for each atomic transfer. In contrast, in the Whole service mode, main FSM waits at state-3 until CURR_TC becomes 0. Therefore, DMA ACK is asserted during all the transfers and then de-asserted when TC reaches 0.

However, INT REQ is asserted only if CURR_TC becomes 0 regardless of the service mode (Single service mode or Whole service mode).

EXTERNAL DMA DREQ/DACK PROTOCOL

There are three types of external DMA request/acknowledge protocols (Single service Demand, Single service Handshake and Whole service Handshake mode). Each type defines how the signals like DMA request and acknowledge are related to these protocols.

Basic DMA Timing

The DMA service means performing paired Reads and Writes cycles during DMA operation, which can make one DMA operation. Figure 8-1 shows the basic Timing in the DMA operation of the S3C2440A.

- The setup time and the delay time of XnXDREQ and XnXDACK are the same in all the modes.
- If the completion of XnXDREQ meets its setup time, it is synchronized twice and then XnXDACK is asserted.
- After assertion of XnXDACK, DMA requests the bus and if it gets the bus it performs its operations. XnXDACK is de-asserted when DMA operation is completed.

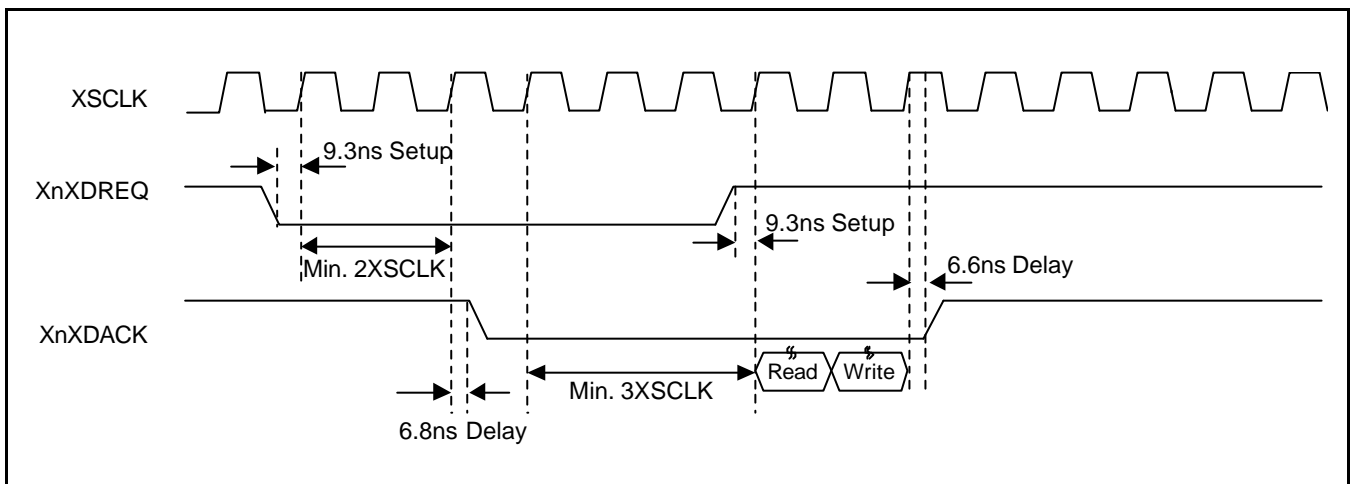

Figure 8-1. Basic DMA Timing Diagram

Demand/Handshake Mode Comparison

Demand and Handshake modes are related to the protocol between XnXDREQ and XnXDACK. Figure 8-2 shows the differences between the two modes.

At the end of one transfer (Single/Burst transfer), DMA checks the state of double-synched XnXDREQ.

Demand Mode

- If XnXDREQ remains asserted, the next transfer starts immediately. Otherwise it waits for XnXDREQ to be asserted.

Handshake Mode

- If XnXDREQ is de-asserted, DMA de-asserts XnXDACK in 2cycles. Otherwise it waits until XnXDREQ is de-asserted.

Caution: XnXDREQ has to be asserted (low) only after the de-assertion (high) of XnXDACK.

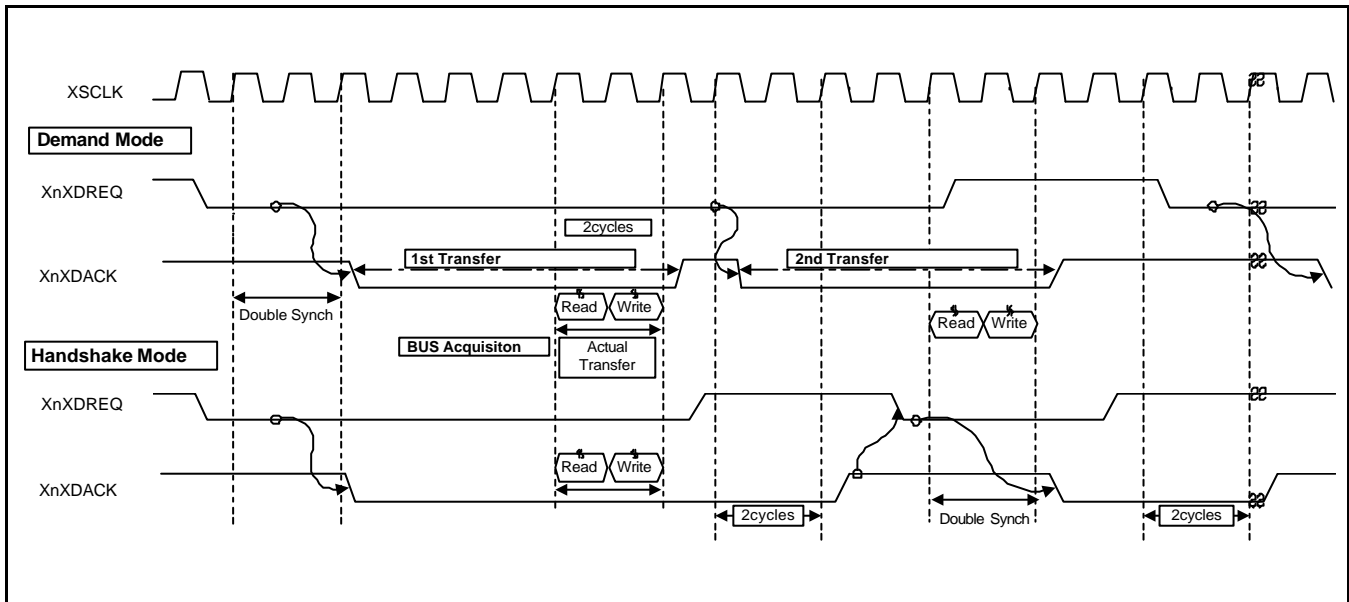

Figure 8-2. Demand/Handshake Mode Comparison

Transfer Size

- There are two different transfer sizes; unit and Burst 4.
- DMA holds the bus firmly during the transfer of the chunk of data. Thus, other bus masters cannot get the bus.

Burst 4 Transfer Size

There will be four sequential Reads and Writes performed in the Burst 4 Transfer respectively.

NOTE

Unit Transfer size: One read and one write is performed.

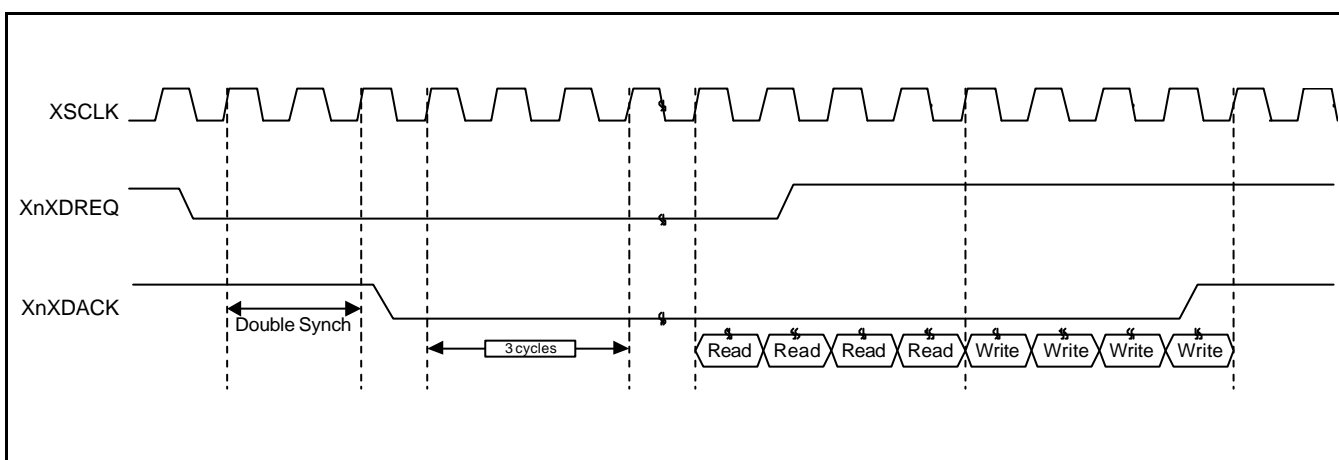

Figure 8-3. Burst 4 Transfer Size

EXAMPLES

Single service in Demand Mode with Unit Transfer Size

The assertion of XnXDREQ will be a need for every unit transfer (Single service mode). The operation continues while the XnXDREQ is asserted (Demand mode), and one pair of Read and Write (Single transfer size) is performed.

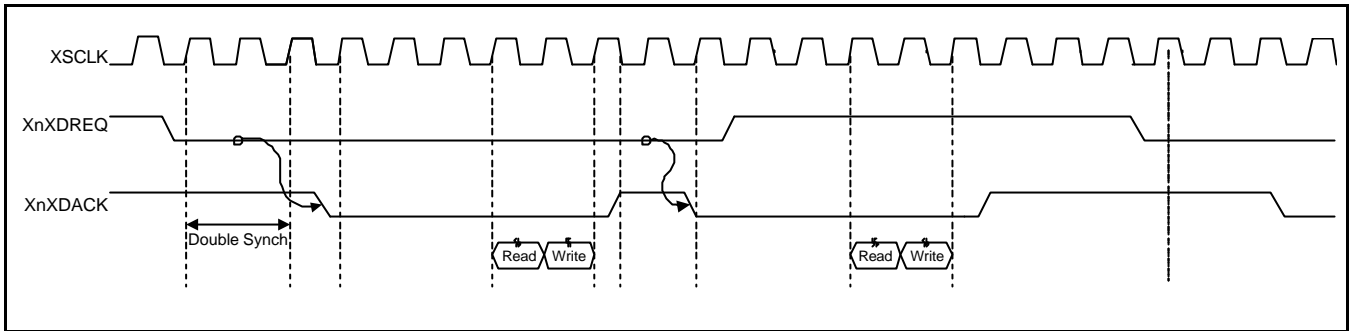

Figure 8-4. Single service in Demand Mode with Unit Transfer Size

Single service in Handshake Mode with Unit Transfer Size

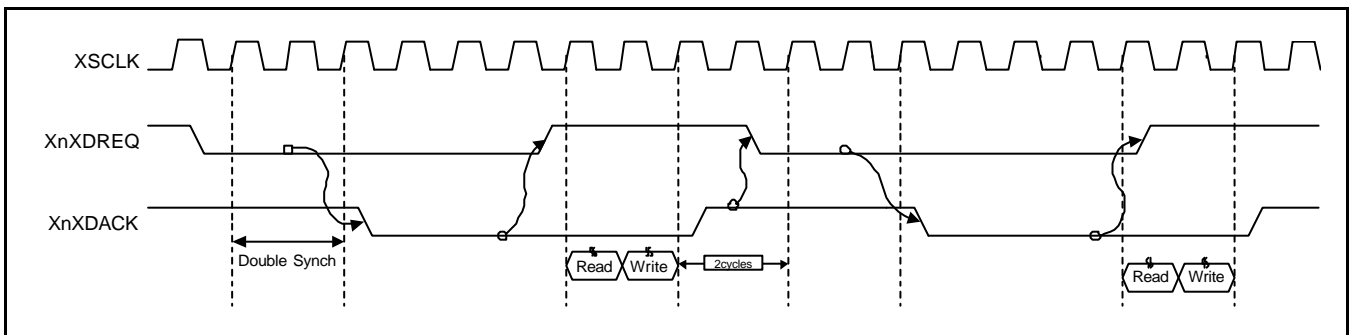

Figure 8-5. Single service in Handshake Mode with Unit Transfer Size

Whole service in Handshake Mode with Unit Transfer Size

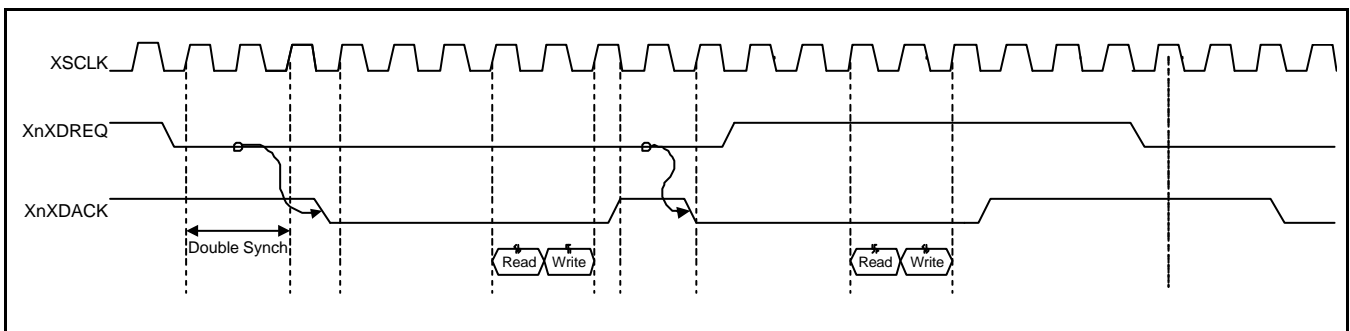

Figure 8-6. Whole service in Handshake Mode with Unit Transfer Size

DMA SPECIAL REGISTERS

Each DMA channel has nine control registers (36 in total since there are four channels for DMA controller). Six of the control registers control the DMA transfer, and other three ones monitor the status of DMA controller. The details of those registers are as follows.

DMA INITIAL SOURCE (DISRC) REGISTER

Register	Address	R/W	Description	Reset Value
DISRC0	0x4B000000	R/W	DMA 0 initial source register	0x00000000
DISRC1	0x4B000040	R/W	DMA 1 initial source register	0x00000000
DISRC2	0x4B000080	R/W	DMA 2 initial source register	0x00000000
DISRC3	0x4B0000C0	R/W	DMA 3 initial source register	0x00000000

DISRCn	Bit	Description	Initial State
S_ADDR	[30:0]	Base address (start address) of source data to transfer. This bit value will be loaded into CURR_SRC only if the CURR_SRC is 0 and the DMA ACK is 1.	0x00000000

DMA INITIAL SOURCE CONTROL (DISRCC) REGISTER

Register	Address	R/W	Description	Reset Value
DISRCC0	0x4B000004	R/W	DMA 0 initial source control register	0x00000000
DISRCC1	0x4B000044	R/W	DMA 1 initial source control register	0x00000000
DISRCC2	0x4B000084	R/W	DMA 2 initial source control register	0x00000000
DISRCC3	0x4B0000C4	R/W	DMA 3 initial source control register	0x00000000

DISRCCn	Bit	Description	Initial State
LOC	[1]	Bit 1 is used to select the location of source. 0: the source is in the system bus (AHB). 1: the source is in the peripheral bus (APB).	0
INC	[0]	Bit 0 is used to select the address increment. 0 = Increment 1 = Fixed If it is 0, the address is increased by its data size after each transfer in burst and single transfer mode. If it is 1, the address is not changed after the transfer. (In the burst mode, address is increased during the burst transfer, but the address is recovered to its first value after the transfer.)	0

DMA INITIAL DESTINATION (DIDST) REGISTER

Register	Address	R/W	Description	Reset Value
DIDST0	0x4B000008	R/W	DMA 0 initial destination register	0x00000000
DIDST1	0x4B000048	R/W	DMA 1 initial destination register	0x00000000
DIDST2	0x4B000088	R/W	DMA 2 initial destination register	0x00000000
DIDST3	0x4B0000B8	R/W	DMA 3 initial destination register	0x00000000

DIDSTn	Bit	Description	Initial State
D_ADDR	[30:0]	Base address (start address) of destination for the transfer. This bit value will be loaded into CURR_SRC only if the CURR_DST is 0 and the DMA ACK is 1.	0x00000000

DMA INITIAL DESTINATION CONTROL (DIDSTC) REGISTER

Register	Address	R/W	Description	Reset Value
DIDSTC0	0x4B00000C	R/W	DMA 0 initial destination control register	0x00000000
DIDSTC1	0x4B00004C	R/W	DMA 1 initial destination control register	0x00000000
DIDSTC2	0x4B00008C	R/W	DMA 2 initial destination control register	0x00000000
DIDSTC3	0x4B0000CC	R/W	DMA 3 initial destination control register	0x00000000

DIDSTCn	Bit	Description	Initial State
CHK_INT	[2]	Select interrupt occurrence time when auto reload is setting. 0: Interrupt will occur when TC reaches 0. 1: Interrupt will occur after auto-reload is performed.	0
LOC	[1]	Bit 1 is used to select the location of destination. 0: the destination is in the system bus (AHB). 1: the destination is in the peripheral bus (APB).	0
INC	[0]	Bit 0 is used to select the address increment. 0 = Increment 1 = Fixed If it is 0, the address is increased by its data size after each transfer in burst and single transfer mode. If it is 1, the address is not changed after the transfer. (In the burst mode, address is increased during the burst transfer, but the address is recovered to its first value after the transfer.)	0

DMA CONTROL (DCON) REGISTER

Register	Address	R/W	Description	Reset Value
DCON0	0x4B000010	R/W	DMA 0 control register	0x00000000
DCON1	0x4B000050	R/W	DMA 1 control register	0x00000000
DCON2	0x4B000090	R/W	DMA 2 control register	0x00000000
DCON3	0x4B0000D0	R/W	DMA 3 control register	0x00000000

DCONn	Bit	Description	Initial State
DMD_HS	[31]	<p>Select one between Demand mode and Handshake mode. 0: Demand mode will be selected. 1: Handshake mode will be selected.</p> <p>In both modes, DMA controller starts its transfer and asserts DACK for a given asserted DREQ. The difference between the two modes is whether it waits for the de-asserted DACK or not.</p> <p>In the Handshake mode, DMA controller waits for the de-asserted DREQ before starting a new transfer. If it finds the de-asserted DREQ, it de-asserts DACK and waits for another asserted DREQ.</p> <p>In contrast, in the Demand mode, DMA controller does not wait until the DREQ is de-asserted. It just de-asserts DACK and then starts another transfer if DREQ is asserted.</p> <p>We recommend using Handshake mode for external DMA request sources to prevent unintended starts of new transfers.</p>	0
SYNC	[30]	<p>Select DREQ/DACK synchronization. 0: DREQ and DACK are synchronized to PCLK (APB clock). 1: DREQ and DACK are synchronized to HCLK (AHB clock).</p> <p>Therefore, for devices attached to AHB system bus, this bit has to be set to 1, while for those attached to APB system, it should be set to 0. For the devices attached to external systems, the user should select this bit depending on which the external system is synchronized with between AHB system and APB system.</p>	0
INT	[29]	<p>Enable/Disable the interrupt setting for CURR_TC (terminal count) 0: CURR_TC interrupt is disabled. The user has to view the transfer count in the status register (i.e. polling). 1: Interrupt request is generated when all the transfer is done (i.e. CURR_TC becomes 0).</p>	0
TSZ	[28]	<p>Select the transfer size of an atomic transfer (i.e. transfer performed each time DMA owns the bus before releasing the bus). 0: A unit transfer is performed. 1: A burst transfer of length four is performed.</p>	0

DMA CONTROL (DCON) REGISTER (Continued)

DCONn	Bit	Description	Initial State
SERVMODE	[27]	Select the service mode between Single service mode and Whole service mode. 0: Single service mode is selected in which after each atomic transfer (single or burst of length four) DMA stops and waits for another DMA request. 1: Whole service mode is selected in which one request gets atomic transfers to be repeated until the transfer count reaches to 0. In this mode, additional request are not required. Note that even in the Whole service mode, DMA releases the bus after each atomic transfer and then tries to re-get the bus to prevent starving of other bus masters.	0
HWSRCSEL	[26:24]	Select DMA request source for each DMA. DCON0: 000:nXDREQ0 001:UART0 010:SDI 011:Timer 100:USB device EP1 DCON1: 000:nXDREQ1 001:UART1 010:I2SSDI 011:SPI 100:USB device EP2 DCON2: 000:I2SSDO 001:I2SSDI 010:SDI 011:Timer 100:USB device EP3 DCON3: 000:UART2 001:SDI 010:SPI 011:Timer 100:USB device EP4 DCON0: 101:I2SSDO 110:PCMIN DCON1: 101:PCMOUT 110:SDI DCON2: 101:PCMIN 110:MICIN DCON3: 101:MICIN 110:PCMOUT These bits control the 4-1 MUX to select the DMA request source of each DMA. These bits have meanings only if H/W request mode is selected by DCONn[23].	00
SWHW_SEL	[23]	Select the DMA source between software (S/W request mode) and hardware (H/W request mode). 0: S/W request mode is selected and DMA is triggered by setting SW_TRIG bit of DMASKTRIG control register. 1: DMA source selected by bit[26:24] triggers the DMA operation.	0
RELOAD	[22]	Set the reload on/off option. 0: auto reload is performed when a current value of transfer count becomes 0 (i.e. all the required transfers are performed). 1: DMA channel (DMA REQ) is turned off when a current value of transfer count becomes 0. The channel on/off bit (DMASKTRIGn[1]) is set to 0 (DREQ off) to prevent unintended further start of new DMA operation.	0

DMA CONTROL (DCON) REGISTER (Continued)

DCONn	Bit	Description	Initial State
DSZ	[21:20]	Data size to be transferred. 00 = Byte 01 = Half word 10 = Word 11 = reserved	00
TC	[19:0]	Initial transfer count (or transfer beat). Note that the actual number of bytes that are transferred is computed by the following equation: $DSZ \times TSZ \times TC$. Where, DSZ, TSZ (1 or 4), and TC represent data size DCONn[21:20], transfer size DCONn[28], and initial transfer count, respectively. This value will be loaded into CURR_TC only if the CURR_TC is 0 and the DMA ACK is 1.	00000

DMA STATUS (DSTAT) REGISTER

Register	Address	R/W	Description	Reset Value
DSTAT0	0x4B000014	R	DMA 0 count register	000000h
DSTAT1	0x4B000054	R	DMA 1 count register	000000h
DSTAT2	0x4B000094	R	DMA 2 count register	000000h
DSTAT3	0x4B0000D4	R	DMA 3 count register	000000h

DSTATn	Bit	Description	Initial State
STAT	[21:20]	Status of this DMA controller. 00: Indicates that DMA controller is ready for another DMA request. 01: Indicates that DMA controller is busy for transfers.	00b
CURR_TC	[19:0]	Current value of transfer count. Note that transfer count is initially set to the value of DCONn[19:0] register and decreased by one at the end of every atomic transfer.	00000h

DMA CURRENT SOURCE (DCSRC) REGISTER

Register	Address	R/W	Description	Reset Value
DCSRC0	0x4B000018	R	DMA 0 current source register	0x00000000
DCSRC1	0x4B000058	R	DMA 1 current source register	0x00000000
DCSRC2	0x4B000098	R	DMA 2 current source register	0x00000000
DCSRC3	0x4B0000D8	R	DMA 3 current source register	0x00000000

DCSRCn	Bit	Description	Initial State
CURR_SRC	[30:0]	Current source address for DMA _n	0x00000000

CURRENT DESTINATION (DCDST) REGISTER

Register	Address	R/W	Description	Reset Value
DCDST0	0x4B00001C	R	DMA 0 current destination register	0x00000000
DCDST1	0x4B00005C	R	DMA 1 current destination register	0x00000000
DCDST2	0x4B00009C	R	DMA 2 current destination register	0x00000000
DCDST3	0x4B0000DC	R	DMA 3 current destination register	0x00000000

DCDSTn	Bit	Description	Initial State
CURR_DST	[30:0]	Current destination address for DMA _n	0x00000000

DMA MASK TRIGGER (DMASKTRIG) REGISTER

Register	Address	R/W	Description	Reset Value
DMASKTRIG0	0x4B000020	R/W	DMA 0 mask trigger register	000
DMASKTRIG1	0x4B000060	R/W	DMA 1 mask trigger register	000
DMASKTRIG2	0x4B0000A0	R/W	DMA 2 mask trigger register	000
DMASKTRIG3	0x4B0000E0	R/W	DMA 3 mask trigger register	000

DMASKTRIGn	Bit	Description	Initial State
STOP	[2]	<p>Stop the DMA operation.</p> <p>1: DMA stops as soon as the current atomic transfer ends. If there is no current running atomic transfer, DMA stops immediately. The CURR_TC, CURR_SRC, and CURR_DST will be 0.</p> <p>Note: Due to possible current atomic transfer, "stop" operation may take several cycles. The finish of the operation (i.e. actual stop time) can be detected as soon as the channel on/off bit (DMASKTRIGn[1]) is set to off. This stop is "actual stop".</p>	0
ON_OFF	[1]	<p>DMA channel on/off bit.</p> <p>0: DMA channel is turned off. (DMA request to this channel is ignored.)</p> <p>1: DMA channel is turned on and the DMA request is handled. This bit is automatically set to off if we set the DCONn[22] bit to "no auto reload" and/or STOP bit of DMASKTRIGn to "stop". Note that when DCON[22] bit is "no auto reload", this bit becomes 0 when CURR_TC reaches 0. If the STOP bit is 1, this bit becomes 0 as soon as the current atomic transfer is completed.</p> <p>Note: This bit should not be changed manually during DMA operations (i.e. this has to be changed only by using DCON[22] or STOP bit).</p>	0
SW_TRIG	[0]	<p>Trigger the DMA channel in S/W request mode.</p> <p>1: it requests a DMA operation to this controller.</p> <p>Note that this trigger gets effective after S/W request mode has to be selected (DCONn[23]) and channel ON_OFF bit has to be set to 1 (channel on). When DMA operation starts, this bit is cleared automatically.</p>	0

NOTE: You are allowed to change the values of DISRC register, DIDST registers, and TC field of DCON register. Those changes take effect only after the finish of current transfer (i.e. when CURR_TC becomes 0). On the other hand, any change made to other registers and/or fields takes immediate effect. Therefore, be careful in changing those registers and fields.

9 I/O PORTS

OVERVIEW

S3C2440A has 130 multi-functional input/output port pins and there are eight ports as shown below:

- Port A(GPA): 25-output port
- Port B(GPB): 11-input/out port
- Port C(GPC): 16-input/output port
- Port D(GPD): 16-input/output port
- Port E(GPE): 16-input/output port
- Port F(GPF): 8-input/output port
- Port G(GPG): 16-input/output port
- Port H(GPH): 9-input/output port
- Port J(GPJ): 13-input/output port

Each port can be easily configured by software to meet various system configurations and design requirements. You have to define which function of each pin is used before starting the main program. If a pin is not used for multiplexed functions, the pin can be configured as I/O ports.

Initial pin states are configured seamlessly to avoid problems.

Table 9-1. S3C2440A Port Configuration (Sheet 1 of 5)

Port A	Selectable Pin Functions			
GPA22	Output only	nFCE	–	–
GPA21	Output only	nRSTOUT	–	–
GPA20	Output only	nFRE	–	–
GPA19	Output only	nFWE	–	–
GPA18	Output only	ALE	–	–
GPA17	Output only	CLE	–	–
GPA16	Output only	nGCS5	–	–
GPA15	Output only	nGCS4	–	–
GPA14	Output only	nGCS3	–	–
GPA13	Output only	nGCS2	–	–
GPA12	Output only	nGCS1	–	–
GPA11	Output only	ADDR26	–	–
GPA10	Output only	ADDR25	–	–
GPA9	Output only	ADDR24	–	–
GPA8	Output only	ADDR23	–	–
GPA7	Output only	ADDR22	–	–
GPA6	Output only	ADDR21	–	–
GPA5	Output only	ADDR20	–	–
GPA4	Output only	ADDR19	–	–
GPA3	Output only	ADDR18	–	–
GPA2	Output only	ADDR17	–	–
GPA1	Output only	ADDR16	–	–
GPA0	Output only	ADDR0	–	–

Table 9-1. S3C2440A Port Configuration (Sheet 2 of 5) (Continued)

Port B	Selectable Pin Functions			
GPB10	Input/output	nXDREQ0	–	–
GPB9	Input/output	nXDACK0	–	–
GPB8	Input/output	nXDREQ1	–	–
GPB7	Input/output	nXDACK1	–	–
GPB6	Input/output	nXBREQ	–	–
GPB5	Input/output	nXBACK	–	–
GPB4	Input/output	TCLK0	–	–
GPB3	Input/output	TOUT3	–	–
GPB2	Input/output	TOUT2	–	–
GPB1	Input/output	TOUT1	–	–
GPB0	Input/output	TOUT0	–	–

Port C	Selectable Pin Functions			
GPC15	Input/output	VD7	–	–
GPC14	Input/output	VD6	–	–
GPC13	Input/output	VD5	–	–
GPC12	Input/output	VD4	–	–
GPC11	Input/output	VD3	–	–
GPC10	Input/output	VD2	–	–
GPC9	Input/output	VD1	–	–
GPC8	Input/output	VD0	–	–
GPC7	Input/output	LCD_LPCREVB	–	–
GPC6	Input/output	LCD_LPCREV	–	–
GPC5	Input/output	LCD_LPCOE	–	–
GPC4	Input/output	VM	–	–
GPC3	Input/output	VFRAME	–	–
GPC2	Input/output	VLINE	–	–
GPC1	Input/output	VCLK	–	–
GPC0	Input/output	LEND	–	–

Table 9-1. S3C2440A Port Configuration (Sheet 3 of 5) (Continued)

Port D	Selectable Pin Functions			
GPD15	Input/output	VD23	nSS0	–
GPD14	Input/output	VD22	nSS1	–
GPD13	Input/output	VD21	–	–
GPD12	Input/output	VD20	–	–
GPD11	Input/output	VD19	–	–
GPD10	Input/output	VD18	SPICLK1	–
GPD9	Input/output	VD17	SPIMOSI1	–
GPD8	Input/output	VD16	SPIMISO1	–
GPD7	Input/output	VD15	–	–
GPD6	Input/output	VD14	–	–
GPD5	Input/output	VD13	–	–
GPD4	Input/output	VD12	–	–
GPD3	Input/output	VD11	–	–
GPD2	Input/output	VD10	–	–
GPD1	Input/output	VD9	–	–
GPD0	Input/output	VD8	–	–

Port E	Selectable Pin Functions			
GPE15	Input/output	IICSDA	–	–
GPE14	Input/output	IICSCSCL	–	–
GPE13	Input/output	SPICLK0	–	–
GPE12	Input/output	SPIMOSI0	–	–
GPE11	Input/output	SPIMISO0	–	–
GPE10	Input/output	SDDAT3	–	–
GPE9	Input/output	SDDAT2	–	–
GPE8	Input/output	SDDAT1	–	–
GPE7	Input/output	SDDAT0	–	–
GPE6	Input/output	SDCMD	–	–
GPE5	Input/output	SDCLK	–	–
GPE4	Input/output	I2SSDO	AC_SDATA_OUT	–
GPE3	Input/output	I2SSDI	AC_SDATA_IN	–
GPE2	Input/output	CDCLK	AC_nRESET	–
GPE1	Input/output	I2SSCLK	AC_BIT_CLK	–
GPE0	Input/output	I2SLRCK	AC_SYNC	–

Table 9-1. S3C2440A Port Configuration (Sheet 4 of 5) (Continued)

Port F	Selectable Pin Functions			
GPF7	Input/output	EINT7	–	–
GPF6	Input/output	EINT6	–	–
GPF5	Input/output	EINT5	–	–
GPF4	Input/output	EINT4	–	–
GPF3	Input/output	EINT3	–	–
GPF2	Input/output	EINT2		
GPF1	Input/output	EINT1		
GPF0	Input/output	EINT0		

Port G	Selectable Pin Functions			
GPG15	Input/output	EINT23	–	–
GPG14	Input/output	EINT22	–	–
GPG13	Input/output	EINT21	–	–
GPG12	Input/output	EINT20	–	–
GPG11	Input/output	EINT19	TCLK1	–
GPG10	Input/output	EINT18	nCTS1	–
GPG9	Input/output	EINT17	nRTS1	–
GPG8	Input/output	EINT16	–	–
GPG7	Input/output	EINT15	SPICLK1	–
GPG6	Input/output	EINT14	SPIMOSI1	–
GPG5	Input/output	EINT13	SPIMISO1	–
GPG4	Input/output	EINT12	LCD_PWREN	–
GPG3	Input/output	EINT11	nSS1	–
GPG2	Input/output	EINT10	nSS0	–
GPG1	Input/output	EINT9	–	–
GPG0	Input/output	EINT8	–	–

Table 9-1. S3C2440A Port Configuration (Sheet 5 of 5) (Continued)

Port H	Selectable Pin Functions			
GPH10	Input/output	CLKOUT1	–	–
GPH9	Input/output	CLKOUT0	–	–
GPH8	Input/output	UEXTCLK	–	–
GPH7	Input/output	RXD2	nCTS1	–
GPH6	Input/output	TXD2	nRTS1	–
GPH5	Input/output	RXD1	–	–
GPH4	Input/output	TXD1	–	–
GPH3	Input/output	RXD0	–	–
GPH2	Input/output	TXD0	–	–
GPH1	Input/output	nRTS0	–	–
GPH0	Input/output	nCTS0	–	–

Port J	Selectable Pin Functions			
GPJ12	Input/output	CAMRESET	–	–
GPJ11	Input/output	CAMCLKOUT	–	–
GPJ10	Input/output	CAMHREF	–	–
GPJ9	Input/output	CAMVSYNC	–	–
GPJ8	Input/output	CAMPCLK	–	–
GPJ7	Input/output	CAMDATA7	–	–
GPJ6	Input/output	CAMDATA6	–	–
GPJ5	Input/output	CAMDATA5	–	–
GPJ4	Input/output	CAMDATA4	–	–
GPJ3	Input/output	CAMDATA3	–	–
GPJ2	Input/output	CAMDATA2	–	–
GPJ1	Input/output	CAMDATA1	–	–
GPJ0	Input/output	CAMDATA0	–	–

PORT CONTROL DESCRIPTIONS

PORT CONFIGURATION REGISTER (GPAON-GPJON)

In S3C2440A, most of the pins are multiplexed pins. So, It is determined which function is selected for each pins. The PnCON(port control register) determines which function is used for each pin.

If PE0 – PE7 is used for the wakeup signal in power down mode, these ports must be configured in interrupt mode.

PORT DATA REGISTER (GPADAT-GPJDAT)

If Ports are configured as output ports, data can be written to the corresponding bit of PnDAT. If Ports are configured as input ports, the data can be read from the corresponding bit of PnDAT.

PORT PULL-UP REGISTER (GPBUP-GPJUP)

The port pull-up register controls the pull-up resistor enable/disable of each port group. When the corresponding bit is 0, the pull-up resistor of the pin is enabled. When 1, the pull-up resistor is disabled.

If the port pull-up register is enabled then the pull-up resistors work without pin's functional setting(input, output, DATAn, EINTn and etc)

MISCELLANEOUS CONTROL REGISTER

This register controls DATA port pull-up resistor in Sleep mode, USB pad, and CLKOUT selection.

EXTERNAL INTERRUPT CONTROL REGISTER

The 24 external interrupts are requested by various signaling methods. The EXTINT register configures the signaling method among the low level trigger, high level trigger, falling edge trigger, rising edge trigger, and both edge trigger for the external interrupt request

Because each external interrupt pin has a digital filter, the interrupt controller can recognize the request signal that is longer than 3 clocks.

EINT[15:0] are used for wakeup sources.

I/O PORT CONTROL REGISTER

PORT A CONTROL REGISTERS (GPACON, GPADAT)

Register	Address	R/W	Description	Reset Value
GPACON	0x56000000	R/W	Configures the pins of port A	0xfffff
GPADAT	0x56000004	R/W	The data register for port A	Undef.
Reserved	0x56000008	–	Reserved	Undef
Reserved	0x5600000c	–	Reserved	Undef

GPACON	Bit	Description	
GPA24	[24]	Reserved	
GPA23	[23]	Reserved	
GPA22	[22]	0 = Output	1 = nFCE
GPA21	[21]	0 = Output	1 = nRSTOUT
GPA20	[20]	0 = Output	1 = nFRE
GPA19	[19]	0 = Output	1 = nFWE
GPA18	[18]	0 = Output	1 = ALE
GPA17	[17]	0 = Output	1 = CLE
GPA16	[16]	0 = Output	1 = nGCS[5]
GPA15	[15]	0 = Output	1 = nGCS[4]
GPA14	[14]	0 = Output	1 = nGCS[3]
GPA13	[13]	0 = Output	1 = nGCS[2]
GPA12	[12]	0 = Output	1 = nGCS[1]
GPA11	[11]	0 = Output	1 = ADDR26
GPA10	[10]	0 = Output	1 = ADDR25
GPA9	[9]	0 = Output	1 = ADDR24
GPA8	[8]	0 = Output	1 = ADDR23
GPA7	[7]	0 = Output	1 = ADDR22
GPA6	[6]	0 = Output	1 = ADDR21
GPA5	[5]	0 = Output	1 = ADDR20
GPA4	[4]	0 = Output	1 = ADDR19
GPA3	[3]	0 = Output	1 = ADDR18
GPA2	[2]	0 = Output	1 = ADDR17
GPA1	[1]	0 = Output	1 = ADDR16
GPA0	[0]	0 = Output	1 = ADDR0

NOTE: The GPA21 signal level depends on VDDOP, the other pads (GPA0~20, GPA22~24) are all on VDDMOP.



PORT A CONTROL REGISTERS (GPACON, GPADAT) (Continued)

GPADAT	Bit	Description
GPA[24:0]	[24:0]	When the port is configured as output port, the pin state is the same as the corresponding bit. When the port is configured as functional pin, the undefined value will be read.

NOTE: nRSTOUT = nRESET & nWDTRST & SW_RESET

PORT B CONTROL REGISTERS (GPBCON, GPBDAT, GPBUP)

Register	Address	R/W	Description	Reset Value
GPBCON	0x56000010	R/W	Configures the pins of port B	0x0
GPBDAT	0x56000014	R/W	The data register for port B	Undef.
GPBUP	0x56000018	R/W	Pull-up disable register for port B	0x0
Reserved	0x5600001c			

PBCON	Bit	Description	
GPB10	[21:20]	00 = Input 10 = nXDREQ0	01 = Output 11 = reserved
GPB9	[19:18]	00 = Input 10 = nXDACK0	01 = Output 11 = reserved
GPB8	[17:16]	00 = Input 10 = nXDREQ1	01 = Output 11 = Reserved
GPB7	[15:14]	00 = Input 10 = nXDACK1	01 = Output 11 = Reserved
GPB6	[13:12]	00 = Input 10 = nXBREQ	01 = Output 11 = reserved
GPB5	[11:10]	00 = Input 10 = nXBACK	01 = Output 11 = reserved
GPB4	[9:8]	00 = Input 10 = TCLK [0]	01 = Output 11 = reserved
GPB3	[7:6]	00 = Input 10 = TOUT3	01 = Output 11 = reserved
GPB2	[5:4]	00 = Input 10 = TOUT2	01 = Output 11 = reserved]
GPB1	[3:2]	00 = Input 10 = TOUT1	01 = Output 11 = reserved
GPB0	[1:0]	00 = Input 10 = TOUT0	01 = Output 11 = reserved

GPBDAT	Bit	Description
GPB[10:0]	[10:0]	When the port is configured as input port, the corresponding bit is the pin state. When the port is configured as output port, the pin state is the same as the corresponding bit. When the port is configured as functional pin, the undefined value will be read.

GPBUP	Bit	Description
GPB[10:0]	[10:0]	0: The pull up function attached to the corresponding port pin is enabled. 1: The pull up function is disabled.

PORT C CONTROL REGISTERS (GPCCON, GPCDAT, GPCUP)

Register	Address	R/W	Description	Reset Value
GPCCON	0x56000020	R/W	Configures the pins of port C	0x0
GPCDAT	0x56000024	R/W	The data register for port C	Undef.
GPCUP	0x56000028	R/W	Pull-up disable register for port C	0x0
Reserved	0x5600002c	–	–	–

GPCCON	Bit	Description	
GPC15	[31:30]	00 = Input 10 = VD[7]	01 = Output 11 = Reserved
GPC14	[29:28]	00 = Input 10 = VD[6]	01 = Output 11 = Reserved
GPC13	[27:26]	00 = Input 10 = VD[5]	01 = Output 11 = Reserved
GPC12	[25:24]	00 = Input 10 = VD[4]	01 = Output 11 = Reserved
GPC11	[23:22]	00 = Input 10 = VD[3]	01 = Output 11 = Reserved
GPC10	[21:20]	00 = Input 10 = VD[2]	01 = Output 11 = Reserved
GPC9	[19:18]	00 = Input 10 = VD[1]	01 = Output 11 = Reserved
GPC8	[17:16]	00 = Input 10 = VD[0]	01 = Output 11 = Reserved
GPC7	[15:14]	00 = Input 10 = LCD_LPCREVB	01 = Output 11 = Reserved
GPC6	[13:12]	00 = Input 10 = LCD_LPCREV	01 = Output 11 = Reserved
GPC5	[11:10]	00 = Input 10 = LCD_LPCOE	01 = Output 11 = Reserved
GPC4	[9:8]	00 = Input 10 = VM	01 = Output 11 = I2SSDI
GPC3	[7:6]	00 = Input 10 = VFRAME	01 = Output 11 = Reserved
GPC2	[5:4]	00 = Input 10 = VLINE	01 = Output 11 = Reserved
GPC1	[3:2]	00 = Input 10 = VCLK	01 = Output 11 = Reserved
GPC0	[1:0]	00 = Input 10 = LEND	01 = Output 11 = Reserved

PORT C CONTROL REGISTERS (GPCCON, GPCDAT, GPCUP) (Continued)

GPCDAT	Bit	Description
GPC[15:0]	[15:0]	When the port is configured as input port, the corresponding bit is the pin state. When the port is configured as output port, the pin state is the same as the corresponding bit. When the port is configured as functional pin, the undefined value will be read.

GPCUP	Bit	Description
GPC[15:0]	[15:0]	0: The pull up function attached to the corresponding port pin is enabled. 1: The pull up function is disabled.

PORT D CONTROL REGISTERS (GPDCON, GPDDAT, GPDUP)

Register	Address	R/W	Description	Reset Value
GPDCON	0x56000030	R/W	Configures the pins of port D	0x0
GPDDAT	0x56000034	R/W	The data register for port D	Undef.
GPDUP	0x56000038	R/W	Pull-up disable register for port D	0xf000
Reserved	0x5600003c	–	–	–

GPDCON	Bit	Description	
GPD15	[31:30]	00 = Input 10 = VD[23]	01 = Output 11 = nSS0
GPD14	[29:28]	00 = Input 10 = VD[22]	01 = Output 11 = nSS1
GPD13	[27:26]	00 = Input 10 = VD[21]	01 = Output 11 = Reserved
GPD12	[25:24]	00 = Input 10 = VD[20]	01 = Output 11 = Reserved
GPD11	[23:22]	00 = Input 10 = VD[19]	01 = Output 11 = Reserved
GPD10	[21:20]	00 = Input 10 = VD[18]	01 = Output 11 = SPICLK1
GPD9	[19:18]	00 = Input 10 = VD[17]	01 = Output 11 = SPIMOS1
GPD8	[17:16]	00 = Input 10 = VD[16]	01 = Output 11 = SPIMISO1
GPD7	[15:14]	00 = Input 10 = VD[15]	01 = Output 11 = Reserved
GPD6	[13:12]	00 = Input 10 = VD[14]	01 = Output 11 = Reserved
GPD5	[11:10]	00 = Input 10 = VD[13]	01 = Output 11 = Reserved
GPD4	[9:8]	00 = Input 10 = VD[12]	01 = Output 11 = Reserved
GPD3	[7:6]	00 = Input 10 = VD[11]	01 = Output 11 = Reserved
GPD2	[5:4]	00 = Input 10 = VD[10]	01 = Output 11 = Reserved
GPD1	[3:2]	00 = Input 10 = VD[9]	01 = Output 11 = Reserved
GPD0	[1:0]	00 = Input 10 = VD[8]	01 = Output 11 = Reserved

PORT D CONTROL REGISTERS (GPDCON, GPDDAT, GPDUP) (Continued)

GPDDAT	Bit	Description
GPD[15:0]	[15:0]	When the port is configured as input port, the corresponding bit is the pin state. When the port is configured as output port, the pin state is the same as the corresponding bit. When the port is configured as functional pin, the undefined value will be read.

GPDUP	Bit	Description
GPD[15:0]	[15:0]	0: The pull up function attached to the corresponding port pin is enabled. 1: The pull up function is disabled.

PORT E CONTROL REGISTERS (GPECON, GPEDAT, GPEUP)

Register	Address	R/W	Description	Reset Value
GPECON	0x56000040	R/W	Configures the pins of port E	0x0
GPEDAT	0x56000044	R/W	The data register for port E	Undef.
GPEUP	0x56000048	R/W	Pull-up disable register for port E	0x0000
Reserved	0x5600004c	–	–	–

GPECON	Bit	Description	
GPE15	[31:30]	00 = Input 10 = IICSDA This pad is open-drain, There is no Pull-up option.	01 = Output 11 = Reserved
GPE14	[29:28]	00 = Input 10 = IICSCSCL This pad is open-drain, There is no Pull-up option.	01 = Output 11 = Reserved
GPE13	[27:26]	00 = Input 10 = SPICLK0	01 = Output 11 = Reserved
GPE12	[25:24]	00 = Input 10 = SPIMOSI0	01 = Output 11 = Reserved
GPE11	[23:22]	00 = Input 10 = SPIMISO0	01 = Output 11 = Reserved
GPE10	[21:20]	00 = Input 10 = SDDAT3	01 = Output 11 = Reserved
GPE9	[19:18]	00 = Input 10 = SDDAT2	01 = Output 11 = Reserved
GPE8	[17:16]	00 = Input 10 = SDDAT1	01 = Output 11 = Reserved
GPE7	[15:14]	00 = Input 10 = SDDAT0	01 = Output 11 = Reserved
GPE6	[13:12]	00 = Input 10 = SDCMD	01 = Output 11 = Reserved
GPE5	[11:10]	00 = Input 10 = SDCLK	01 = Output 11 = Reserved
GPE4	[9:8]	00 = Input 10 = I2SDO	01 = Output 11 = AC_SDATA_OUT
GPE3	[7:6]	00 = Input 10 = I2SDI	01 = Output 11 = AC_SDATA_IN
GPE2	[5:4]	00 = Input 10 = CDCLK	01 = Output 11 = AC_nRESET
GPE1	[3:2]	00 = Input 10 = I2SSCLK	01 = Output 11 = AC_BIT_CLK
GPE0	[1:0]	00 = Input 10 = I2SLRCK	01 = Output 11 = AC_SYNC

PORT E CONTROL REGISTERS (GPECON, GPEDAT, GPEUP) (Continued)

GPEDAT	Bit	Description
GPE[15:0]	[15:0]	When the port is configured as an input port, the corresponding bit is the pin state. When the port is configured as an output port, the pin state is the same as the corresponding bit. When the port is configured as a functional pin, the undefined value will be read.

GPEUP	Bit	Description
GPE[13:0]	[13:0]	0: The pull up function attached to the corresponding port pin is enabled. 1: The pull up function is disabled.

PORT F CONTROL REGISTERS (GPFCON, GPFDAT)

If GPF0–GPF7 will be used for wake-up signals at power down mode, the ports will be set in interrupt mode.

Register	Address	R/W	Description	Reset Value
GPFCON	0x56000050	R/W	Configures the pins of port F	0x0
GPFDAT	0x56000054	R/W	The data register for port F	Undef.
GPFUP	0x56000058	R/W	Pull-up disable register for port F	0x000
Reserved	0x5600005c	–	–	–

GPFCON	Bit	Description	
GPF7	[15:14]	00 = Input 10 = EINT[7]	01 = Output 11 = Reserved
GPF6	[13:12]	00 = Input 10 = EINT[6]	01 = Output 11 = Reserved
GPF5	[11:10]	00 = Input 10 = EINT[5]	01 = Output 11 = Reserved
GPF4	[9:8]	00 = Input 10 = EINT[4]	01 = Output 11 = Reserved
GPF3	[7:6]	00 = Input 10 = EINT[3]	01 = Output 11 = Reserved
GPF2	[5:4]	00 = Input 10 = EINT[2]	01 = Output 11 = Reserved
GPF1	[3:2]	00 = Input 10 = EINT[1]	01 = Output 11 = Reserved
GPF0	[1:0]	00 = Input 10 = EINT[0]	01 = Output 11 = Reserved

GPFDAT	Bit	Description
GPF[7:0]	[7:0]	When the port is configured as an input port, the corresponding bit is the pin state. When the port is configured as an output port, the pin state is the same as the corresponding bit. When the port is configured as functional pin, the undefined value will be read.

GPFUP	Bit	Description
GPF[7:0]	[7:0]	0: The pull up function attached to the corresponding port pin is enabled. 1: The pull up function is disabled.

PORT G CONTROL REGISTERS (GPGCON, GPGDAT)

If GPG0–GPG7 will be used for wake-up signals at Sleep mode, the ports will be set in interrupt mode.

Register	Address	R/W	Description	Reset Value
GPGCON	0x56000060	R/W	Configures the pins of port G	0x0
GPGDAT	0x56000064	R/W	The data register for port G	Undef.
GPGUP	0x56000068	R/W	Pull-up disable register for port G	0xfc00

GPGCON	Bit	Description	
GPG15*	[31:30]	00 = Input 10 = EINT[23]	01 = Output 11 = Reserved
GPG14*	[29:28]	00 = Input 10 = EINT[22]	01 = Output 11 = Reserved
GPG13*	[27:26]	00 = Input 10 = EINT[21]	01 = Output 11 = Reserved
GPG12	[25:24]	00 = Input 10 = EINT[20]	01 = Output 11 = Reserved
GPG11	[23:22]	00 = Input 10 = EINT[19]	01 = Output 11 = TCLK[1]
GPG10	[21:20]	00 = Input 10 = EINT[18]	01 = Output 11 = nCTS1
GPG9	[19:18]	00 = Input 10 = EINT[17]	01 = Output 11 = nRTS1
GPG8	[17:16]	00 = Input 10 = EINT[16]	01 = Output 11 = Reserved
GPG7	[15:14]	00 = Input 10 = EINT[15]	01 = Output 11 = SPICLK1
GPG6	[13:12]	00 = Input 10 = EINT[14]	01 = Output 11 = SPIMOS1
GPG5	[11:10]	00 = Input 10 = EINT[13]	01 = Output 11 = SPIMISO1
GPG4	[9:8]	00 = Input 10 = EINT[12]	01 = Output 11 = LCD_PWRDN
GPG3	[7:6]	00 = Input 10 = EINT[11]	01 = Output 11 = nSS1
GPG2	[5:4]	00 = Input 10 = EINT[10]	01 = Output 11 = nSS0
GPG1	[3:2]	00 = Input 10 = EINT[9]	01 = Output 11 = Reserved
GPG0	[1:0]	00 = Input 10 = EINT[8]	01 = Output 11 = Reserved

NOTE: GPG[15:13] must be selected as Input in NAND boot mode.

PORT G CONTROL REGISTERS (GPGCON, GPGDAT) (Continued)

GPGDAT	Bit	Description
GPG[15:0]	[15:0]	When the port is configured as an input port, the corresponding bit is the pin state. When the port is configured as an output port, the pin state is the same as the corresponding bit. When the port is configured as functional pin, the undefined value will be read.

GPGUP	Bit	Description
GPG[15:0]	[15:0]	0: The pull up function attached to the corresponding port pin is enabled. 1: The pull up function is disabled.

PORT H CONTROL REGISTERS (GPHCON, GPHDAT)

Register	Address	R/W	Description	Reset Value
GPHCON	0x56000070	R/W	Configures the pins of port H	0x0
GPHDAT	0x56000074	R/W	The data register for port H	Undef.
GPHUP	0x56000078	R/W	pull-up disable register for port H	0x000
Reserved	0x5600007c	–	–	–

GPHCON	Bit	Description	
GPH10	[21:20]	00 = Input 10 = CLKOUT1	01 = Output 11 = Reserved
GPH9	[19:18]	00 = Input 10 = CLKOUT0	01 = Output 11 = Reserved
GPH8	[17:16]	00 = Input 10 = UEXTCLK	01 = Output 11 = Reserved
GPH7	[15:14]	00 = Input 10 = RXD[2]	01 = Output 11 = nCTS1
GPH6	[13:12]	00 = Input 10 = TXD[2]	01 = Output 11 = nRTS1
GPH5	[11:10]	00 = Input 10 = RXD[1]	01 = Output 11 = Reserved
GPH4	[9:8]	00 = Input 10 = TXD[1]	01 = Output 11 = Reserved
GPH3	[7:6]	00 = Input 10 = RXD[0]	01 = Output 11 = reserved
GPH2	[5:4]	00 = Input 10 = TXD[0]	01 = Output 11 = Reserved
GPH1	[3:2]	00 = Input 10 = nRTS0	01 = Output 11 = Reserved
GPH0	[1:0]	00 = Input 10 = nCTS0	01 = Output 11 = Reserved

GPHDAT	Bit	Description
GPH[10:0]	[10:0]	When the port is configured as an input port, the corresponding bit is the pin state. When the port is configured as an output port, the pin state is the same as the corresponding bit. When the port is configured as functional pin, the undefined value will be read.

GPHUP	Bit	Description
GPH[10:0]	[10:0]	0: The pull up function attached to the corresponding port pin is enabled. 1: The pull up function is disabled.

PORT J CONTROL REGISTERS (GPJCON, GPJDAT)

Register	Address	R/W	Description	Reset Value
GPJCON	0x560000d0	R/W	Configures the pins of port J	0x0
GPJDAT	0x560000d4	R/W	The data register for port J	Undef.
GPJUP	0x560000d8	R/W	pull-up disable register for port J	0x0000
Reserved	0x560000dc	–	–	–

GPJCON	Bit	Description	
GPJ12	[25:24]	00 = Input 10 = CAMRESET	01 = Output 11 = Reserved
GPJ11	[23:22]	00 = Input 10 = CAMCLKOUT	01 = Output 11 = Reserved
GPJ10	[21:20]	00 = Input 10 = CAMHREF	01 = Output 11 = Reserved
GPJ9	[19:18]	00 = Input 10 = CAMVSYNC	01 = Output 11 = Reserved
GPJ8	[17:16]	00 = Input 10 = CAMPCLK	01 = Output 11 = Reserved
GPJ7	[15:14]	00 = Input 10 = CAMDATA[7]	01 = Output 11 = Reserved
GPJ6	[13:12]	00 = Input 10 = CAMDATA[6]	01 = Output 11 = Reserved
GPJ5	[11:10]	00 = Input 10 = CAMDATA[5]	01 = Output 11 = Reserved
GPJ4	[9:8]	00 = Input 10 = CAMDATA[4]	01 = Output 11 = Reserved
GPJ3	[7:6]	00 = Input 10 = CAMDATA[3]	01 = Output 11 = Reserved
GPJ2	[5:4]	00 = Input 10 = CAMDATA[2]	01 = Output 11 = Reserved
GPJ1	[3:2]	00 = Input 10 = CAMDATA[1]	01 = Output 11 = Reserved
GPJ0	[1:0]	00 = Input 10 = CAMDATA[0]	01 = Output 11 = Reserved

PORT J CONTROL REGISTERS (GPJCON, GPJDAT) (Continued)

GPJDAT	Bit	Description
GPJ15:0]	[12:0]	When the port is configured as an input port, the corresponding bit is the pin state. When the port is configured as an output port, the pin state is the same as the corresponding bit. When the port is configured as functional pin, the undefined value will be read.

GPJUP	Bit	Description
GPJ[12:0]	[12:0]	0: The pull up function attached to the corresponding port pin is enabled. 1: The pull up function is disabled.

MISCELLANEOUS CONTROL REGISTER (MISCCR)

In Sleep mode, the data bus(D[31:0] or D[15:0]) can be set as Hi-Z and Output '0' state. But, because of the characteristics of IO pad, the data bus pull-up resistors have to be turned on or off to reduce the power consumption. D[31:0] pin pull-up resistors can be controlled by MISCCR register.

Pads related USB are controlled by this register for USB host, or for USB device.

Register	Address	R/W	Description	Reset Value
MISCCR	0x56000080	R/W	Miscellaneous control register	0x10020

MISCCR	Bit	Description	Reset Value
Reserved	[24]	Reserve to 0.	0
Reserved	[23]	Reserve to 0.	0
BATT_FUNC	[22:20]	Battery fault function selection. 0XX: In nBATT_FLT=0, The system will be in reset status. After reset, Change this bit to other values, this bit is only for preventing from booting in Battery fault status. 10X: In sleep mode status, when nBATT_FLT=0, the system will wake-up. In normal mode, when nBATT_FLT=0, the Battery fault interrupt will occur. 110: In sleep mode status, during nBATT_FLT=0, the system will ignore all the wake-up events(the system will not wake-up by wake-up source). In normal mode, nBATT_FLT signal cannot affect the system. 111: nBATT_FLT function disable.	000
OFFREFRESH	[19]	0: Self refresh retain disable 1: Self refresh retain enable When 1, After wake-up from sleep, The self-refresh will be retained.	0
nEN_SCLK1	[18]	SCLK1 output enable 0: SCLK1 = SCLK 1: SCLK1 = 0	0
nEN_SCLK0	[17]	SCLK0 output enable 0: SCLK0 = SCLK 1: SCLK 0 = 0	0
nRSTCON	[16]	nRSTOUT signal manual control 0: nRSTOUT signal level will be low ('0') 1: nRSTOUT signal level will be high ('1')	1
Reserved	[15:14]	–	00
SEL_SUSPND1	[13]	USB Port 1 Suspend mode 0 = Normal mode 1 = Suspend mode	0
SEL_SUSPND0	[12]	USB Port 0 Suspend mode 0 = Normal mode 1 = Suspend mode	0

MISCELLANEOUS CONTROL REGISTER (MISCCR) (Continued)

MISCCR	Bit	Description	Reset Value
CLKSEL1 (Note)	[10:8]	Select source clock with CLKOUT1 pad 000 = MPLL output 001 = UPLL output 010 = RTC clock output 011 = HCLK 100 = PCLK 101 = DCLK1 11x = reserved	000
Reserved	[7]	–	0
CLKSEL0 (Note)	[6:4]	Select source clock with CLKOUT0 pad 000 = MPLL INPUT Clock(XTAL) 001 = UPLL output 010 = FCLK 011 = HCLK 100 = PCLK 101 = DCLK0 11x = reserved	010
SEL_USBPAD	[3]	USB1 Host/Device select register. 0 = Use USB1 as device 1 = Use USB1 as host	0
Reserved	[2]	Reserved	0
SPUCR1	[1]	0 = DATA[31:16] port pull-up resistor is enabled 1 = DATA[31:16] port pull-up resistor is disabled	0
SPUCR0	[0]	0 = DATA[15:0] port pull-up resistor is enabled 1 = DATA[15:0] port pull-up resistor is disabled	0

NOTE: We recommend not to use this output pad to other device's pll clock source.

DCLK CONTROL REGISTERS (DCLKCON)

Register	Address	R/W	Description	Reset Value
DCLKCON	0x56000084	R/W	DCLK0/1 control register	0x0

DCLKCON	Bit	Description
DCLK1CMP	[27:24]	DCLK1 compare value clock toggle value. ($< \text{DCLK1DIV}$) If the DCLK1CMP is n, Low level duration is(n + 1), High level duration is((DCLK1DIV + 1) – (n +1))
DCLK1DIV	[23:20]	DCLK1 divide value DCLK1 frequency = source clock / (DCLK1DIV + 1)
DCLK1SelCK	[17]	Select DCLK1 source clock 0 = PCLK 1 = UCLK(USB)
DCLK1EN	[16]	DCLK1 enable 0 = DCLK1 disable 1 = DCLK1 enable
DCLK0CMP	[11:8]	DCLK0 compare value clock toggle value.($< \text{DCLK0DIV}$) If the DCLK0CMP is n, Low level duration is(n + 1), High level duration is((DCLK0DIV + 1) – (n +1))
DCLK0DIV	[7:4]	DCLK0 divide value. DCLK0 frequency = source clock / (DCLK0DIV + 1)
DCLK0SelCK	[1]	Select DCLK0 source clock 0 = PCLK 1 = UCLK(USB)
DCLK0EN	[0]	DCLK0 enable 0 = DCLK0 disable 1 = DCLK0 enable

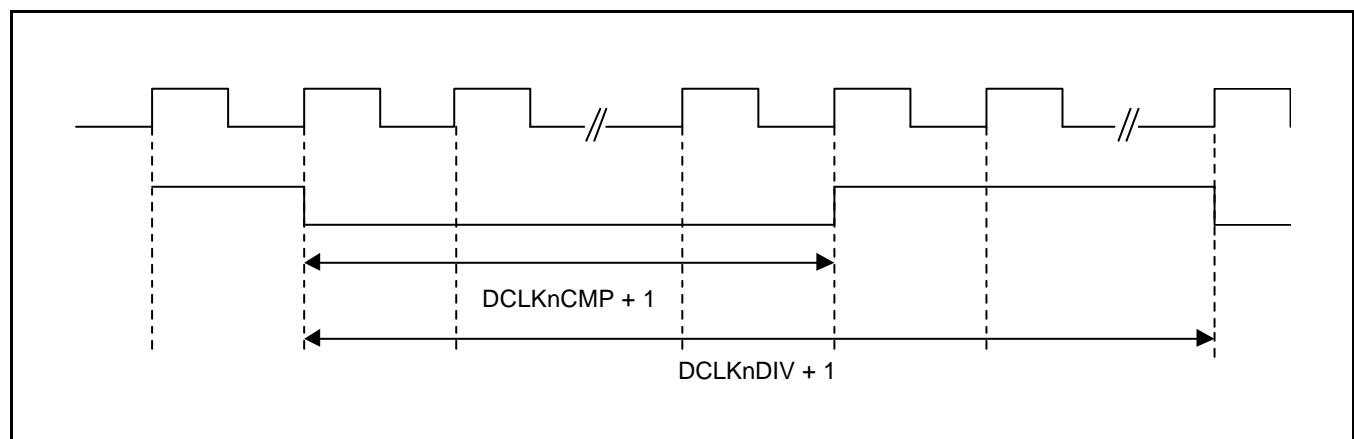

EXTINTn (External Interrupt Control Register n)

The 8 external interrupts can be requested by various signaling methods. The EXTINT register configures the signaling method between the level trigger and edge trigger for the external interrupt request, and also configures the signal polarity.

To recognize the level interrupt, the valid logic level on EXTINTn pin must be retained for 40ns at least because of the noise filter.

Register	Address	R/W	Description	Reset Value
EXTINT0	0x56000088	R/W	External interrupt control register 0	0x000000
EXTINT1	0x5600008c	R/W	External interrupt control register 1	0x000000
EXTINT2	0x56000090	R/W	External interrupt control register 2	0x000000

EXTINT0	Bit	Description
EINT7	[30:28]	Setting the signaling method of the EINT7. 000 = Low level 001 = High level 01x = Falling edge triggered 10x = Rising edge triggered 11x = Both edge triggered
EINT6	[26:24]	Setting the signaling method of the EINT6. 000 = Low level 001 = High level 01x = Falling edge triggered 10x = Rising edge triggered 11x = Both edge triggered
EINT5	[22:20]	Setting the signaling method of the EINT5. 000 = Low level 001 = High level 01x = Falling edge triggered 10x = Rising edge triggered 11x = Both edge triggered
EINT4	[18:16]	Setting the signaling method of the EINT4. 000 = Low level 001 = High level 01x = Falling edge triggered 10x = Rising edge triggered 11x = Both edge triggered
EINT3	[14:12]	Setting the signaling method of the EINT3. 000 = Low level 001 = High level 01x = Falling edge triggered 10x = Rising edge triggered 11x = Both edge triggered
EINT2	[10:8]	Setting the signaling method of the EINT2. 000 = Low level 001 = High level 01x = Falling edge triggered 10x = Rising edge triggered 11x = Both edge triggered
EINT1	[6:4]	Setting the signaling method of the EINT1. 000 = Low level 001 = High level 01x = Falling edge triggered 10x = Rising edge triggered 11x = Both edge triggered
EINT0	[2:0]	Setting the signaling method of the EINT0. 000 = Low level 001 = High level 01x = Falling edge triggered 10x = Rising edge triggered 11x = Both edge triggered

EXTINTn (External Interrupt Control Register n) (Continued)

EXTINT1	Bit	Description
FLTEN15	[31]	Filter enable for EINT15 0 = Filter Disable 1 = Filter Enable
EINT15	[30:28]	Setting the signaling method of the EINT15. 000 = Low level 001 = High level 01x = Falling edge triggered 10x = Rising edge triggered 11x = Both edge triggered
FLTEN14	[27]	Filter enable for EINT14 0 = Filter Disable 1 = Filter Enable
EINT14	[26:24]	Setting the signaling method of the EINT14. 000 = Low level 001 = High level 01x = Falling edge triggered 10x = Rising edge triggered 11x = Both edge triggered
FLTEN13	[23]	Filter enable for EINT13 0 = Filter Disable 1 = Filter Enable
EINT13	[22:20]	Setting the signaling method of the EINT13. 000 = Low level 001 = High level 01x = Falling edge triggered 10x = Rising edge triggered 11x = Both edge triggered
FLTEN12	[19]	Filter enable for EINT12 0 = Filter Disable 1 = Filter Enable
EINT12	[18:16]	Setting the signaling method of the EINT12. 000 = Low level 001 = High level 01x = Falling edge triggered 10x = Rising edge triggered 11x = Both edge triggered
FLTEN11	[15]	Filter enable for EINT11 0 = Filter Disable 1 = Filter Enable
EINT11	[14:12]	Setting the signaling method of the EINT11. 000 = Low level 001 = High level 01x = Falling edge triggered 10x = Rising edge triggered 11x = Both edge triggered
FLTEN10	[11]	Filter enable for EINT10 0 = Filter Disable 1 = Filter Enable
EINT10	[10:8]	Setting the signaling method of the EINT10. 000 = Low level 001 = High level 01x = Falling edge triggered 10x = Rising edge triggered 11x = Both edge triggered
FLTEN9	[7]	Filter enable for EINT9 0 = Filter Disable 1 = Filter Enable
EINT9	[6:4]	Setting the signaling method of the EINT9. 000 = Low level 001 = High level 01x = Falling edge triggered 10x = Rising edge triggered 11x = Both edge triggered
FLTEN8	[3]	Filter enable for EINT8 0 = Filter Disable 1 = Filter Enable
EINT8	[2:0]	Setting the signaling method of the EINT8. 000 = Low level 001 = High level 01x = Falling edge triggered 10x = Rising edge triggered 11x = Both edge triggered

EXTINTn (External Interrupt Control Register n) (Continued)

EXTINT2	Bit	Description	Reset Value
FLTEN23	[31]	Filter enable for EINT23 0 = Filter Disable 1= Filter Enable	0
EINT23	[30:28]	Setting the signaling method of the EINT23. 000 = Low level 001 = High level 01x = Falling edge triggered 10x = Rising edge triggered 11x = Both edge triggered	000
FLTEN22	[27]	Filter Enable for EINT22 0 = Filter Disable 1= Filter Enable	0
EINT22	[26:24]	Setting the signaling method of the EINT22. 000 = Low level 001 = High level 01x = Falling edge triggered 10x = Rising edge triggered 11x = Both edge triggered	000
FLTEN21	[23]	Filter Enable for EINT21 0 = Filter Disable 1= Filter Enable	0
EINT21	[22:20]	Setting the signaling method of the EINT21. 000 = Low level 001 = High level 01x = Falling edge triggered 10x = Rising edge triggered 11x = Both edge triggered	000
FLTEN20	[19]	Filter Enable for EINT20 0 = Filter Disable 1= Filter Enable	0
EINT20	[18:16]	Setting the signaling method of the EINT20. 000 = Low level 001 = High level 01x = Falling edge triggered 10x = Rising edge triggered 11x = Both edge triggered	000
FLTEN19	[15]	Filter enable for EINT19 0 = Filter Disable 1= Filter Enable	0
EINT19	[14:12]	Setting the signaling method of the EINT19. 000 = Low level 001 = High level 01x = Falling edge triggered 10x = Rising edge triggered 11x = Both edge triggered	000
FLTEN18	[11]	Filter enable for EINT18 0 = Filter Disable 1= Filter Enable	0
EINT18	[10:8]	Setting the signaling method of the EINT18. 000 = Low level 001 = High level 01x = Falling edge triggered 10x = Rising edge triggered 11x = Both edge triggered	000

EXTINTn (External Interrupt Control Register n) (Continued)

EXTINT2	Bit	Description	Reset Value
FLTEN17	[7]	Filter enable for EINT17 0 = Filter Disable 1= Filter Enable	0
EINT17	[6:4]	Setting the signaling method of the EINT17. 000 = Low level 001 = High level 01x = Falling edge triggered 10x = Rising edge triggered 11x = Both edge triggered	000
FLTEN16	[3]	Filter enable for EINT16 0 = Filter Disable 1= Filter Enable	0
EINT16	[2:0]	Setting the signaling method of the EINT16. 000 = Low level 001 = High level 01x = Falling edge triggered 10x = Rising edge triggered 11x = Both edge triggered	000

EINTFLTn (External Interrupt Filter Register n)

To recognize the level interrupt, the valid logic level on EXTINTn pin must be retained for 40ns at least because of the noise filter.

Register	Address	R/W	Description	Reset Value
EINTFLT0	0x56000094	R/W	Reserved	0x000000
EINTFLT1	0x56000098	R/W	Reserved	0x000000
EINTFLT2	0x5600009c	R/W	External interrupt control register 2	0x000000
EINTFLT3	0x4c6000a0	R/W	External interrupt control register 3	0x000000

EINTFLT2	Bit	Description
EINTFLT19	[30:24]	Filtering width of EINT19
FLTCLK18	[23]	Filter clock of EINT18 (configured by OM) 0 = PCLK 1 = EXTCLK/OSC_CLK
EINTFLT18	[22:16]	Filtering width of EINT18
FLTCLK17	[15]	Filter clock of EINT17 (configured by OM) 0 = PCLK 1 = EXTCLK/OSC_CLK
EINTFLT17	[14:8]	Filtering width of EINT17
FLTCLK16	[7]	Filter clock of EINT16 (configured by OM) 0 = PCLK 1 = EXTCLK/OSC_CLK
EINTFLT16	[6:0]	Filtering width of EINT16

EINTFLT3	Bit	Description
FLTCLK23	[31]	Filter clock of EINT23 (configured by OM) 0 = PCLK 1 = EXTCLK/OSC_CLK
EINTFLT23	[30:24]	Filtering width of EINT23
FLTCLK22	[23]	Filter clock of EINT22 (configured by OM) 0 = PCLK 1 = EXTCLK/OSC_CLK
EINTFLT22	[22:16]	Filtering width of EINT22
FLTCLK21	[15]	Filter clock of EINT21 (configured by OM) 0 = PCLK 1 = EXTCLK/OSC_CLK
EINTFLT21	[14:8]	Filtering width of EINT21
FLTCLK20	[7]	Filter clock of EINT20 (configured by OM) 0 = PCLK 1 = EXTCLK/OSC_CLK
EINTFLT20	[6:0]	Filtering width of EINT20

EINTMASK (External Interrupt Mask Register)

Register	Address	R/W	Description	Reset Value
EINTMASK	0x560000a4	R/W	External interrupt mask register	0x000fffff

EINTMASK	Bit	Description
EINT23	[23]	0 = enable interrupt 1= masked
EINT22	[22]	0 = enable interrupt 1= masked
EINT21	[21]	0 = enable interrupt 1= masked
EINT20	[20]	0 = enable interrupt 1= masked
EINT19	[19]	0 = enable interrupt 1= masked
EINT18	[18]	0 = enable interrupt 1= masked
EINT17	[17]	0 = enable interrupt 1= masked
EINT16	[16]	0 = enable interrupt 1= masked
EINT15	[15]	0 = enable interrupt 1= masked
EINT14	[14]	0 = enable interrupt 1= masked
EINT13	[13]	0 = enable interrupt 1= masked
EINT12	[12]	0 = enable interrupt 1= masked
EINT11	[11]	0 = enable interrupt 1= masked
EINT10	[10]	0 = enable interrupt 1= masked
EINT9	[9]	0 = enable interrupt 1= masked
EINT8	[8]	0 = enable interrupt 1= masked
EINT7	[7]	0 = enable interrupt 1= masked
EINT6	[6]	0 = enable interrupt 1= masked
EINT5	[5]	0 = enable interrupt 1= masked
EINT4	[4]	0 = enable interrupt 1= masked
Reserved	[3:0]	Reserved

EINTPEND (External Interrupt Pending Register)

Register	Address	R/W	Description	Reset Value
EINTPEND	0x560000a8	R/W	External interrupt pending register	0x00

EINTPEND	Bit	Description	Reset Value
EINT23	[23]	It is cleared by writing "1" 0 = Not occur 1 = Occur interrupt	0
EINT22	[22]	It is cleared by writing "1" 0 = Not occur 1 = Occur interrupt	0
EINT21	[21]	It is cleared by writing "1" 0 = Not occur 1 = Occur interrupt	0
EINT20	[20]	It is cleared by writing "1" 0 = Not occur 1 = Occur interrupt	0
EINT19	[19]	It is cleared by writing "1" 0 = Not occur 1 = Occur interrupt	0
EINT18	[18]	It is cleared by writing "1" 0 = Not occur 1 = Occur interrupt	0
EINT17	[17]	It is cleared by writing "1" 0 = Not occur 1 = Occur interrupt	0
EINT16	[16]	It is cleared by writing "1" 0 = Not occur 1 = Occur interrupt	0
EINT15	[15]	It is cleared by writing "1" 0 = Not occur 1 = Occur interrupt	0
EINT14	[14]	It is cleared by writing "1" 0 = Not occur 1 = Occur interrupt	0
EINT13	[13]	It is cleared by writing "1" 0 = Not occur 1 = Occur interrupt	0
EINT12	[12]	It is cleared by writing "1" 0 = Not occur 1 = Occur interrupt	0
EINT11	[11]	It is cleared by writing "1" 0 = Not occur 1 = Occur interrupt	0
EINT10	[10]	It is cleared by writing "1" 0 = Not occur 1 = Occur interrupt	0
EINT9	[9]	It is cleared by writing "1" 0 = Not occur 1 = Occur interrupt	0
EINT8	[8]	It is cleared by writing "1" 0 = Not occur 1 = Occur interrupt	0
EINT7	[7]	It is cleared by writing "1" 0 = Not occur 1 = Occur interrupt	0
EINT6	[6]	It is cleared by writing "1" 0 = Not occur 1 = Occur interrupt	0
EINT5	[5]	It is cleared by writing "1" 0 = Not occur 1 = Occur interrupt	0
EINT4	[4]	It is cleared by writing "1" 0 = Not occur 1 = Occur interrupt	0
Reserved	[3:0]	Reserved	0000

GSTATUSn (General Status Registers)

Register	Address	R/W	Description	Reset Value
GSTATUS0	0x560000ac	R	External pin status	Not define
GSTATUS1	0x560000b0	R	Chip ID	0x32440001
GSTATUS2	0x560000b4	R/W	Reset status	0x1
GSTATUS3	0x560000b8	R/W	Inform register	0x0
GSTATUS4	0x560000bc	R/W	Inform register	0x0

GSTATUS0	Bit	Description
nWAIT	[3]	Status of nWAIT pin
NCON	[2]	Status of NCON pin
RnB	[1]	Status of RnB pin
BATT_FLT	[0]	Status of BATT_FLT pin

GSTATUS1	Bit	Description
CHIP ID	[0]	ID register = 0x32440001

GSTATUS2	Bit	Description
Reserved	[3]	Reserved
WDTRST	[2]	Boot is caused by Watch Dog Reset cleared by writing "1"
SLEEP_RST	[1]	Boot is caused by wakeup reset in sleep mode cleared by writing "1".
PWRST	[0]	Boot is caused by power on reset cleared by writing "1"

GSTATUS3	Bit	Description
inform	[31:0]	Inform register. This register is cleared by power on reset. Otherwise, preserve data value.

GSTATUS4	Bit	Description
inform	[31:0]	Inform register. This register is cleared by power on reset. Otherwise, preserve data value.

DSCn (Drive Strength Control)

Control the Memory I/O drive strength

Register	Address	R/W	Description	Reset Value
DSC0	0x560000c4	R/W	Strength control register 0	0x0
DSC1	0x560000c8	R/W	Strength control register 1	0x0

DSC0	Bit	Description	Reset Value
nEN_DSC	[31]	Enable Drive Strength Control 0: enable 1: Disable	0
Reserved	[30:10]	–	0
DSC_ADR	[9:8]	Address Bus Drive strength. 00: 12mA 10: 10mA 01: 8mA 11: 6mA	00
DSC_DATA3	[7:6]	DATA[31:24] I/O Drive strength. 00: 12mA 10: 10mA 01: 8mA 11: 6mA	00
DSC_DATA2	[5:4]	DATA[23:16] I/O Drive strength. 00: 12mA 10: 10mA 01: 8mA 11: 6mA	00
DSC_DATA1	[3:2]	DATA[15:8] I/O Drive strength. 00: 12mA 10: 10mA 01: 8mA 11: 6mA	00
DSC_DATA0	[1:0]	DATA[7:0] I/O Drive strength. 00: 12mA 10: 10mA 01: 8mA 11: 6mA	00

DSCn (Drive Strength Control)

DSC1	Bit	Description	Reset Value
DSC_SCK1	[29:28]	SCLK1 drive strength. 00: 12mA 10: 10mA 01: 8mA 11: 6mA	00
DSC_SCK0	[27:26]	SCLK0 drive strength. 00: 12mA 10: 10mA 01: 8mA 11: 6mA	00
DSC_SCKE	[25:24]	SCKE drive strength. 00: 10mA 10: 8mA 01: 6mA 11: 4mA	00
DSC_SDR	[23:22]	nSRAS/nSCAS Drive strength. 00: 10mA 10: 8mA 01: 6mA 11: 4mA	00
DSC_NFC	[21:20]	Nand flash control drive strength (nFCE, nFRE, nFWE, CLE, ALE). 00: 10mA 10: 8mA 01: 6mA 11: 4mA	00
DSC_BE	[19:18]	nBE[3:0] drive strength. 00: 10mA 10: 8mA 01: 6mA 11: 4mA	00
DSC_WOE	[17:16]	nWE/nOE drive strength. 00: 10mA 10: 8mA 01: 6mA 11: 4mA	00
DSC_CS7	[15:14]	nGCS7 drive strength. 00: 10mA 10: 8mA 01: 6mA 11: 4mA	00
DSC_CS6	[13:12]	nGCS6 drive strength. 00: 10mA 10: 8mA 01: 6mA 11: 4mA	00
DSC_CS5	[11:10]	nGCS5 drive strength. 00: 10mA 10: 8mA 01: 6mA 11: 4mA	00
DSC_CS4	[9:8]	nGCS4 drive strength. 00: 10mA 10: 8mA 01: 6mA 11: 4mA	00
DSC_CS3	[7:6]	nGCS3 drive strength. 00: 10mA 10: 8mA 01: 6mA 11: 4mA	00
DSC_CS2	[5:4]	nGCS2 drive strength. 00: 10mA 10: 8mA 01: 6mA 11: 4mA	00
DSC_CS1	[3:2]	nGCS1 drive strength. 00: 10mA 10: 8mA 01: 6mA 11: 4mA	00
DSC_CS0	[1:0]	nGCS0 drive strength. 00: 10mA 10: 8mA 01: 6mA 11: 4mA	00

MSLCON (Memory Sleep Control Register)

Select memory interface status when in SLEEP mode.

Register	Address	R/W	Description	Reset Value
MSLCON	0x560000cc	R/W	Memory sleep control register	0x0

MSLCON	Bit	Description	Reset Value
PSC_DATA	[11]	DATA[31:0] pin status in sleep mode. 0: Hi-Z 1: Output "0".	0
PSC_WAIT	[10]	nWAIT pin status in sleep mode. 0: Input 1: Output "0"	0
PSC_RnB	[9]	RnB pin status in sleep mode. 0: Input 1: Output "0"	0
PSC_NF	[8]	NAND Flash I/F pin status in sleep mode(nFCE,nFRE,nFWE,ALE,CLE). 0: Inactive(nFCE,nFRE,nFWE,ALE,CLE = 11100) 1: Hi-Z	0
PSC_SDR	[7]	nSRAS, nSCAS pin status in sleep mode. 0: Inactive("1") 1: Hi-Z	0
PSC_DQM	[6]	DQM[3:0]/nWE[3:0] pin status in sleep mode. 0: Inactive 1: Hi-Z	0
PSC_OE	[5]	nOE pin status in sleep mode. 0: Inactive("1") 1: Hi-Z	0
PSC_WE	[4]	nWE pin status in sleep mode. 0: Inactive("1") 1: Hi-Z	0
PSC_GCS0	[3]	nGCS[0] pin status in sleep mode. 0: Inactive("1") 1: Hi-Z	0
PSC_GCS51	[2]	nGCS[5:1] pin status in sleep mode. 0: Inactive("1") 1: Hi-Z	0
PSC_GCS6	[1]	nGCS[6] pin status in sleep mode. 0: Inactive("1") 1: Hi-Z	0
PSC_GCS7	[0]	nGCS[7] pin status in sleep mode. 0: Inactive("1") 1: Hi-Z	0

10 PWM TIMER

OVERVIEW

The S3C2440A has five 16-bit timers. Timer 0, 1, 2, and 3 have Pulse Width Modulation (PWM) function. Timer 4 has an internal timer only with no output pins. The timer 0 has a dead-zone generator, which is used with a large current device.

The timer 0 and 1 share an 8-bit prescaler, while the timer 2, 3 and 4 share other 8-bit prescaler. Each timer has a clock divider, which generates 5 different divided signals (1/2, 1/4, 1/8, 1/16, and TCLK). Each timer block receives its own clock signals from the clock divider, which receives the clock from the corresponding 8-bit prescaler. The 8-bit prescaler is programmable and divides the PCLK according to the loading value, which is stored in TCFG0 and TCFG1 registers.

The timer count buffer register (TCNTBn) has an initial value which is loaded into the down-counter when the timer is enabled. The timer compare buffer register (TCMPBn) has an initial value which is loaded into the compare register to be compared with the down-counter value. This double buffering feature of TCNTBn and TCMPBn makes the timer generate a stable output when the frequency and duty ratio are changed.

Each timer has its own 16-bit down counter, which is driven by the timer clock. When the down counter reaches zero, the timer interrupt request is generated to inform the CPU that the timer operation has been completed. When the timer counter reaches zero, the value of corresponding TCNTBn is automatically loaded into the down counter to continue the next operation. However, if the timer stops, for example, by clearing the timer enable bit of TCONn during the timer running mode, the value of TCNTBn will not be reloaded into the counter.

The value of TCMPBn is used for pulse width modulation (PWM). The timer control logic changes the output level when the down-counter value matches the value of the compare register in the timer control logic. Therefore, the compare register determines the turn-on time (or turn-off time) of a PWM output.

FEATURE

- Five 16-bit timers
- Two 8-bit prescalers & Two 4-bit divider
- Programmable duty control of output waveform (PWM)
- Auto reload mode or one-shot pulse mode
- Dead-zone generator

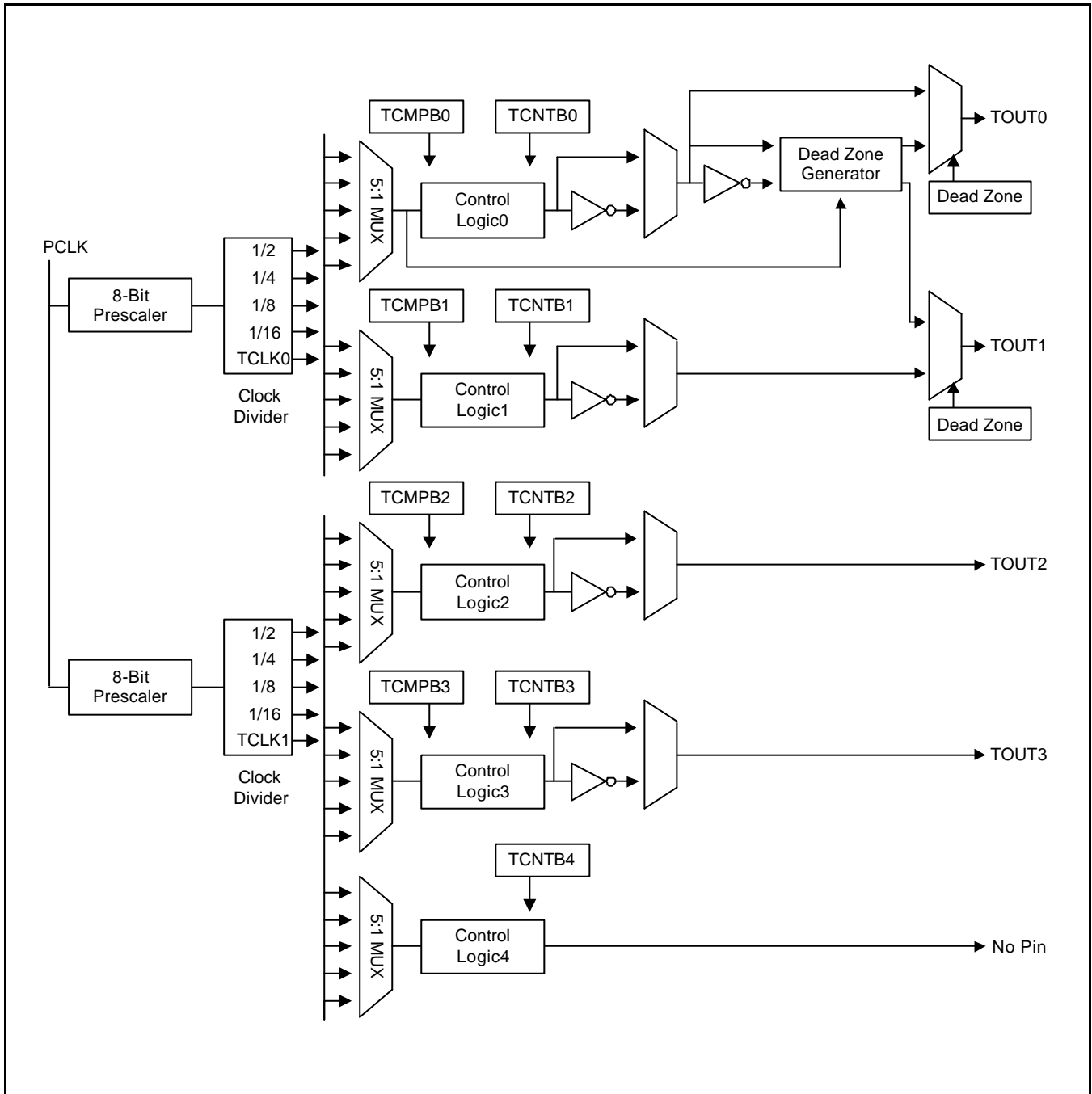

Figure 10-1. 16-bit PWM Timer Block Diagram

PWM TIMER OPERATION

PRESCALER & DIVIDER

An 8-bit prescaler and a 4-bit divider make the following output frequencies:

4-bit Divider Settings	Minimum Resolution (prescaler = 0)	Maximum Resolution (prescaler = 255)	Maximum Interval (TCNTBn = 65535)
1/2 (PCLK = 50 MHz)	0.0400 us (25.0000 MHz)	10.2400 us (97.6562 kHz)	0.6710 sec
1/4 (PCLK = 50 MHz)	0.0800 us (12.5000 MHz)	20.4800 us (48.8281 kHz)	1.3421 sec
1/8 (PCLK = 50 MHz)	0.1600 us (6.2500 MHz)	40.9601 us (24.4140 kHz)	2.6843 sec
1/16 (PCLK = 50 MHz)	0.3200 us (3.1250 MHz)	81.9188 us (12.2070 kHz)	5.3686 sec

BASIC TIMER OPERATION

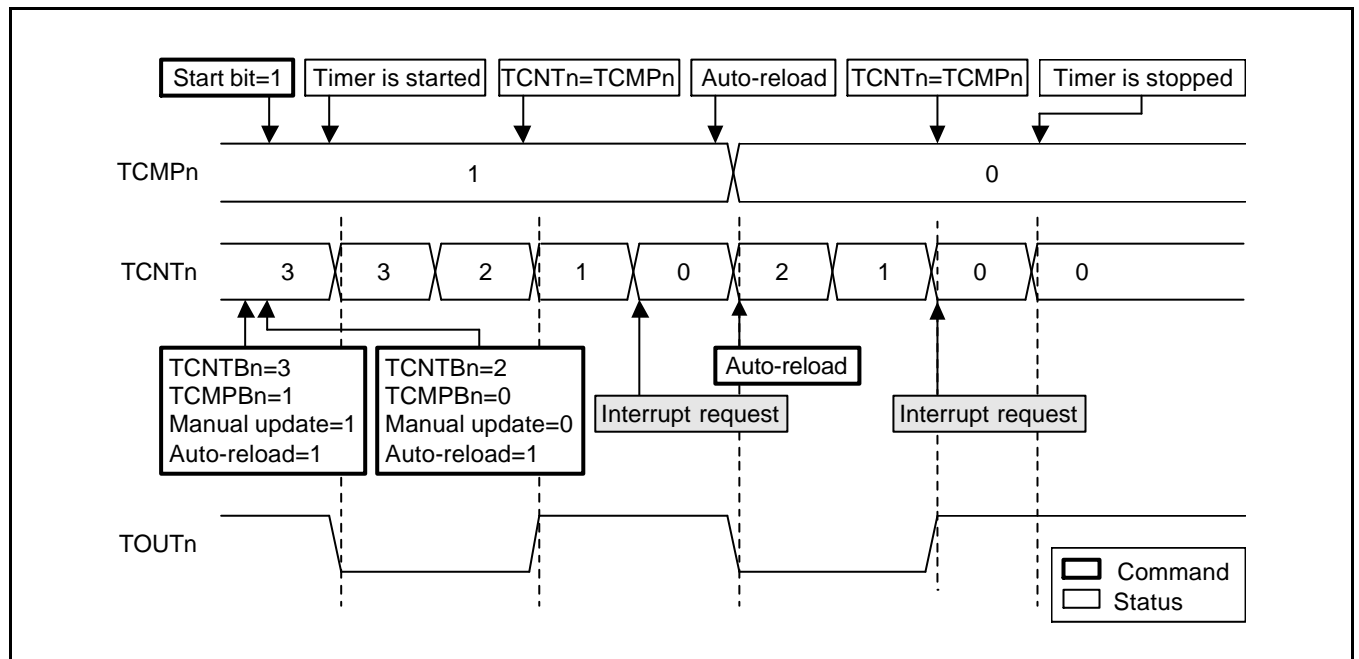

Figure 10-2. Timer Operations

A timer (except the timer ch-5) has TCNTBn, TCNTn, TCMPBn and TCMPn. (TCNTn and TCMPn are the names of the internal registers. The TCNTn register can be read from the TCNTOn register) The TCNTBn and the TCMPBn are loaded into the TCNTn and the TCMPn when the timer reaches 0. When the TCNTn reaches 0, an interrupt request will occur if the interrupt is enabled.

AUTO RELOAD & DOUBLE BUFFERING

S3C2440A PWM Timers have a double buffering function, enabling the reload value changed for the next timer operation without stopping the current timer operation. So, although the new timer value is set, a current timer operation is completed successfully.

The timer value can be written into Timer Count Buffer register (TCNTBn) and the current counter value of the timer can be read from Timer Count Observation register (TCNTOn). If the TCNTBn is read, the read value does not indicate the current state of the counter but the reload value for the next timer duration.

The auto-reload operation copies the TCNTBn into TCNTn when the TCNTn reaches 0. The value, written into the TCNTBn, is loaded to the TCNTn only when the TCNTn reaches 0 and auto reload is enabled. If the TCNTn becomes 0 and the auto reload bit is 0, the TCNTn does not operate any further.

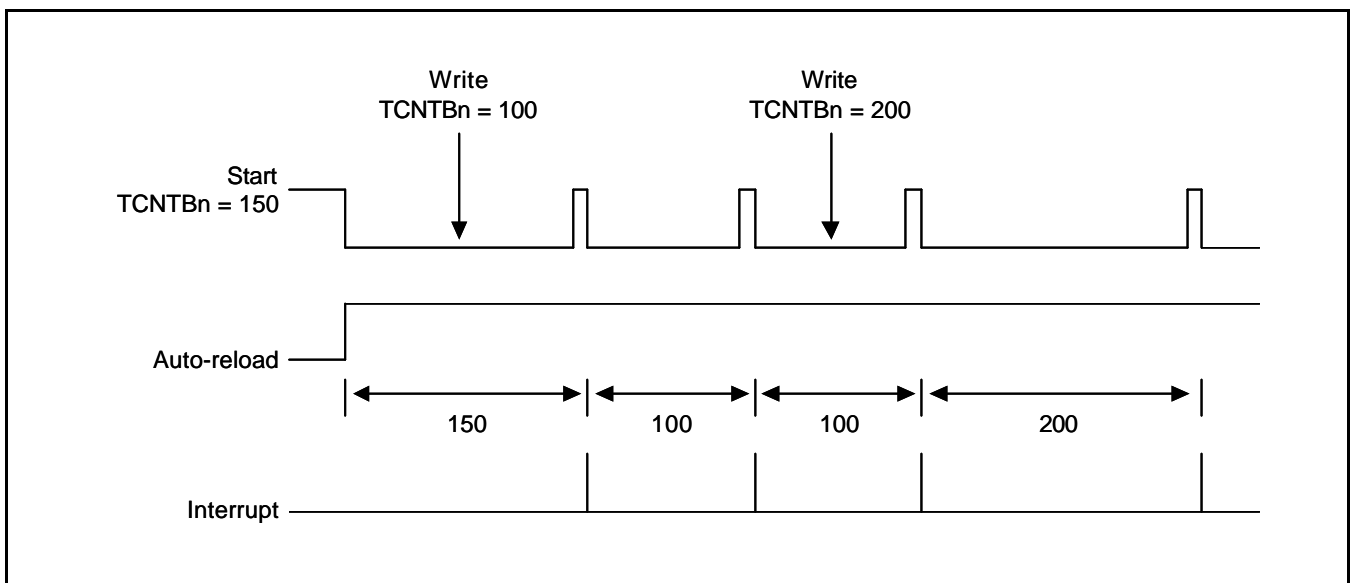

Figure 10-3. Example of Double Buffering Function

TIMER INITIALIZATION USING MANUAL UPDATE BIT AND INVERTER BIT

An auto reload operation of the timer occurs when the down counter reaches 0. So, a starting value of the TCNTn has to be defined by the user in advance. In this case, the starting value has to be loaded by the manual update bit. The following steps describe how to start a timer:

- 1) Write the initial value into TCNTBn and TCMPBn.
- 2) Set the manual update bit of the corresponding timer. It is recommended that you configure the inverter on/off bit. (Whether use inverter or not).
- 3) Set start bit of the corresponding timer to start the timer (and clear the manual update bit).

If the timer is stopped by force, the TCNTn retains the counter value and is not reloaded from TCNTBn. If a new value has to be set, perform manual update.

NOTE

Whenever TOUT inverter on/off bit is changed, the TOUTn logic value will also be changed whether the timer runs. Therefore, it is desirable that the inverter on/off bit is configured with the manual update bit.

TIMER OPERATION

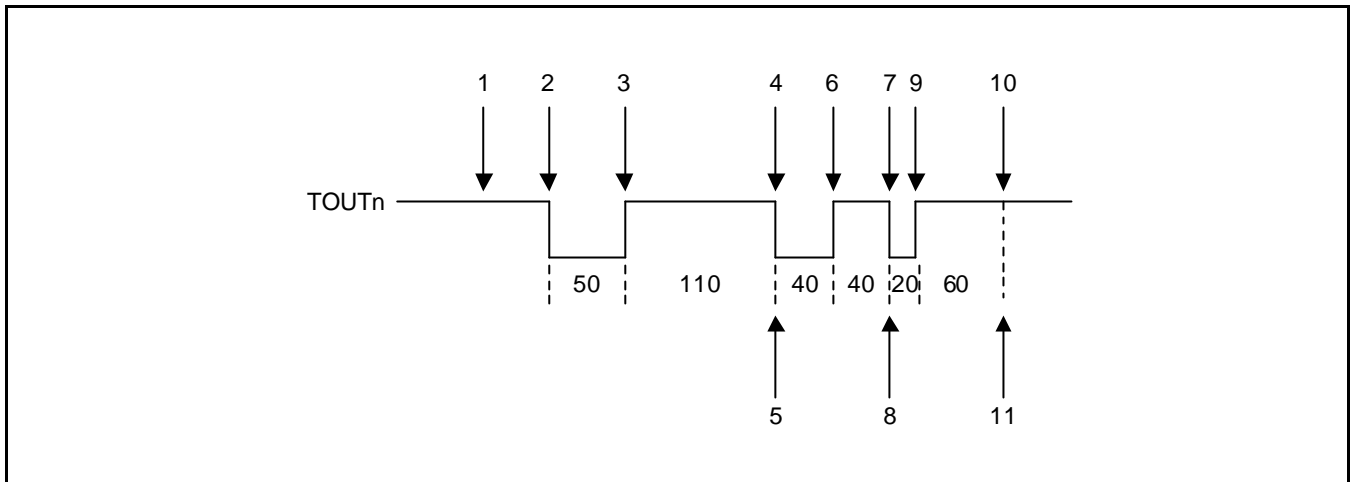

Figure 10-4. Example of a Timer Operation

The above Figure 10-4 shows the result of the following procedure:

1. Enable the auto re-load function. Set the TCNTBn to 160 (50+110) and the TCMPBn to 110. Set the manual update bit and configure the inverter bit (on/off). The manual update bit sets TCNTn and TCMPn to the values of TCNTBn and TCMPBn, respectively.
And then, set the TCNTBn and the TCMPBn to 80 (40+40) and 40, respectively, to determine the next reload value.
2. Set the start bit, provided that manual_update is 0 and the inverter is off and auto reload is on. The timer starts counting down after latency time within the timer resolution.
3. When the TCNTn has the same value as that of the TCMPn, the logic level of the TOUTn is changed from low to high.
4. When the TCNTn reaches 0, the interrupt request is generated and TCNTBn value is loaded into a temporary register. At the next timer tick, the TCNTn is reloaded with the temporary register value (TCNTBn).
5. In Interrupt Service Routine (ISR), the TCNTBn and the TCMPBn are set to 80 (20+60) and 60, respectively, for the next duration.
6. When the TCNTn has the same value as the TCMPn, the logic level of TOUTn is changed from low to high.
7. When the TCNTn reaches 0, the TCNTn is reloaded automatically with the TCNTBn, triggering an interrupt request.
8. In Interrupt Service Routine (ISR), auto reload and interrupt request are disabled to stop the timer.
9. When the value of the TCNTn is same as the TCMPn, the logic level of the TOUTn is changed from low to high.
10. Even when the TCNTn reaches 0, the TCNTn is not any more reloaded and the timer is stopped because auto reload has been disabled.
11. No more interrupt requests are generated.

PULSE WIDTH MODULATION (PWM)

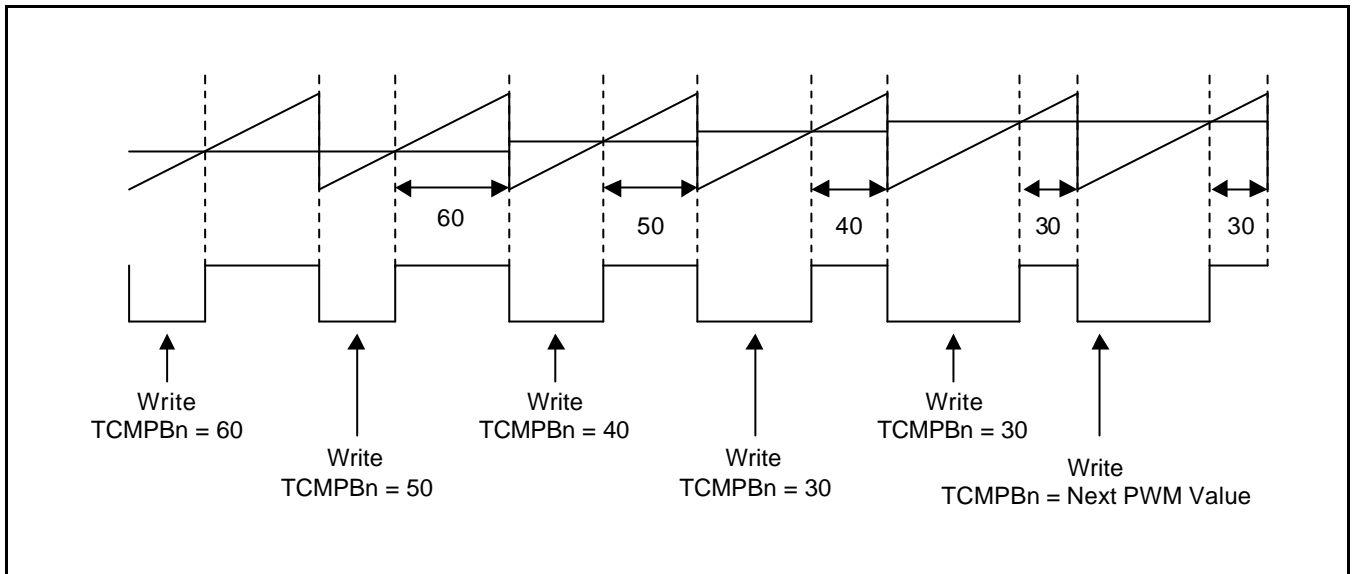

Figure 10-5. Example of PWM

PWM function can be implemented by using the TCMPBn. PWM frequency is determined by TCNTBn. Figure 10-5 shows a PWM value determined by TCMPBn.

For a higher PWM value, decrease the TCMPBn value. For a lower PWM value, increase the TCMPBn value. If an output inverter is enabled, the increment/decrement may be reversed.

The double buffering function allows the TCMPBn, for the next PWM cycle, written at any point in the current PWM cycle by ISR or other routine.

OUTPUT LEVEL CONTROL

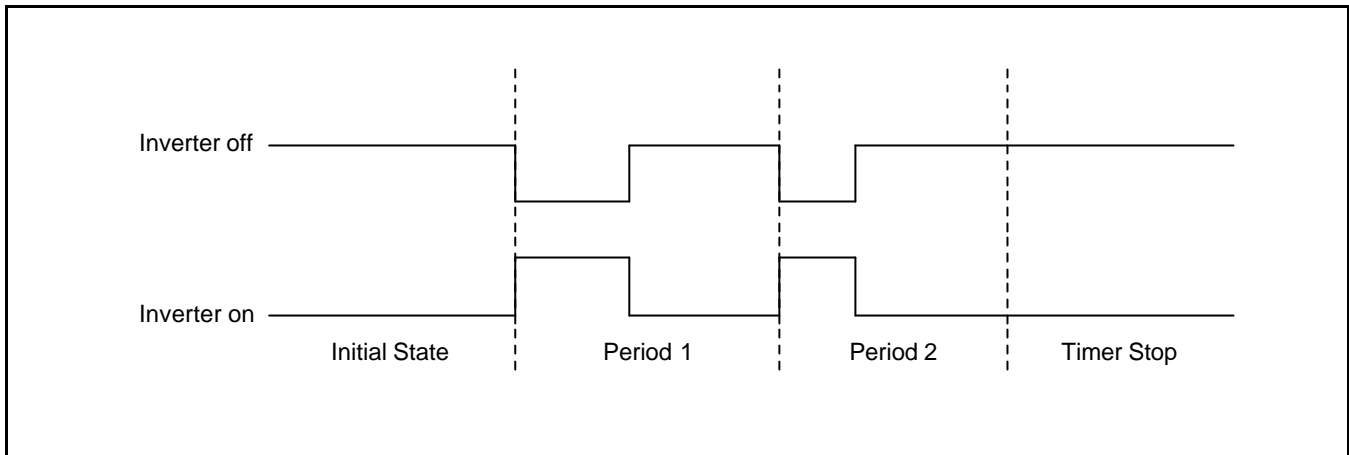
**Figure 10-6. Inverter On/Off**

The following procedure describes how to maintain TOUT as high or low (assume the inverter is off):

1. Turn off the auto reload bit. And then, TOUTn goes to high level and the timer is stopped after the TCNTn reaches 0 (recommended).
2. Stop the timer by clearing the timer start/stop bit to 0. If $TCNTn < TCMPn$, the output level is high. If $TCNTn > TCMPn$, the output level is low.
3. The TOUTn can be inverted by the inverter on/off bit in TCON. The inverter removes the additional circuit to adjust the output level.

DEAD ZONE GENERATOR

The Dead Zone is for the PWM control in a power device. This function enables the insertion of the time gap between a turn-off of a switching device and a turn on of another switching device. This time gap prohibits the two switching devices from being turned on simultaneously, even for a very short time.

TOUT0 is the PWM output. nTOUT0 is the inversion of the TOUT0. If the dead zone is enabled, the output wave form of TOUT0 and nTOUT0 will be TOUT0_DZ and nTOUT0_DZ, respectively. nTOUT0_DZ is routed to the TOUT1 pin.

In the dead zone interval, TOUT0_DZ and nTOUT0_DZ can never be turned on simultaneously.

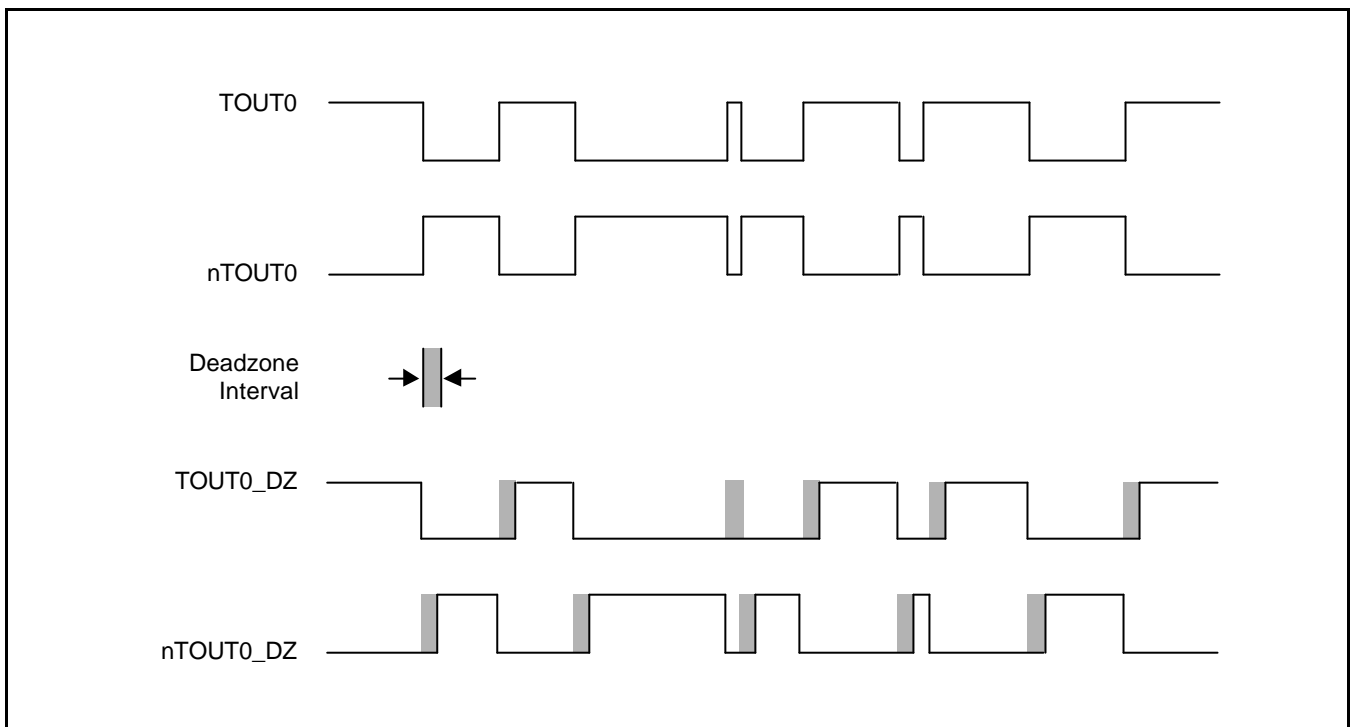

Figure 10-7. The Wave Form When a Dead Zone Feature is Enabled

DMA REQUEST MODE

The PWM timer can generate a DMA request at every specific time. The timer keeps DMA request signals (nDMA_REQ) low until the timer receives an ACK signal. When the timer receives the ACK signal, it makes the request signal inactive. The timer, which generates the DMA request, is determined by setting DMA mode bits (in TCFG1 register). If one of timers is configured as DMA request mode, that timer does not generate an interrupt request. The others can generate interrupt normally.

DMA mode configuration and DMA / interrupt operation

DMA Mode	DMA Request	Timer0 INT	Timer1 INT	Timer2 INT	Timer3 INT	Timer4 INT
0000	No select	ON	ON	ON	ON	ON
0001	Timer0	OFF	ON	ON	ON	ON
0010	Timer1	ON	OFF	ON	ON	ON
0011	Timer2	ON	ON	OFF	ON	ON
0100	Timer3	ON	ON	ON	OFF	ON
0101	Timer4	ON	ON	ON	ON	OFF
0110	No select	ON	ON	ON	ON	ON

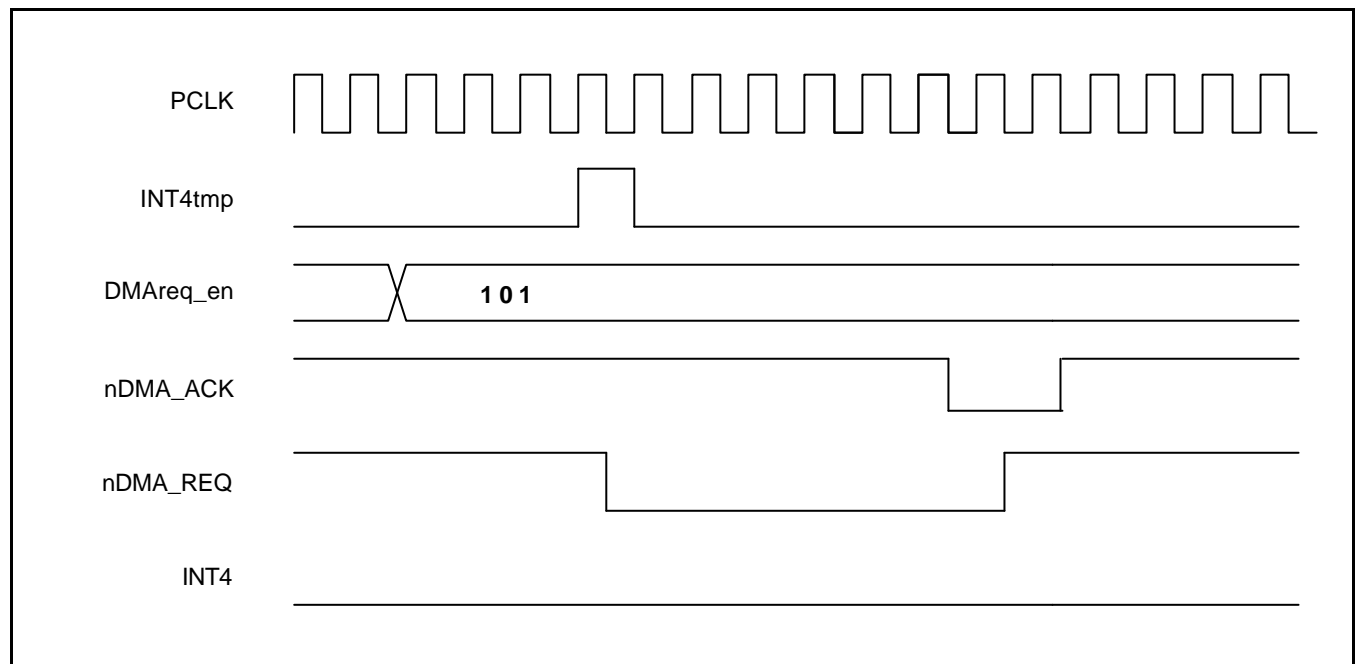

Figure 10-8. Timer4 DMA Mode Operation

PWM TIMER CONTROL REGISTERS

TIMER CONFIGURATION REGISTER0 (TCFG0)

Timer input clock Frequency = $PCLK / \{prescaler\ value + 1\} / \{divider\ value\}$

{prescaler value} = 0~255

{divider value} = 2, 4, 8, 16

Register	Address	R/W	Description	Reset Value
TCFG0	0x51000000	R/W	Configures the two 8-bit prescalers	0x00000000

TCFG0	Bit	Description	Initial State
Reserved	[31:24]		0x00
Dead zone length	[23:16]	These 8 bits determine the dead zone length. The 1 unit time of the dead zone length is equal to that of timer 0.	0x00
Prescaler 1	[15:8]	These 8 bits determine prescaler value for Timer 2, 3 and 4.	0x00
Prescaler 0	[7:0]	These 8 bits determine prescaler value for Timer 0 and 1.	0x00

TIMER CONFIGURATION REGISTER1 (TCFG1)

Register	Address	R/W	Description	Reset Value
TCFG1	0x51000004	R/W	5-MUX & DMA mode selection register	0x00000000

TCFG1	Bit	Description	Initial State
Reserved	[31:24]		00000000
DMA mode	[23:20]	Select DMA request channel 0000 = No select (all interrupt) 0001 = Timer0 0010 = Timer1 0011 = Timer2 0100 = Timer3 0101 = Timer4 0110 = Reserved	0000
MUX 4	[19:16]	Select MUX input for PWM Timer4. 0000 = 1/2 0001 = 1/4 0010 = 1/8 0011 = 1/16 01xx = External TCLK1	0000
MUX 3	[15:12]	Select MUX input for PWM Timer3. 0000 = 1/2 0001 = 1/4 0010 = 1/8 0011 = 1/16 01xx = External TCLK1	0000
MUX 2	[11:8]	Select MUX input for PWM Timer2. 0000 = 1/2 0001 = 1/4 0010 = 1/8 0011 = 1/16 01xx = External TCLK1	0000
MUX 1	[7:4]	Select MUX input for PWM Timer1. 0000 = 1/2 0001 = 1/4 0010 = 1/8 0011 = 1/16 01xx = External TCLK0	0000
MUX 0	[3:0]	Select MUX input for PWM Timer0. 0000 = 1/2 0001 = 1/4 0010 = 1/8 0011 = 1/16 01xx = External TCLK0	0000

TIMER CONTROL (TCON) REGISTER

Register	Address	R/W	Description	Reset Value
TCON	0x51000008	R/W	Timer control register	0x00000000

TCON	Bit	Description	Initial state
Timer 4 auto reload on/off	[22]	Determine auto reload on/off for Timer 4. 0 = One-shot 1 = Interval mode (auto reload)	0
Timer 4 manual update (note)	[21]	Determine the manual update for Timer 4. 0 = No operation 1 = Update TCNTB4	0
Timer 4 start/stop	[20]	Determine start/stop for Timer 4. 0 = Stop 1 = Start for Timer 4	0
Timer 3 auto reload on/off	[19]	Determine auto reload on/off for Timer 3. 0 = One-shot 1 = Interval mode (auto reload)	0
Timer 3 output inverter on/off	[18]	Determine output inverter on/off for Timer 3. 0 = Inverter off 1 = Inverter on for TOUT3	0
Timer 3 manual update (note)	[17]	Determine manual update for Timer 3. 0 = No operation 1 = Update TCNTB3 & TCMPB3	0
Timer 3 start/stop	[16]	Determine start/stop for Timer 3. 0 = Stop 1 = Start for Timer 3	0
Timer 2 auto reload on/off	[15]	Determine auto reload on/off for Timer 2. 0 = One-shot 1 = Interval mode (auto reload)	0
Timer 2 output inverter on/off	[14]	Determine output inverter on/off for Timer 2. 0 = Inverter off 1 = Inverter on for TOUT2	0
Timer 2 manual update (note)	[13]	Determine the manual update for Timer 2. 0 = No operation 1 = Update TCNTB2 & TCMPB2	0
Timer 2 start/stop	[12]	Determine start/stop for Timer 2. 0 = Stop 1 = Start for Timer 2	0
Timer 1 auto reload on/off	[11]	Determine the auto reload on/off for Timer1. 0 = One-shot 1 = Interval mode (auto reload)	0
Timer 1 output inverter on/off	[10]	Determine the output inverter on/off for Timer1. 0 = Inverter off 1 = Inverter on for TOUT1	0
Timer 1 manual update (note)	[9]	Determine the manual update for Timer 1. 0 = No operation 1 = Update TCNTB1 & TCMPB1	0
Timer 1 start/stop	[8]	Determine start/stop for Timer 1. 0 = Stop 1 = Start for Timer 1	0

NOTE: The bits have to be cleared at next writing.

TIMER CONTROL (TCON) REGISTER (Continued)

TCON	Bit	Description	Initial state
Reserved	[7:5]	Reserved	
Dead zone enable	[4]	Determine the dead zone operation. 0 = Disable 1 = Enable	0
Timer 0 auto reload on/off	[3]	Determine auto reload on/off for Timer 0. 0 = One-shot 1 = Interval mode(auto reload)	0
Timer 0 output inverter on/off	[2]	Determine the output inverter on/off for Timer 0. 0 = Inverter off 1 = Inverter on for TOUT0	0
Timer 0 manual update ^(note)	[1]	Determine the manual update for Timer 0. 0 = No operation 1 = Update TCNTB0 & TCMPB0	0
Timer 0 start/stop	[0]	Determine start/stop for Timer 0. 0 = Stop 1 = Start for Timer 0	0

NOTE: The bit has to be cleared at next writing.

TIMER 0 COUNT BUFFER REGISTER & COMPARE BUFFER REGISTER (TCNTB0/TCMPB0)

Register	Address	R/W	Description	Reset Value
TCNTB0	0x5100000C	R/W	Timer 0 count buffer register	0x00000000
TCMPB0	0x51000010	R/W	Timer 0 compare buffer register	0x00000000

TCMPB0	Bit	Description	Initial State
Timer 0 compare buffer register	[15:0]	Set compare buffer value for Timer 0	0x00000000

TCNTB0	Bit	Description	Initial State
Timer 0 count buffer register	[15:0]	Set count buffer value for Timer 0	0x00000000

TIMER 0 COUNT OBSERVATION REGISTER (TCNT00)

Register	Address	R/W	Description	Reset Value
TCNT00	0x51000014	R	Timer 0 count observation register	0x00000000

TCNT00	Bit	Description	Initial State
Timer 0 observation register	[15:0]	Set count observation value for Timer 0	0x00000000

TIMER 1 COUNT BUFFER REGISTER & COMPARE BUFFER REGISTER (TCNTB1/TCMPB1)

Register	Address	R/W	Description	Reset Value
TCNTB1	0x51000018	R/W	Timer 1 count buffer register	0x00000000
TCMPB1	0x5100001C	R/W	Timer 1 compare buffer register	0x00000000

TCMPB1	Bit	Description	Initial State
Timer 1 compare buffer register	[15:0]	Set compare buffer value for Timer 1	0x00000000

TCNTB1	Bit	Description	Initial State
Timer 1 count buffer register	[15:0]	Set count buffer value for Timer 1	0x00000000

TIMER 1 COUNT OBSERVATION REGISTER (TCNTO1)

Register	Address	R/W	Description	Reset Value
TCNTO1	0x51000020	R	Timer 1 count observation register	0x00000000

TCNTO1	Bit	Description	initial state
Timer 1 observation register	[15:0]	Set count observation value for Timer 1	0x00000000

TIMER 2 COUNT BUFFER REGISTER & COMPARE BUFFER REGISTER (TCNTB2/TCMPB2)

Register	Address	R/W	Description	Reset Value
TCNTB2	0x51000024	R/W	Timer 2 count buffer register	0x00000000
TCMPB2	0x51000028	R/W	Timer 2 compare buffer register	0x00000000

TCMPB2	Bit	Description	Initial State
Timer 2 compare buffer register	[15:0]	Set compare buffer value for Timer 2	0x00000000

TCNTB2	Bit	Description	Initial State
Timer 2 count buffer register	[15:0]	Set count buffer value for Timer 2	0x00000000

TIMER 2 COUNT OBSERVATION REGISTER (TCNTO2)

Register	Address	R/W	Description	Reset Value
TCNTO2	0x5100002C	R	Timer 2 count observation register	0x00000000

TCNTO2	Bit	Description	Initial State
Timer 2 observation register	[15:0]	Set count observation value for Timer 2	0x00000000

TIMER 3 COUNT BUFFER REGISTER & COMPARE BUFFER REGISTER (TCNTB3/TCMPB3)

Register	Address	R/W	Description	Reset Value
TCNTB3	0x51000030	R/W	Timer 3 count buffer register	0x00000000
TCMPB3	0x51000034	R/W	Timer 3 compare buffer register	0x00000000

TCMPB3	Bit	Description	Initial State
Timer 3 compare buffer register	[15:0]	Set compare buffer value for Timer 3	0x00000000

TCNTB3	Bit	Description	Initial State
Timer 3 count buffer register	[15:0]	Set count buffer value for Timer 3	0x00000000

TIMER 3 COUNT OBSERVATION REGISTER (TCNTO3)

Register	Address	R/W	Description	Reset Value
TCNTO3	0x51000038	R	Timer 3 count observation register	0x00000000

TCNTO3	Bit	Description	Initial State
Timer 3 observation register	[15:0]	Set count observation value for Timer 3	0x00000000

TIMER 4 COUNT BUFFER REGISTER (TCNTB4)

Register	Address	R/W	Description	Reset Value
TCNTB4	0x5100003C	R/W	Timer 4 count buffer register	0x00000000

TCNTB4	Bit	Description	Initial State
Timer 4 count buffer register	[15:0]	Set count buffer value for Timer 4	0x00000000

TIMER 4 COUNT OBSERVATION REGISTER (TCNTO4)

Register	Address	R/W	Description	Reset Value
TCNTO4	0x51000040	R	Timer 4 count observation register	0x00000000

TCNTO4	Bit	Description	Initial State
Timer 4 observation register	[15:0]	Set count observation value for Timer 4	0x00000000

NOTES

11

UART

OVERVIEW

The S3C2440A Universal Asynchronous Receiver and Transmitter (UART) provide three independent asynchronous serial I/O (SIO) ports, each of which can operate in Interrupt-based or DMA-based mode. In other words, the UART can generate an interrupt or a DMA request to transfer data between CPU and the UART. The UART can support bit rates up to 115.2K bps using system clock. If an external device provides the UART with UEXTCLK, then the UART can operate at higher speed. Each UART channel contains two 64-byte FIFOs for receiver and transmitter.

The S3C2440A UART includes programmable baud rates, infrared (IR) transmit/receive, one or two stop bit insertion, 5-bit, 6-bit, 7-bit or 8-bit data width and parity checking.

Each UART contains a baud-rate generator, transmitter, receiver and a control unit, as shown in Figure 11-1. The baud-rate generator can be clocked by PCLK, FCLK/n or UEXTCLK (external input clock). The transmitter and the receiver contain 64-byte FIFOs and data shifters. Data is written to FIFO and then copied to the transmit shifter before being transmitted. The data is then shifted out by the transmit data pin (TxDn). Meanwhile, received data is shifted from the receive data pin (RxDn), and then copied to FIFO from the shifter.

FEATURES

- RxD0, TxD0, RxD1, TxD1, RxD2, and TxD2 with DMA-based or interrupt-based operation
- UART Ch 0, 1, and 2 with IrDA 1.0 & 64-byte FIFO
- UART Ch 0 and 1 with nRTS0, nCTS0, nRTS1, and nCTS1
- Supports handshake transmit/receive

BLOCK DIAGRAM

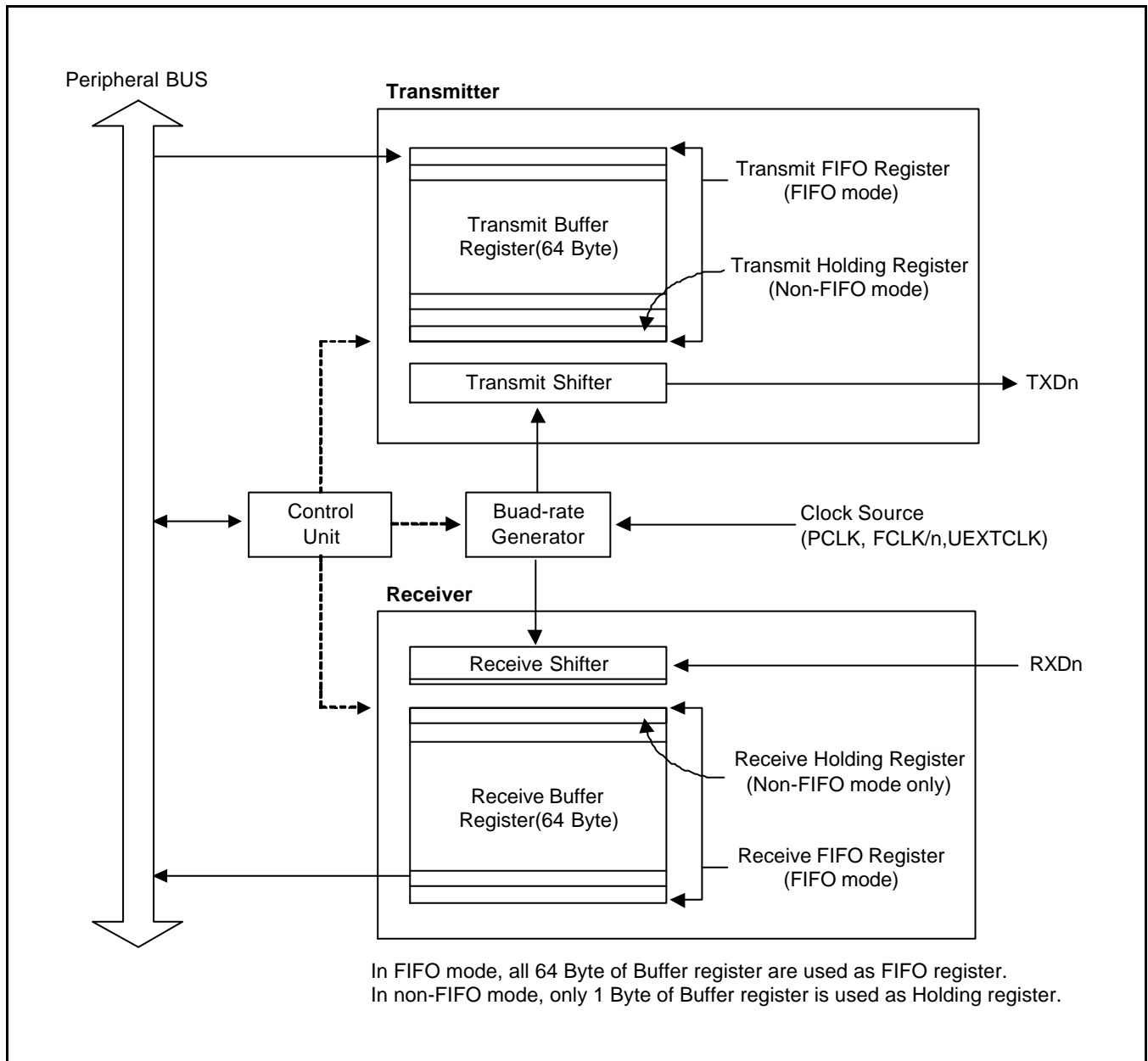

Figure 11-1. UART Block Diagram (with FIFO)

UART OPERATION

The following sections describe the UART operations that include data transmission, data reception, interrupt generation, baud-rate generation, Loopback mode, Infrared mode, and auto flow control.

Data Transmission

The data frame for transmission is programmable. It consists of a start bit, 5 to 8 data bits, an optional parity bit and 1 to 2 stop bits, which can be specified by the line control register (ULCONn). The transmitter can also produce the break condition, which forces the serial output to logic 0 state for one frame transmission time. This block transmits break signals after the present transmission word is transmitted completely. After the break signal transmission, it continuously transmits data into the Tx FIFO (Tx holding register in the case of Non-FIFO mode).

Data Reception

Like the transmission, the data frame for reception is also programmable. It consists of a start bit, 5 to 8 data bits, an optional parity bit and 1 to 2 stop bits in the line control register (ULCONn). The receiver can detect overrun error, parity error, frame error and break condition, each of which can set an error flag.

- The overrun error indicates that new data has overwritten the old data before the old data has been read.
- The parity error indicates that the receiver has detected an unexpected parity condition.
- The frame error indicates that the received data does not have a valid stop bit.
- The break condition indicates that the Rx Dn input is held in the logic 0 state for a duration longer than one frame transmission time.

Receive time-out condition occurs when it does not receive any data during the 3 word time (this interval follows the setting of Word Length bit) and the Rx FIFO is not empty in the FIFO mode.

Auto Flow Control (AFC)

The S3C2440A's UART 0 and UART 1 support auto flow control with nRTS and nCTS signals. In case, it can be connected to external UARTs. If users want to connect a UART to a Modem, disable auto flow control bit in UMCONn register and control the signal of nRTS by software.

In AFC, nRTS depends on the condition of the receiver and nCTS signals control the operation of the transmitter. The UART's transmitter transfers the data in FIFO only when nCTS signals are activated (in AFC, nCTS means that other UART's FIFO is ready to receive data). Before the UART receives data, nRTS has to be activated when its receive FIFO has a spare more than 32-byte and has to be inactivated when its receive FIFO has a spare under 32-byte (in AFC, nRTS means that its own receive FIFO is ready to receive data).

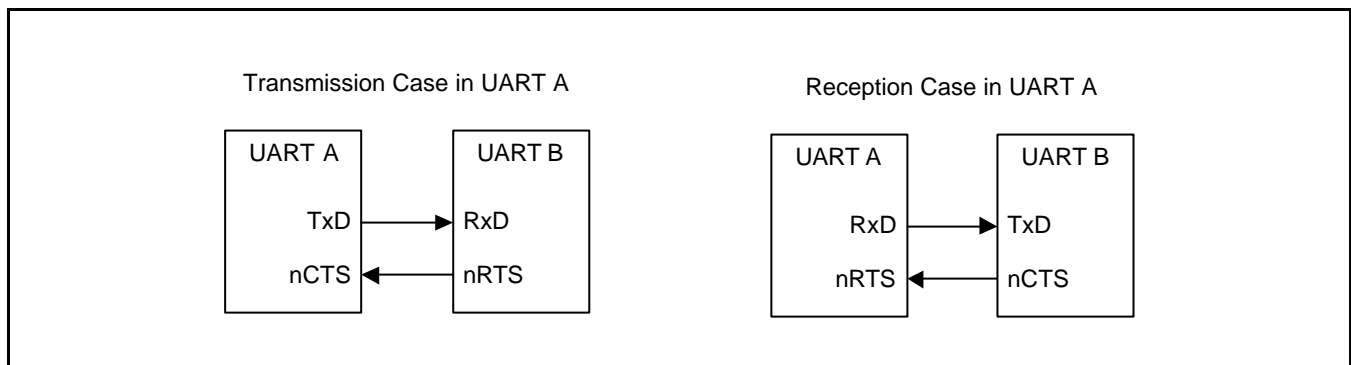

Figure 11-2. UART AFC interface

NOTE

UART 2 does not support AFC function, because the S3C2440A has no nRTS2 and nCTS2.

Example of Non Auto-Flow Control (Controlling nRTS and nCTS by Software)

Rx Operation with FIFO

1. Select receive mode (Interrupt or DMA mode).
2. Check the value of Rx FIFO count in UFSTATn register. If the value is less than 32, users have to set the value of UMCONn[0] to '1' (activating nRTS), and if it is equal or larger than 32 users have to set the value to '0' (inactivating nRTS).
3. Repeat the Step 2.

Tx Operation with FIFO

1. Select transmit mode (Interrupt or DMA mode).
2. Check the value of UMSTATn[0]. If the value is '1' (activating nCTS), users write the data to Tx FIFO register.

RS-232C interface

If the user wants to connect the UART to modem interface (instead of null modem), nRTS, nCTS, nDSR, nDTR, DCD and nRI signals are needed. In this case, the users can control these signals with general I/O ports by software because the AFC does not support the RS-232C interface.

Interrupt/DMA Request Generation

Each UART of the S3C2440A has seven status (Tx/Rx/Error) signals: Overrun error, Parity error, Frame error, Break, Receive buffer data ready, Transmit buffer empty, and Transmit shifter empty, all of which are indicated by the corresponding UART status register (UTRSTATn/UERSTATn).

The overrun error, parity error, frame error and break condition are referred to as the receive error status. Each of which can cause the receive error status interrupt request, if the receive-error-status-interrupt-enable bit is set to one in the control register, UCONn. When a receive-error-status-interrupt-request is detected, the signal causing the request can be identified by reading the value of UERSTSTn.

When the receiver transfers the data of the receive shifter to the receive FIFO register in FIFO mode and the number of received data reaches Rx FIFO Trigger Level, Rx interrupt is generated. If the Receive mode is in control register (UCONn) and is selected as 1 (Interrupt request or polling mode). In the Non-FIFO mode, transferring the data of the receive shifter to receive holding register will cause Rx interrupt under the Interrupt request and polling mode.

When the transmitter transfers data from its transmit FIFO register to its transmit shifter and the number of data left in transmit FIFO reaches Tx FIFO Trigger Level, Tx interrupt is generated, if Transmit mode in control register is selected as Interrupt request or polling mode. In the Non-FIFO mode, transferring data from the transmit holding register to the transmit shifter will cause Tx interrupt under the Interrupt request and polling mode.

If the Receive mode and Transmit mode in control register are selected as the DMA request mode then DMA request occurs instead of Rx or Tx interrupt in the situation mentioned above.

Table 11-1. Interrupts in Connection with FIFO

Type	FIFO Mode	Non-FIFO Mode
Rx Interrupt	Generated whenever receive data reaches the trigger level of receive FIFO. Generated when the number of data in FIFO does not reaches Rx FIFO trigger Level and does not receive any data during 3 word time (receive time out). This interval follows the setting of Word Length bit.	Generated by the receiving holding register whenever receive buffer becomes full.
Tx Interrupt	Generated whenever transmit data reaches the trigger level of transmit FIFO (Tx FIFO trigger Level).	Generated by the transmitting holding register whenever transmit buffer becomes empty.
Error Interrupt	Generated when frame error, parity error, or break signal are detected. Generated when it gets to the top of the receive FIFO without reading out data in it (overrun error).	Generated by all errors. However if another error occurs at the same time, only one interrupt is generated.

UART Error Status FIFO

UART has the error status FIFO besides the Rx FIFO register. The error status FIFO indicates which data, among FIFO registers, is received with an error. The error interrupt will be issued only when the data, which has an error, is ready to read out. To clear the error status FIFO, the URXHn with an error and UERSTATn must be read out.

For example,

It is assumed that the UART Rx FIFO receives A, B, C, D and E characters sequentially and the frame error occurs while receiving 'B', and the parity error occurs while receiving 'D'.

The actual UART receive error will not generate any error interrupt because the character which is received with an error would have not been read. The error interrupt will occur once the character is read.

Figure 11-3 shows the UART receiving the five characters including the two errors.

Time	Sequence Flow	Error Interrupt	Note
#0	When no character is read out	–	
#1	A, B, C, D, and E is received	–	
#2	After A is read out	The frame error (in B) interrupt occurs.	The 'B' has to be read out.
#3	After B is read out	–	
#4	After C is read out	The parity error (in D) interrupt occurs.	The 'D' has to be read out.
#5	After D is read out	–	
#6	After E is read out	–	

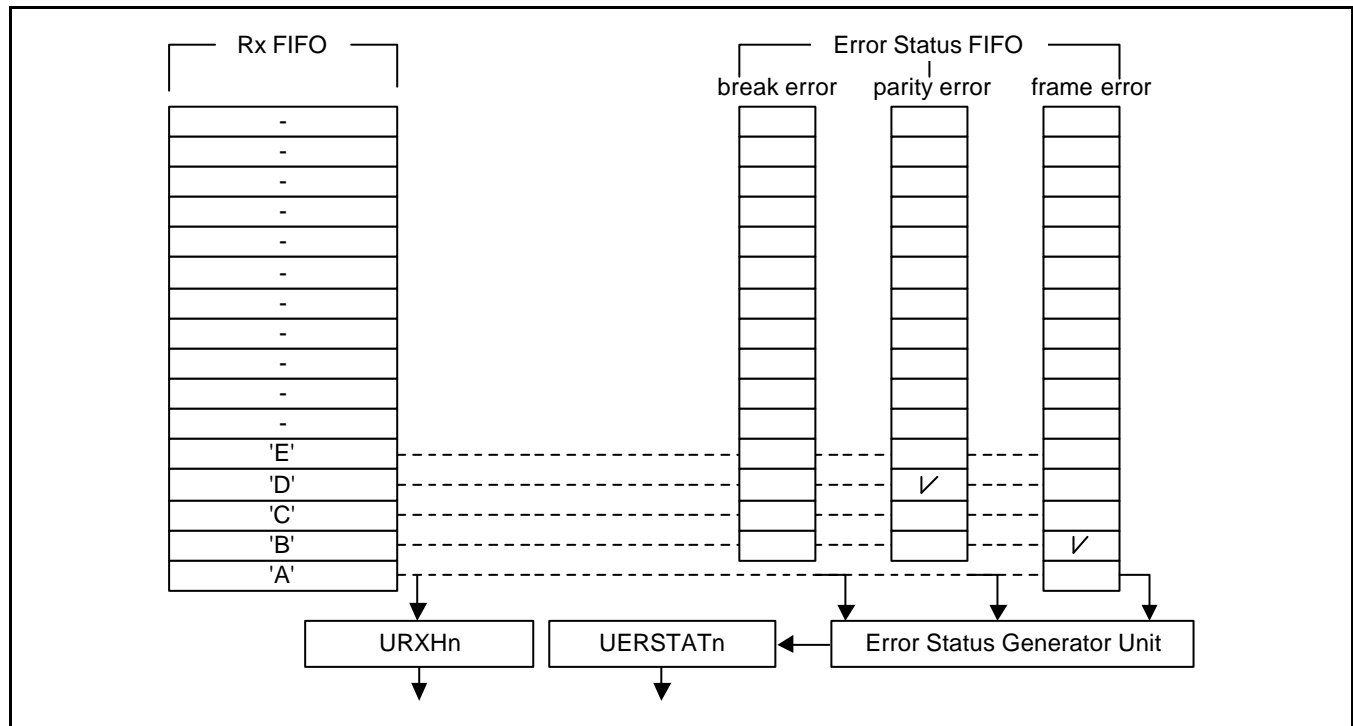

Figure 11-3. Example showing UART Receiving 5 Characters with 2 Errors

Baud-rate Generation

Each UART's baud-rate generator provides the serial clock for the transmitter and the receiver. The source clock for the baud-rate generator can be selected with the S3C2440A's internal system clock or UEXTCLK. In other words, dividend is selectable by setting Clock Selection of UCONn. The baud-rate clock is generated by dividing the source clock (PCLK, FCLK/n or UEXTCLK) by 16 and a 16-bit divisor specified in the UART baud-rate divisor register (UBRDIVn). The UBRDIVn can be determined by the following expression:

$$\text{UBRDIVn} = (\text{int})(\text{UART clock} / (\text{baud rate} \times 16)) - 1$$

(UART clock: PCLK, FCLK/n or UEXTCLK)

Where, UBRDIVn should be from 1 to $(2^{16}-1)$, but can be set 0 (bypass mode) only using the UEXTCLK which should be smaller than PCLK.

For example, if the baud-rate is 115200 bps and UART clock is 40 MHz, UBRDIVn is:

$$\begin{aligned} \text{UBRDIVn} &= (\text{int})(40000000 / (115200 \times 16)) - 1 \\ &= (\text{int})(21.7) - 1 \quad [\text{round to the nearest whole number}] \\ &= 22 - 1 = 21 \end{aligned}$$

Baud-Rate Error Tolerance

UART Frame error should be less than 1.87%(3/160).

$$t_{\text{UPCLK}} = (\text{UBRDIVn} + 1) \times 16 \times 1\text{Frame} / \text{PCLK}$$

t_{UPCLK} : Real UART Clock

$$t_{\text{UEXACT}} = 1\text{Frame} / \text{baud-rate}$$

t_{UEXACT} : Ideal UART Clock

$$\text{UART error} = (t_{\text{UPCLK}} - t_{\text{UEXACT}}) / t_{\text{UEXACT}} \times 100\%$$

NOTES

- 1Frame = start bit + data bit + parity bit + stop bit.
2. In specific condition, we can support the UART baud rate up to 921.6K bps. For example, when PCLK is 60MHz, you can use 921.6K bps under UART error of 1.69%.

Loopback Mode

The S3C2440A UART provides a test mode referred to as the Loopback mode, to aid in isolating faults in the communication link. This mode structurally enables the connection of RXD and TXD in the UART. In this mode, therefore, transmitted data is received to the receiver, via RXD. This feature allows the processor to verify the internal transmit and to receive the data path of each SIO channel. This mode can be selected by setting the loopback bit in the UART control register (UCONn).

Infrared (IR) Mode

The S3C2440A UART block supports infrared (IR) transmission and reception, which can be selected by setting the Infrared-mode bit in the UART line control register (ULCONn). Figure 11-4 illustrates how to implement the IR mode.

In IR transmit mode, the transmit pulse comes out at a rate of 3/16, the normal serial transmit rate (when the transmit data bit is zero); In IR receive mode, the receiver must detect the 3/16 pulsed period to recognize a zero value (see the frame timing diagrams shown in Figure 11-6 and 11-7).

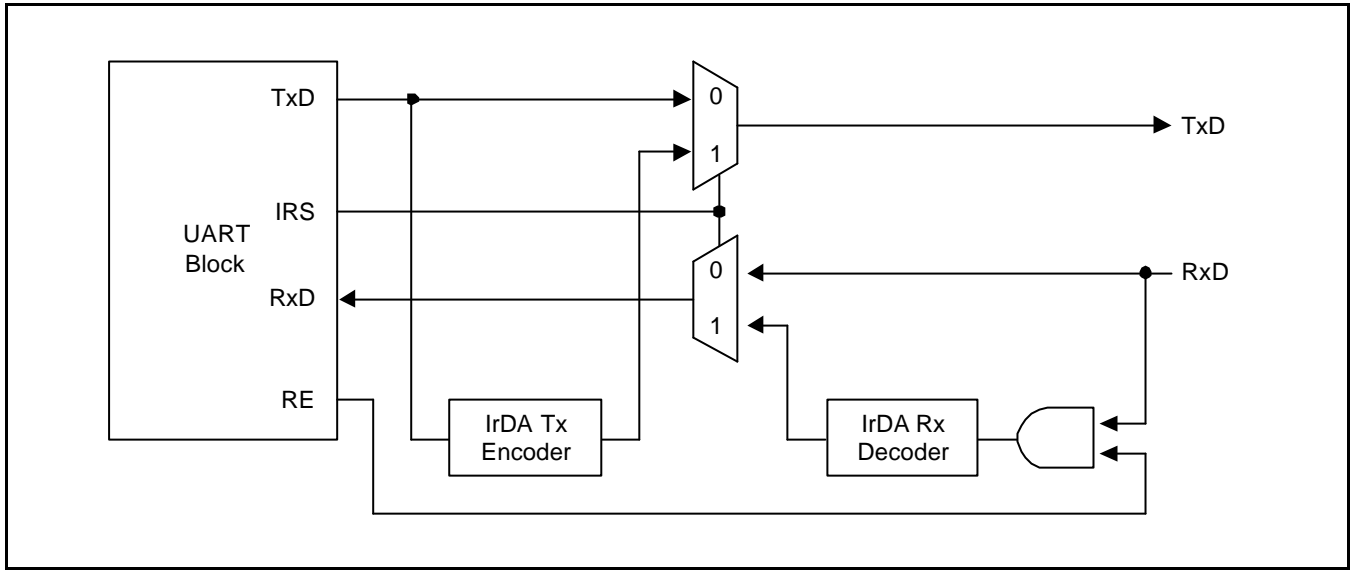

Figure 11-4. IrDA Function Block Diagram

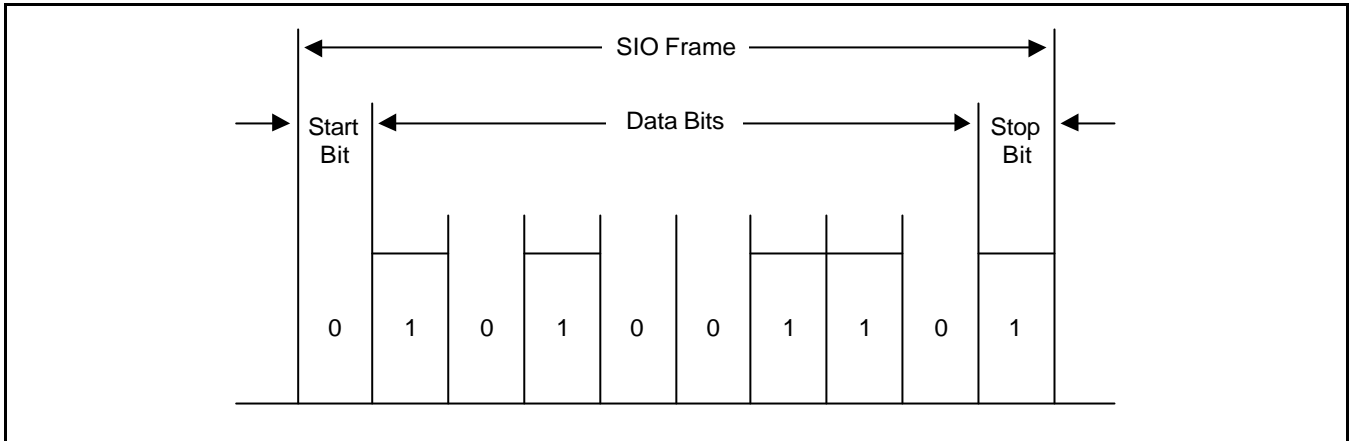

Figure 11-5. Serial I/O Frame Timing Diagram (Normal UART)

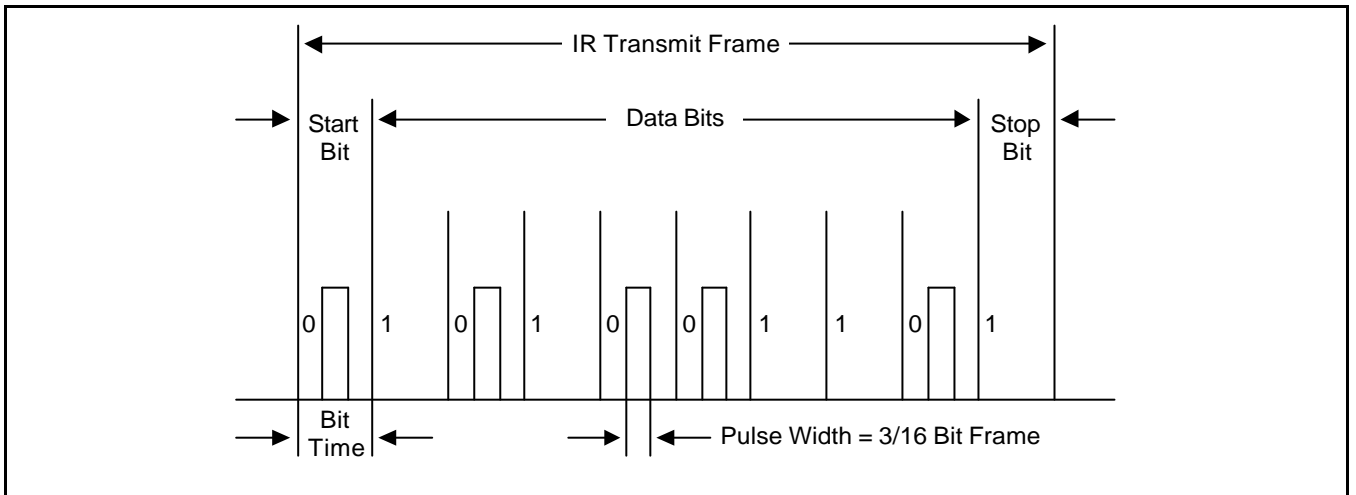

Figure 11-6. Infrared Transmit Mode Frame Timing Diagram

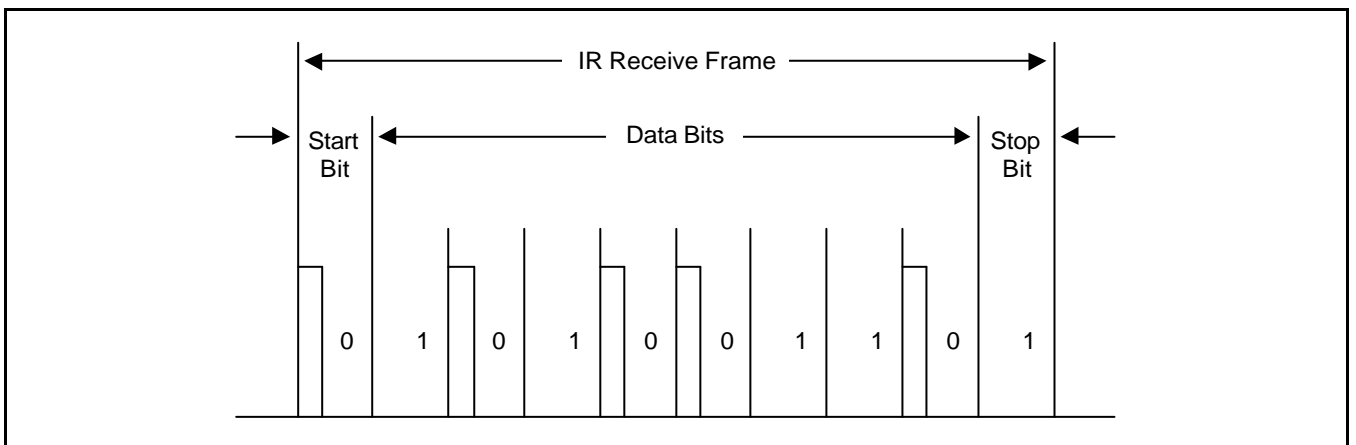

Figure 11-7. Infrared Receive Mode Frame Timing Diagram

UART SPECIAL REGISTERS

UART LINE CONTROL REGISTER

There are three UART line control registers including ULCON0, ULCON1, and ULCON2 in the UART block.

Register	Address	R/W	Description	Reset Value
ULCON0	0x50000000	R/W	UART channel 0 line control register	0x00
ULCON1	0x50004000	R/W	UART channel 1 line control register	0x00
ULCON2	0x50008000	R/W	UART channel 2 line control register	0x00

ULCONn	Bit	Description	Initial State
Reserved	[7]	–	0
Infrared Mode	[6]	Determine whether or not to use the Infrared mode. 0 = Normal mode operation 1 = Infrared Tx/Rx mode	0
Parity Mode	[5:3]	Specify the type of parity generation and checking during UART transmit and receive operation. 0xx = No parity 100 = Odd parity 101 = Even parity 110 = Parity forced/checked as 1 111 = Parity forced/checked as 0	000
Number of Stop Bit	[2]	Specify how many stop bits are to be used for end-of-frame signal. 0 = One stop bit per frame 1 = Two stop bit per frame	0
Word Length	[1:0]	Indicate the number of data bits to be transmitted or received per frame. 00 = 5-bits 01 = 6-bits 10 = 7-bits 11 = 8-bits	00

UART CONTROL REGISTER

There are three UART control registers including UCON0, UCON1 and UCON2 in the UART block.

Register	Address	R/W	Description	Reset Value
UCON0	0x50000004	R/W	UART channel 0 control register	0x00
UCON1	0x50004004	R/W	UART channel 1 control register	0x00
UCON2	0x50008004	R/W	UART channel 2 control register	0x00

UCONn	Bit	Description	Initial State
FCLK Divider	[15:12]	<p>Divider value when the Uart clock source is selected as FCLK/n. 'n' is determined by UCON0[15:12], UCON1[15:12], UCON2[14:12].</p> <p>UCON2[15] is FCLK/n Clock Enable/Disable bit. For setting 'n' from 7 to 21, use UCON0[15:12], For setting 'n' from 22 to 36, use UCON1[15:12], For setting 'n' from 37 to 43, use UCON2[14:12],</p> <p>UCON2[15]: 0 = Disable FCLK/n clock. 1 = Enable FCLK/n clock.</p> <p>In case of UCON0, UART clock = FCLK / (divider+6), where divider>0. UCON1, UCON2 must be zero. ex) 1: UART clock = FCLK/7, 2: UART clock = FCLK/8 3: UART clock = FCLK/9, ... , 15: UART clock = FCLK/21</p> <p>In case of UCON1, UART clock = FCLK / (divider+21), where divider>0. UCON0, UCON2 must be zero. ex) 1: UART clock = FCLK/22, 2: UART clock = FCLK/23 3: UART clock = FCLK/24, ... , 15: UART clock = FCLK/36</p> <p>In case of UCON2, UART clock = FCLK / (divider+36), where divider>0. UCON0, UCON1 must be zero. ex) 1: UART clock = FCLK/37, 2: UART clock = FCLK/38 3: UART clock = FCLK/39, ... , 7: UART clock = FCLK/43</p> <p>If UCON0/1[15:12] and UCON2[14:12] are all '0', the divider will be 44, that is UART clock = FCLK/44</p> <p>Total division range is from 7 to 44.</p>	0000
Clock Selection	[11:10]	<p>Select PCLK, UEXTCLK or FCLK/n for the UART baud rate. $UBRDIV_n = (\text{int})(\text{selected clock} / (\text{baudrate} \times 16)) - 1$</p> <p>00, 10 = PCLK 01 = UEXTCLK 11 = FCLK/n</p> <p>(If you would select FCLK/n, you should add the code of "NOTE" after selecting or deselecting the FCLK/n.)</p>	0

UART CONTROL REGISTER (Continued)

UCONn	Bit	Description	Initial State
Tx Interrupt Type	[9]	Interrupt request type. 0 = Pulse (Interrupt is requested as soon as the Tx buffer becomes empty in Non-FIFO mode or reaches Tx FIFO Trigger Level in FIFO mode.) 1 = Level (Interrupt is requested while Tx buffer is empty in Non-FIFO mode or reaches Tx FIFO Trigger Level in FIFO mode.)	0
Rx Interrupt Type	[8]	Interrupt request type. 0 = Pulse (Interrupt is requested the instant Rx buffer receives the data in Non-FIFO mode or reaches Rx FIFO Trigger Level in FIFO mode.) 1 = Level (Interrupt is requested while Rx buffer is receiving data in Non-FIFO mode or reaches Rx FIFO Trigger Level in FIFO mode.)	0
Rx Time Out Enable	[7]	Enable/Disable Rx time out interrupt when UART FIFO is enabled. The interrupt is a receive interrupt. 0 = Disable 1 = Enable	0
Rx Error Status Interrupt Enable	[6]	Enable the UART to generate an interrupt upon an exception, such as a break, frame error, parity error, or overrun error during a receive operation. 0 = Do not generate receive error status interrupt. 1 = Generate receive error status interrupt.	0
Loopback Mode	[5]	Setting loopback bit to 1 causes the UART to enter the loopback mode. This mode is provided for test purposes only. 0 = Normal operation 1 = Loopback mode	0
Send Break Signal	[4]	Setting this bit causes the UART to send a break during 1 frame time. This bit is automatically cleared after sending the break signal. 0 = Normal transmit 1 = Send break signal	0

NOTE: You should add following codes after selecting or deselecting the FCLK/n.
`rGPHCON = rGPHCON & ~(3<<16); //GPH8(UEXTCLK) input`
`Delay(1); // about 100us`
`rGPHCON = rGPHCON & ~(3<<16) | (1<<17); //GPH8(UEXTCLK) UEXTCLK`

UART CONTROL REGISTER (Continued)

UCONn	Bit	Description	Initial State
Transmit Mode	[3:2]	Determine which function is currently able to write Tx data to the UART transmit buffer register. (UART Tx Enable/Disable) 00 = Disable 01 = Interrupt request or polling mode 10 = DMA0 request (Only for UART0), DMA3 request (Only for UART2) 11 = DMA1 request (Only for UART1)	00
Receive Mode	[1:0]	Determine which function is currently able to read data from UART receive buffer register. (UART Rx Enable/Disable) 00 = Disable 01 = Interrupt request or polling mode 10 = DMA0 request (Only for UART0), DMA3 request (Only for UART2) 11 = DMA1 request (Only for UART1)	00

NOTE: When the UART does not reach the FIFO trigger level and does not receive data during 3 word time in DMA receive mode with FIFO, the Rx interrupt will be generated (receive time out), and the users should check the FIFO status and read out the rest.

UART FIFO CONTROL REGISTER

There are three UART FIFO control registers including UFCON0, UFCON1 and UFCON2 in the UART block.

Register	Address	R/W	Description	Reset Value
UFCON0	0x50000008	R/W	UART channel 0 FIFO control register	0x0
UFCON1	0x50004008	R/W	UART channel 1 FIFO control register	0x0
UFCON2	0x50008008	R/W	UART channel 2 FIFO control register	0x0

UFCONn	Bit	Description	Initial State
Tx FIFO Trigger Level	[7:6]	Determine the trigger level of transmit FIFO. 00 = Empty 01 = 16-byte 10 = 32-byte 11 = 48-byte	00
Rx FIFO Trigger Level	[5:4]	Determine the trigger level of receive FIFO. 00 = 1-byte 01 = 8-byte 10 = 16-byte 11 = 32-byte	00
Reserved	[3]	–	0
Tx FIFO Reset	[2]	Auto-cleared after resetting FIFO 0 = Normal 1 = Tx FIFO reset	0
Rx FIFO Reset	[1]	Auto-cleared after resetting FIFO 0 = Normal 1 = Rx FIFO reset	0
FIFO Enable	[0]	0 = Disable 1 = Enable	0

NOTE: When the UART does not reach the FIFO trigger level and does not receive data during 3 word time in DMA receive mode with FIFO, the Rx interrupt will be generated (receive time out), and the users should check the FIFO status and read out the rest.

UART TX/RX STATUS REGISTER

There are three UART Tx/Rx status registers including UTRSTAT0, UTRSTAT1 and UTRSTAT2 in the UART block.

Register	Address	R/W	Description	Reset Value
UTRSTAT0	0x50000010	R	UART channel 0 Tx/Rx status register	0x6
UTRSTAT1	0x50004010	R	UART channel 1 Tx/Rx status register	0x6
UTRSTAT2	0x50008010	R	UART channel 2 Tx/Rx status register	0x6

UTRSTATn	Bit	Description	Initial State
Transmitter empty	[2]	Set to 1 automatically when the transmit buffer register has no valid data to transmit and the transmit shift register is empty. 0 = Not empty 1 = Transmitter (transmit buffer & shifter register) empty	1
Transmit buffer empty	[1]	Set to 1 automatically when transmit buffer register is empty. 0 = The buffer register is not empty 1 = Empty (In Non-FIFO mode, Interrupt or DMA is requested. In FIFO mode, Interrupt or DMA is requested, when Tx FIFO Trigger Level is set to 00 (Empty)) If the UART uses the FIFO, users should check Tx FIFO Count bits and Tx FIFO Full bit in the UFSTAT register instead of this bit.	1
Receive buffer data ready	[0]	Set to 1 automatically whenever receive buffer register contains valid data, received over the RXDn port. 0 = Empty 1 = The buffer register has a received data (In Non-FIFO mode, Interrupt or DMA is requested) If the UART uses the FIFO, users should check Rx FIFO Count bits and Rx FIFO Full bit in the UFSTAT register instead of this bit.	0

UART ERROR STATUS REGISTER

There are three UART Rx error status registers including UERSTAT0, UERSTAT1 and UERSTAT2 in the UART block.

Register	Address	R/W	Description	Reset Value
UERSTAT0	0x50000014	R	UART channel 0 Rx error status register	0x0
UERSTAT1	0x50004014	R	UART channel 1 Rx error status register	0x0
UERSTAT2	0x50008014	R	UART channel 2 Rx error status register	0x0

UERSTATn	Bit	Description	Initial State
Break Detect	[3]	Set to 1 automatically to indicate that a break signal has been received. 0 = No break receive 1 = Break receive (Interrupt is requested.)	0
Frame Error	[2]	Set to 1 automatically whenever a frame error occurs during receive operation. 0 = No frame error during receive 1 = Frame error (Interrupt is requested.)	0
Parity Error	[1]	Set to 1 automatically whenever a parity error occurs during receive operation. 0 = No parity error during receive 1 = Parity error (Interrupt is requested.)	0
Overrun Error	[0]	Set to 1 automatically whenever an overrun error occurs during receive operation. 0 = No overrun error during receive 1 = Overrun error (Interrupt is requested.)	0

NOTE: These bits (UERSTATn[3:0]) are automatically cleared to 0 when the UART error status register is read.

UART FIFO STATUS REGISTER

There are three UART FIFO status registers including UFSTAT0, UFSTAT1 and UFSTAT2 in the UART block.

Register	Address	R/W	Description	Reset Value
UFSTAT0	0x50000018	R	UART channel 0 FIFO status register	0x00
UFSTAT1	0x50004018	R	UART channel 1 FIFO status register	0x00
UFSTAT2	0x50008018	R	UART channel 2 FIFO status register	0x00

UFSTATn	Bit	Description	Initial State
Reserved	[15]		0
Tx FIFO Full	[14]	Set to 1 automatically whenever transmit FIFO is full during transmit operation 0 = 0-byte ≤ Tx FIFO data ≤ 63-byte 1 = Full	0
Tx FIFO Count	[13:8]	Number of data in Tx FIFO	0
Reserved	[7]	–	0
Rx FIFO Full	[6]	Set to 1 automatically whenever receive FIFO is full during receive operation 0 = 0-byte ≤ Rx FIFO data ≤ 63-byte 1 = Full	0
Rx FIFO Count	[5:0]	Number of data in Rx FIFO	0

UART MODEM STATUS REGISTER

There are two UART modem status registers including UMSTAT0, UMSTAT1 in the UART block.

Register	Address	R/W	Description	Reset Value
UMSTAT0	0x5000001C	R	UART channel 0 modem status register	0x0
UMSTAT1	0x5000401C	R	UART channel 1 modem status register	0x0
Reserved	0x5000801C	–	Reserved	Undef

UMSTAT0	Bit	Description	Initial State
Delta CTS	[4]	Indicate that the nCTS input to the S3C2440A has changed state since the last time it was read by CPU. (Refer to Figure 11-8.) 0 = Has not changed 1 = Has changed	0
Reserved	[3:1]	–	0
Clear to Send	[0]	0 = CTS signal is not activated (nCTS pin is high) 1 = CTS signal is activated (nCTS pin is low)	0

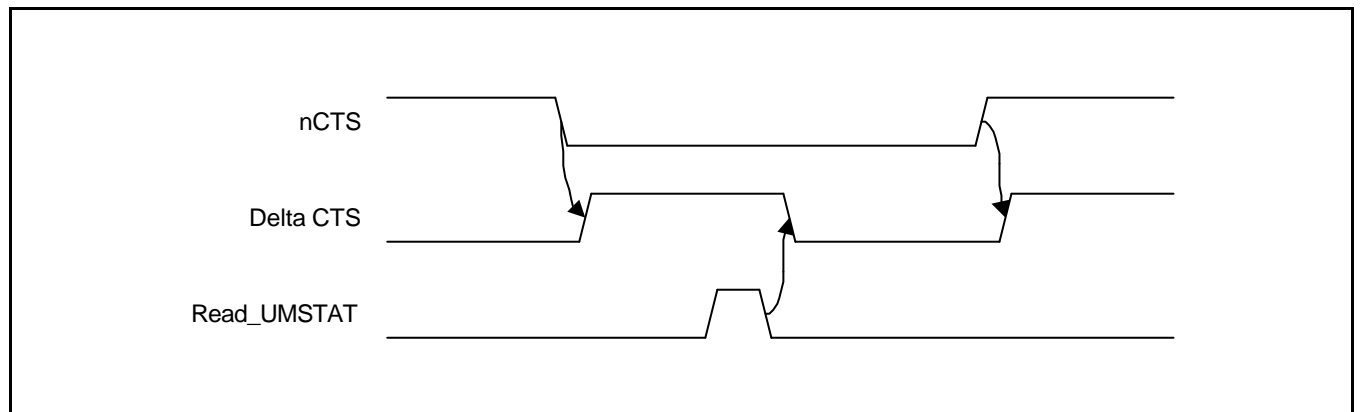

Figure 11-8. nCTS and Delta CTS Timing Diagram

UART TRANSMIT BUFFER REGISTER (HOLDING REGISTER & FIFO REGISTER)

There are three UART transmit buffer registers including UTXH0, UTXH1 and UTXH2 in the UART block. UTXHn has an 8-bit data for transmission data.

Register	Address	R/W	Description	Reset Value
UTXH0	0x50000020(L) 0x50000023(B)	W (by byte)	UART channel 0 transmit buffer register	–
UTXH1	0x50004020(L) 0x50004023(B)	W (by byte)	UART channel 1 transmit buffer register	–
UTXH2	0x50008020(L) 0x50008023(B)	W (by byte)	UART channel 2 transmit buffer register	–

UTXHn	Bit	Description	Initial State
TXDATAn	[7:0]	Transmit data for UARTn	–

NOTE: (L): The endian mode is Little endian.

(B): The endian mode is Big endian.

UART RECEIVE BUFFER REGISTER (HOLDING REGISTER & FIFO REGISTER)

There are three UART receive buffer registers including URXH0, URXH1 and URXH2 in the UART block. URXHn has an 8-bit data for received data.

Register	Address	R/W	Description	Reset Value
URXH0	0x50000024(L) 0x50000027(B)	R (by byte)	UART channel 0 receive buffer register	–
URXH1	0x50004024(L) 0x50004027(B)	R (by byte)	UART channel 1 receive buffer register	–
URXH2	0x50008024(L) 0x50008027(B)	R (by byte)	UART channel 2 receive buffer register	–

URXHn	Bit	Description	Initial State
RXDATAn	[7:0]	Receive data for UARTn	–

NOTE: When an overrun error occurs, the URXHn must be read. If not, the next received data will also make an overrun error, even though the overrun bit of UERSTATn had been cleared.

UART BAUD RATE DIVISOR REGISTER

There are three UART baud rate divisor registers including UBRDIV0, UBRDIV1 and UBRDIV2 in the UART block. The value stored in the baud rate divisor register (UBRDIVn), is used to determine the serial Tx/Rx clock rate (baud rate) as follows:

$$\text{UBRDIVn} = (\text{int})(\text{UART clock} / (\text{baud rate} \times 16)) - 1$$

(UART clock: PCLK, FCLK/n or UEXTCLK)

Where, UBRDIVn should be from 1 to $(2^{16}-1)$, but can be set zero only using the UEXTCLK which should be smaller than PCLK.

For example, if the baud-rate is 115200 bps and UART clock is 40 MHz, UBRDIVn is:

$$\begin{aligned} \text{UBRDIVn} &= (\text{int})(40000000 / (115200 \times 16)) - 1 \\ &= (\text{int})(21.7) - 1 \quad [\text{round to the nearest whole number}] \\ &= 22 - 1 = 21 \end{aligned}$$

Register	Address	R/W	Description	Reset Value
UBRDIV0	0x50000028	R/W	Baud rate divisor register 0	–
UBRDIV1	0x50004028	R/W	Baud rate divisor register 1	–
UBRDIV2	0x50008028	R/W	Baud rate divisor register 2	–

UBRDIVn	Bit	Description	Initial State
UBRDIV	[15:0]	Baud rate division value UBRDIVn > 0 Using the UEXTCLK as input clock, UBRDIVn can be set '0'.	–

NOTES

12 USB HOST CONTROLLER

OVERVIEW

S3C2440A supports 2-port USB host interface as follows:

- OHCI Rev 1.0 compatible
- USB Rev1.1 compatible
- Two down stream ports
- Support for both LowSpeed and FullSpeed USB devices

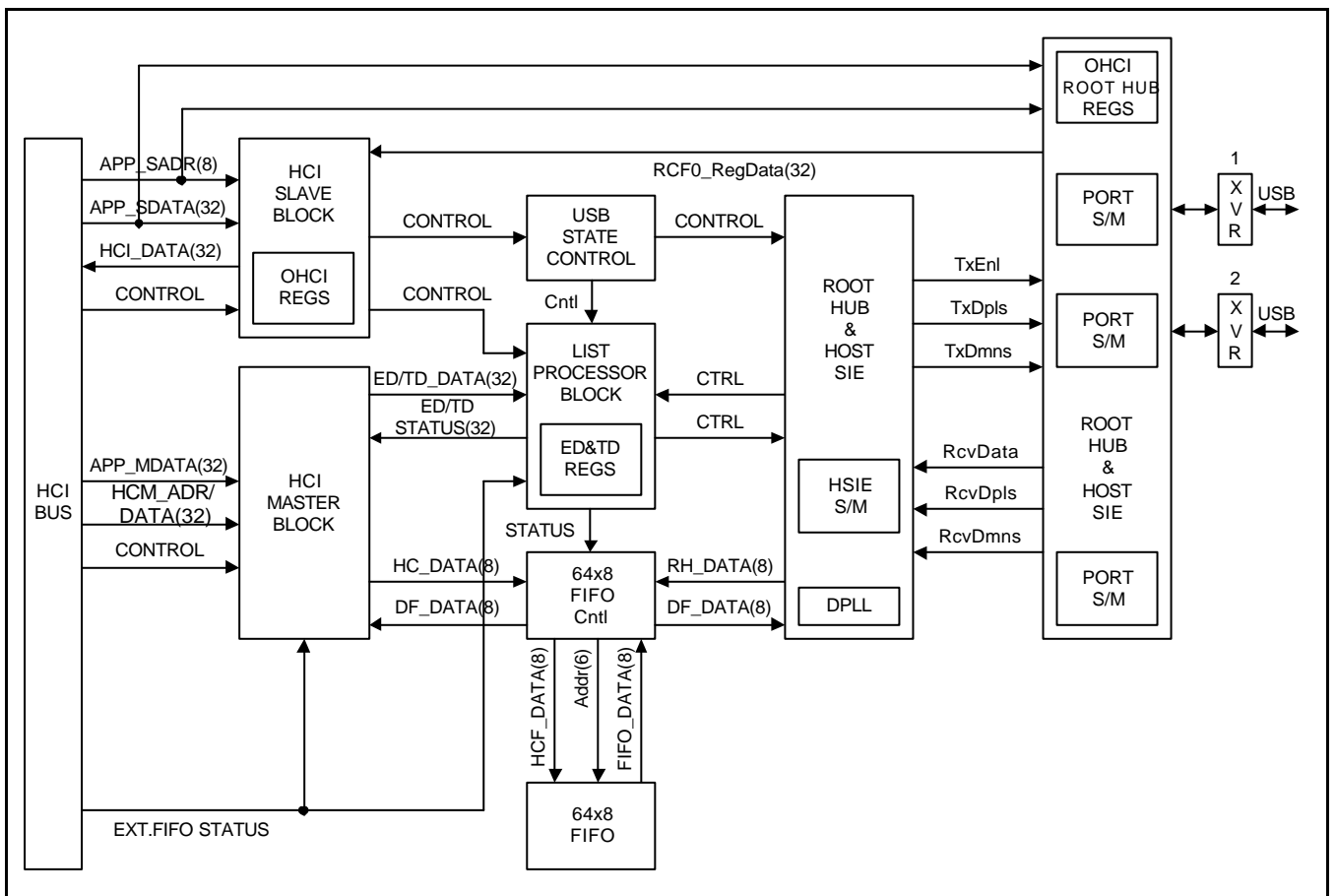

Figure 12-1. USB Host Controller Block Diagram

USB HOST CONTROLLER SPECIAL REGISTERS

The S3C2440A USB host controller complies with OHCI Rev 1.0. Refer to Open Host Controller Interface Rev 1.0 specification for detailed information.

OHCI REGISTERS FOR USB HOST CONTROLLER

Register	Base Address	R/W	Description	Reset Value
HcRevision	0x49000000	–	Control and status group	–
HcControl	0x49000004	–		–
HcCommonStatus	0x49000008	–		–
HcInterruptStatus	0x4900000C	–		–
HcInterruptEnable	0x49000010	–		–
HcInterruptDisable	0x49000014	–		–
HcHCCA	0x49000018	–	Memory pointer group	–
HcPeriodCurrentED	0x4900001C	–		–
HcControlHeadED	0x49000020	–		–
HcControlCurrentED	0x49000024	–		–
HcBulkHeadED	0x49000028	–		–
HcBulkCurrentED	0x4900002C	–		–
HcDoneHead	0x49000030	–		–
HcRmInterval	0x49000034	–	Frame counter group	–
HcFmRemaining	0x49000038	–		–
HcFmNumber	0x4900003C	–		–
HcPeriodicStart	0x49000040	–		–
HcLSThreshold	0x49000044	–		–
HcRhDescriptorA	0x49000048	–	Root hub group	–
HcRhDescriptorB	0x4900004C	–		–
HcRhStatus	0x49000050	–		–
HcRhPortStatus1	0x49000054	–		–
HcRhPortStatus2	0x49000058	–		–

13

USB DEVICE CONTROLLER

OVERVIEW

Universal Serial Bus (USB) device controller is designed to provide a high performance full speed function controller solution with DMA interface. USB device controller allows bulk transfer with DMA, interrupt transfer and control transfer.

USB Device Controller Supports:

- Full speed USB device controller compatible with the USB specification version 1.1
- DMA interface for bulk transfer
- Five endpoints with FIFO
 - EP0: 16byte (Register)
 - EP1: 128byte IN/OUT FIFO (dual port asynchronous RAM): interrupt or DMA
 - EP2: 128byte IN/OUT FIFO (dual port asynchronous RAM): interrupt or DMA
 - EP3: 128byte IN/OUT FIFO (dual port asynchronous RAM): interrupt or DMA
 - EP4: 128byte IN/OUT FIFO (dual port asynchronous RAM): interrupt or DMA
- Integrated USB Transceiver

FEATURE

- Fully compliant with USB Specification Version 1.1
- Full speed (12Mbps) device
- Integrated USB Transceiver
- Supports control, interrupt and bulk transfer
- Five endpoints with FIFO:
 - One bi-directional control endpoint with 16-byte FIFO (EP0)
 - Four bi-directional bulk endpoints with 128-byte FIFO (EP1, EP2, EP3, and EP4)
- Supports DMA interface for receive and transmit bulk endpoints. (EP1, EP2, EP3, and EP4)
- Independent 128-byte receive and transmit FIFO to maximize throughput
- Supports suspend and remote wakeup function

NOTE

PCLK should be more than 20MHz to use USB Controller in stable condition.

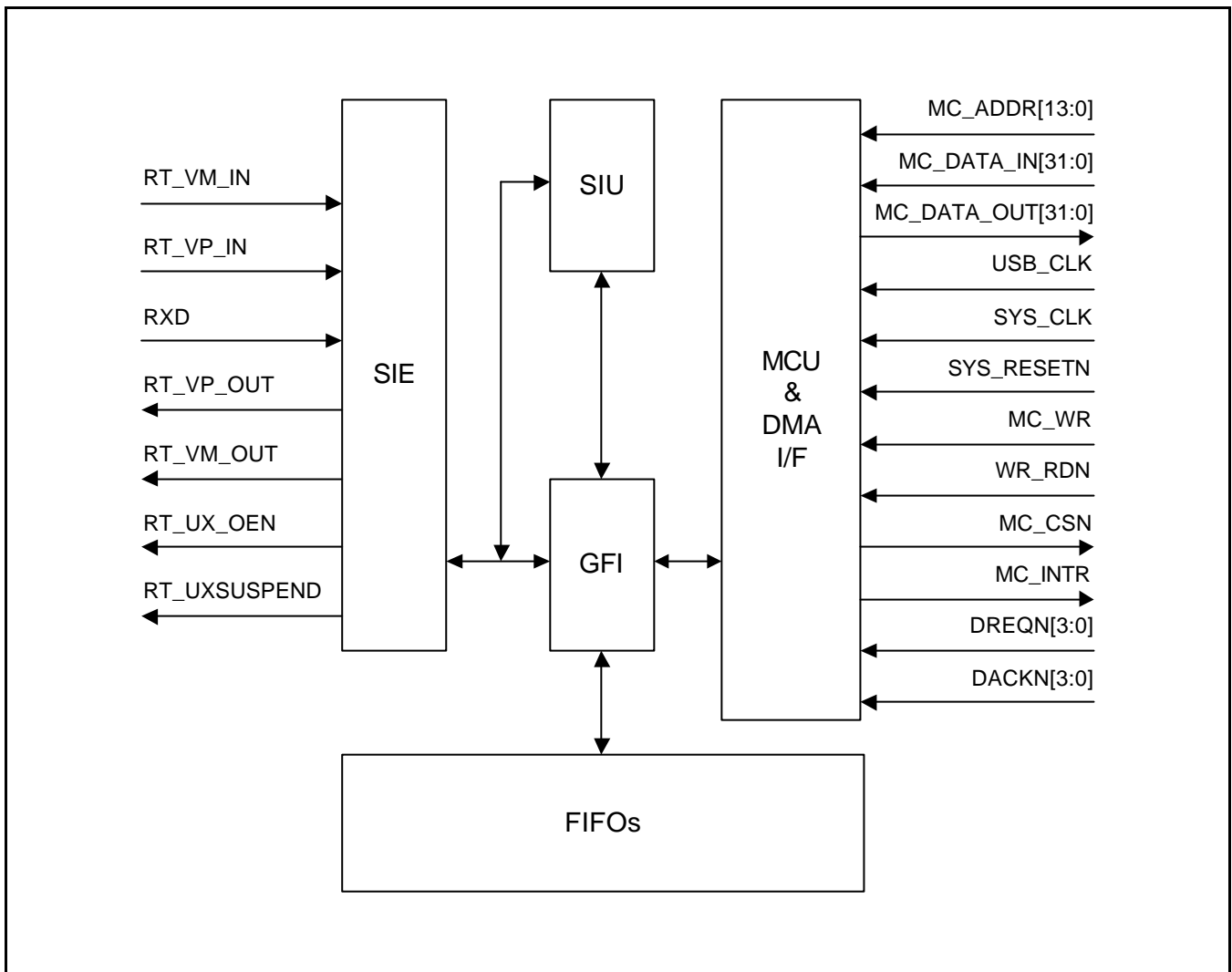

Figure 13-1. USB Device Controller Block Diagram

USB DEVICE CONTROLLER SPECIAL REGISTERS

This section describes detailed functionalities about register sets of USB device controller. All special function register is byte-accessible or word-accessible. If you access byte mode offset-address is different in little endian and big endian. All reserved bit is zero.

Common indexed registers depend on INDEX register (INDEX_REG) (offset address: 0X178) value. For example if you want to write EP0 CSR register, you must write '0x00' on the INDEX_REG before writing IN_CSR1 register.

NOTE

All register must be resettled after performing host reset signaling.

Register Name	Description	Offset Address
Non Indexed Registers		
FUNC_ADDR_REG	Function address register	0x140(L) / 0x143(B)
PWR_REG	Power management register	0x144(L) / 0x147(B)
EP_INT_REG (EP0–EP4)	Endpoint interrupt register	0x148(L) / 0x14B(B)
USB_INT_REG	USB interrupt register	0x158(L) / 0x15B(B)
EP_INT_EN_REG (EP0–EP4)	Endpoint interrupt enable register	0x15C(L) / 0x15F(B)
USB_INT_EN_REG	USB Interrupt enable register	0x16C(L) / 0x16F(B)
FRAME_NUM1_REG	Frame number 1 register	0x170(L) / 0x173(B)
FRAME_NUM2_REG	Frame number 2 register	0x174(L) / 0x177(B)
INDEX_REG	Index register	0x178(L) / 0x17B(B)
EP0_FIFO_REG	Endpoint0 FIFO register	0x1C0(L) / 0x1C3(B)
EP1_FIFO_REG	Endpoint1 FIFO register	0x1C4(L) / 0x1C7(B)
EP2_FIFO_REG	Endpoint2 FIFO register	0x1C8(L) / 0x1CB(B)
EP3_FIFO_REG	Endpoint3 FIFO register	0x1CC(L) / 0x1CF(B)
EP4_FIFO_REG	Endpoint4 FIFO register	0x1D0(L) / 0x1D3(B)
EP1_DMA_CON	Endpoint1 DMA control register	0x200(L) / 0x203(B)
EP1_DMA_UNIT	Endpoint1 DMA unit counter register	0x204(L) / 0x207(B)
EP1_DMA_FIFO	Endpoint1 DMA FIFO counter register	0x208(L) / 0x20B(B)
EP1_DMA_TTC_L	Endpoint1 DMA transfer counter low-byte register	0x20C(L) / 0x20F(B)
EP1_DMA_TTC_M	Endpoint1 DMA transfer counter middle-byte register	0x210(L) / 0x213(B)
EP1_DMA_TTC_H	Endpoint1 DMA transfer counter high-byte register	0x214(L) / 0x217(B)
EP2_DMA_CON	Endpoint2 DMA control register	0x218(L) / 0x21B(B)

USB DEVICE CONTROLLER SPECIAL REGISTERS (Continued)

Register Name	Description	Offset Address
EP2_DMA_UNIT	Endpoint2 DMA unit counter register	0x21C(L) / 0x21F(B)
EP2_DMA_FIFO	Endpoint2 DMA FIFO counter register	0x220(L) / 0x223(B)
EP2_DMA_TTC_L	Endpoint2 DMA transfer counter low-byte register	0x224(L) / 0x227(B)
EP2_DMA_TTC_M	Endpoint2 DMA transfer counter middle-byte register	0x228(L) / 0x22B(B)
EP2_DMA_TTC_H	Endpoint2 DMA transfer counter high-byte register	0x22C(L) / 0x22F(B)
EP3_DMA_CON	Endpoint3 DMA control register	0x240(L) / 0x243(B)
EP3_DMA_UNIT	Endpoint3 DMA unit counter register	0x244(L) / 0x247(B)
EP3_DMA_FIFO	Endpoint3 DMA FIFO counter register	0x248(L) / 0x24B(B)
EP3_DMA_TTC_L	Endpoint3 DMA transfer counter low-byte register	0x24C(L) / 0x24F(B)
EP3_DMA_TTC_M	Endpoint3 DMA transfer counter middle-byte register	0x250(L) / 0x253(B)
EP3_DMA_TTC_H	Endpoint3 DMA transfer counter high-byte register	0x254(L) / 0x247(B)
EP4_DMA_CON	Endpoint4 DMA control register	0x258(L) / 0x25B(B)
EP4_DMA_UNIT	Endpoint4 DMA unit counter register	0x25C(L) / 0x25F(B)
EP4_DMA_FIFO	Endpoint4 DMA FIFO counter register	0x260(L) / 0x263(B)
EP4_DMA_TTC_L	Endpoint4 DMA transfer counter low-byte register	0x264(L) / 0x267(B)
EP4_DMA_TTC_M	Endpoint4 DMA transfer counter middle-byte register	0x268(L) / 0x26B(B)
EP4_DMA_TTC_H	Endpoint4 DMA transfer counter high-byte register	0x26C(L) / 0x26F(B)
Common Indexed Registers		
MAXP_REG	Endpoint MAX packet register	0x180(L) / 0x183(B)
In Indexed Registers		
IN_CSR1_REG/EP0_CSR	EP In control status register 1/EP0 control status register	0x184(L) / 0x187(B)
IN_CSR2_REG	EP In control status register 2	0x188(L) / 0x18B(B)
Out Indexed Registers		
OUT_CSR1_REG	EP out control status register 1	0x190(L) / 0x193(B)
OUT_CSR2_REG	EP out control status register 2	0x194(L) / 0x197(B)
OUT_FIFO_CNT1_REG	EP out write count register 1	0x198(L) / 0x19B(B)
OUT_FIFO_CNT2_REG	EP out write count register 2	0x19C(L) / 0x19F(B)

FUNCTION ADDRESS REGISTER (FUNC_ADDR_REG)

This register maintains the USB device controller address assigned by the host. The Micro Controller Unit (MCU) writes the value received through a SET_ADDRESS descriptor to this register. This address is used for the next token.

Register	Address	R/W	Description	Reset Value
FUNC_ADDR_REG	0x52000140(L) 0x52000143(B)	R/W (byte)	Function address register	0x00

FUNC_ADDR_REG	Bit	MCU	USB	Description	Initial State
ADDR_UPDATE	[7]	R /SET	R /CLEAR	Set by the MCU whenever it updates the FUNCTION_ADDR field in this register. This bit will be cleared by USB when DATA_END bit in EP0_CSR register.	0
FUNCTION_ADDR	[6:0]	R/W	R	The MCU write the unique address, assigned by host, to this field.	00

POWER MANAGEMENT REGISTER (PWR_REG)

This register acts as a power control register in the USB block.

Register	Address	R/W	Description	Reset Value
PWR_REG	0x52000144(L) 0x52000147(B)	R/W (byte)	Power management register	0x00

PWR_ADDR	Bit	MCU	USB	Description	Initial State
Reserved	[7:4]	–	–	–	–
USB_RESET	[3]	R	SET	Set by the USB if reset signaling is received from the host. This bit remains set as long as reset signaling persists on the bus	0
MCU_RESUME	[2]	R/W	R /CLEAR	Set by the MCU for MCU Resume. The USB generates the resume signaling during 10ms, if this bit is set in suspend mode.	
SUSPEND_MODE	[1]	R	SET /CLEAR	Set by USB automatically when the device enter into suspend mode. It is cleared under the following conditions: 1) The MCU clears the MCU_RESUME bit by writing '0', in order to end remote resume signaling. 2) The resume signal from host is received.	0
SUSPEND_EN	[0]	R/W	R	Suspend mode enable control bit 0 = Disable (default). The device will not enter suspend mode. 1 = Enable suspend mode	0

INTERRUPT REGISTER (EP_INT_REG/USB_INT_REG)

The USB core has two interrupt registers. These registers act as status registers for the MCU when it is interrupted. The bits are cleared by writing a '1' (not '0') to each bit that was set.

Once the MCU is interrupted, MCU should read the contents of interrupt-related registers and write back to clear the contents if it is necessary.

Register	Address	R/W	Description	Reset Value
EP_INT_REG	0x52000148(L) 0x5200014B(B)	R/W (byte)	EP interrupt pending/clear register	0x00

EP_INT_REG	Bit	MCU	USB	Description	Initial State
EP1~EP4 Interrupt	[4:1]	R /CLEAR	SET	For BULK/INTERRUPT IN endpoints: Set by the USB under the following conditions: 1. IN_PKT_RDY bit is cleared. 2. FIFO is flushed 3. SENT_STALL set. For BULK/INTERRUPT OUT endpoints: Set by the USB under the following conditions: 1. Sets OUT_PKT_RDY bit 2. Sets SENT_STALL bit	0
EPO Interrupt	[0]	R /CLEAR	SET	Correspond to endpoint 0 interrupt. Set by the USB under the following conditions: 1. OUT_PKT_RDY bit is set. 2. IN_PKT_RDY bit is cleared. 3. SENT_STALL bit is set 4. SETUP_END bit is set 5. DATA_END bit is cleared (it indicates the end of control transfer).	0

INTERRUPT REGISTER (EP_INT_REG/USB_INT_REG) (Continued)

Register	Address	R/W	Description	Reset Value
USB_INT_REG	0x52000158(L) 0x5200015B(B)	R/W (byte)	USB interrupt pending/clear register	0x00

USB_INT_REG	Bit	MCU	USB	Description	Initial State
RESET Interrupt	[2]	R /CLEAR	SET	Set by the USB when it receives reset signaling.	0
RESUME Interrupt	[1]	R /CLEAR	SET	Set by the USB when it receives resume signaling, while_in Suspend mode. If the resume occurs due to a USB reset, then the MCU is first interrupted with a RESUME interrupt. Once the clocks resume and the SE0 condition persists for 3ms, USB RESET interrupt will be asserted.	0
SUSPEND Interrupt	[0]	R /CLEAR	SET	Set by the USB when it receives suspend signaling. This bit is set whenever there is no activity for 3ms on the bus. Thus, if the MCU does not stop the clock after the first suspend interrupt, it will continue to be interrupted every 3ms as long as there is no activity on the USB bus. By default, this interrupt is disabled.	0

INTERRUPT ENABLE REGISTER (EP_INT_EN_REG/USB_INT_EN_REG)

Corresponding to each interrupt register, The USB device controller also has two interrupt enable registers (except resume interrupt enable). By default, usb reset interrupt is enabled.

If bit = 0, the interrupt is disabled.

If bit = 1, the interrupt is enabled.

Register	Address	R/W	Description	Reset Value
EP_INT_EN_REG	0x5200015C(L) 0x5200015F(B)	R/W (byte)	Determine which interrupt is enabled	0xFF

EP_INT_EN_REG	Bit	MCU	USB	Description	Initial State
EP4_INT_EN	[4]	R/W	R	EP4 Interrupt Enable bit 0 = Interrupt disable 1 = Enable	1
EP3_INT_EN	[3]	R/W	R	EP3 Interrupt Enable bit 0 = Interrupt disable 1 = Enable	1
EP2_INT_EN	[2]	R/W	R	EP2 Interrupt Enable bit 0 = Interrupt disable 1 = Enable	1
EP1_INT_EN	[1]	R/W	R	EP1 Interrupt Enable bit 0 = Interrupt disable 1 = Enable	1
EP0_INT_EN	[0]	R/W	R	EP0 Interrupt Enable bit 0 = Interrupt disable 1 = Enable	1

Register	Address	R/W	Description	Reset Value
USB_INT_EN_REG	0x520016C(L) 0x5200016F(B)	R/W (byte)	Determine which interrupt is enabled	0x04

INT_MASK_REG	Bit	MCU	USB	Description	Initial State
RESET_INT_EN	[2]	R/W	R	Reset interrupt enable bit 0 = Interrupt disable 1 = Enable	1
Reserved	[1]	–	–	–	0
SUSPEND_INT_EN	[0]	R/W	R	Suspend interrupt enable bit 0 = Interrupt disable 1 = Enable	0

FRAME NUMBER REGISTER (FRAME_NUM1_REG/FRAME_NUM2_REG)

When the host transfers USB packets, each **Start Of Frame** (SOF) packet includes a frame number. The USB device controller catches this frame number and loads it into this register automatically.

Register	Address	R/W	Description	Reset Value
FRAME_NUM1_REG	0x52000170(L) 0x52000173(B)	R (byte)	Frame number lower byte register	0x00

FRAME_NUM_REG	Bit	MCU	USB	Description	Initial State
FRAME_NUM1	[7:0]	R	W	Frame number lower byte value	00

Register	Address	R/W	Description	Reset Value
FRAME_NUM2_REG	0x52000174(L) 0x52000177(B)	R (byte)	Frame number higher byte register	0x00

FRAME_NUM_REG	Bit	MCU	USB	Description	Initial State
FRAME_NUM2	[7:0]	R	W	Frame number higher byte value	00

INDEX REGISTER (INDEX_REG)

The INDEX register is used to indicate certain endpoint registers effectively. The MCU can access the endpoint registers (MAXP_REG, IN_CSR1_REG, IN_CSR2_REG, OUT_CSR1_REG, OUT_CSR2_REG, OUT_FIFO_CNT1_REG, and OUT_FIFO_CNT2_REG) for an endpoint inside the core using the INDEX register.

Register	Address	R/W	Description	Reset Value
INDEX_REG	0x52000178(L) 0x5200017B(B)	R/W (byte)	Register index register	0x00

INDEX_REG	Bit	MCU	USB	Description	Initial State
INDEX	[7:0]	R/W	R	Indicate a certain endpoint	00

MAX PACKET REGISTER (MAXP_REG)

Register	Address	R/W	Description	Reset Value
MAXP_REG	0x52000180(L) 0x52000183(B)	R/W (byte)	End Point MAX packet register	0x01

MAXP_REG	Bit	MCU	USB	Description	Initial State
MAXP	[3:0]	R/W	R	0000: Reserved 0001: MAXP = 8 Byte 0010: MAXP = 16 Byte 0100: MAXP = 32 Byte 1000: MAXP = 64 Byte For EP0, MAXP=8 is recommended. For EP1~4, MAXP=64 is recommended. And, if MAXP=64, the dual packet mode will be enabled automatically.	0001

END POINT0 CONTROL STATUS REGISTER (EP0_CSR)

This register has the control and status bits for Endpoint 0. Since a control transaction is involved with both IN and OUT tokens, there is only one CSR register, mapped to the IN CSR1 register. (Share IN1_CSR and can access by writing index register "0" and read/write IN1_CSR)

Register	Address	R/W	Description	Reset Value
EP0_CSR	0x52000184(L) 0x52000187(B)	R/W (byte)	Endpoint 0 status register	0x00

EP0_CSR	Bit	MCU	USB	Description	Initial State
SERVICED_SETUP_END	[7]	W	CLEAR	The MCU should write a "1" to this bit to clear SETUP_END.	0
SERVICED_OUT_PKT_RDY	[6]	W	CLEAR	The MCU should write a "1" to this bit to clear OUT_PKT_RDY.	0
SEND_STALL	[5]	R/W	CLEAR	MCU should write a "1" to this bit at the same time it clears OUT_PKT_RDY, if it decodes an invalid token. 0 = Finish the STALL condition 1 = The USB issues a STALL and shake to the current control transfer.	0
SETUP_END	[4]	R	SET	Set by the USB when a control transfer ends before DATA_END is set. When the USB sets this bit, an interrupt is generated to the MCU. When such a condition occurs, the USB flushes the FIFO and invalidates MCU access to the FIFO.	0
DATA_END	[3]	SET	CLEAR	Set by the MCU on the conditions below: 1. After loading the last packet of data into the FIFO, at the same time IN_PKT_RDY is set. 2. While it clears OUT_PKT_RDY after unloading the last packet of data. 3. For a zero length data phase.	0
SENT_STALL	[2]	CLEAR	SET	Set by the USB if a control transaction is stopped due to a protocol violation. An interrupt is generated when this bit is set. The MCU should write "0" to clear this bit.	0
IN_PKT_RDY	[1]	SET	CLEAR	Set by the MCU after writing a packet of data into EP0 FIFO. The USB clears this bit once the packet has been successfully sent to the host. An interrupt is generated when the USB clears this bit, so as the MCU to load the next packet. For a zero length data phase, the MCU sets DATA_END at the same time.	0
OUT_PKT_RDY	[0]	R	SET	Set by the USB once a valid token is written to the FIFO. An interrupt is generated when the USB sets this bit. The MCU clears this bit by writing a "1" to the SERVICED_OUT_PKT_RDY bit.	0

END POINT IN CONTROL STATUS REGISTER (IN_CSR1_REG/IN_CSR2_REG)

Register	Address	R/W	Description	Reset Value
IN_CSR1_REG	0x52000184(L) 0x52000187(B)	R/W (byte)	IN END POINT control status register1	0x00

IN_CSR1_REG	Bit	MCU	USB	Description	Initial State
Reserved	[7]	–	–	–	–
CLR_DATA_TOGGLE	[6]	R/W	R/ CLEAR	Used in set-up procedure. 0: There are alternation of DATA0 and DATA1 1: The data toggle bit is cleared and PID in packet will maintain DATA0	0
SENT_STALL	[5]	R/ CLEAR	SET	Set by the USB when an IN token issues a STALL handshake, after the MCU sets SEND_STALL bit to start STALL handshaking. When the USB issues a STALL handshake, IN_PKT_RDY is cleared	0
SEND_STALL	[4]	W/R	R	0: The MCU clears this bit to finish the STALL condition. 1: The MCU issues a STALL handshake to the USB.	0
FIFO_FLUSH	[3]	R/W	CLEAR	Set by the MCU if it intends to flush the packet in Input-related FIFO. This bit is cleared by the USB when the FIFO is flushed. The MCU is interrupted when this happens. If a token is in process, the USB waits until the transmission is complete before FIFO flushing. If two packets are loaded into the FIFO, only first packet (The packet is intended to be sent to the host) is flushed, and the corresponding IN_PKT_RDY bit is cleared	0
Reserved	[2:1]	–	–	–	–
IN_PKT_RDY	[0]	R/SET	CLEAR	Set by the MCU after writing a packet of data into the FIFO. The USB clears this bit once the packet has been successfully sent to the host. An interrupt is generated when the USB clears this bit, so the MCU can load the next packet. While this bit is set, the MCU will not be able to write to the FIFO. If the MCU sets SEND STALL bit, this bit cannot be set.	0

END POINT IN CONTROL STATUS REGISTER (IN_CSR1_REG/IN_CSR2_REG) (Continued)

Register	Address	R/W	Description	Reset Value
IN_CSR2_REG	0x52000188(L) 0x5200018B(B)	R/W (byte)	IN END POINT control status register2	0x20

IN_CSR2_REG	Bit	MCU	USB	Description	Initial State
AUTO_SET	[7]	R/W	R	If set, whenever the MCU writes MAXP data, IN_PKT_RDY will automatically be set by the core without any intervention from MCU. If the MCU writes less than MAXP data, IN_PKT_RDY bit has to be set by the MCU.	0
ISO	[6]	R/W	R	Used only for endpoints whose transfer type is programmable. 1: Reserved 0: Configures endpoint to Bulk mode	0
MODE_IN	[5]	R/W	R	Used only for endpoints whose direction is programmable. 1: Configures Endpoint Direction as IN 0: Configures Endpoint Direction as OUT	1
IN_DMA_INT_EN	[4]	R/W	R	Determine whether the interrupt should be issued or not, when the IN_PKT_RDY condition happens. This is only useful for DMA mode. 0 = Interrupt enable, 1 = Interrupt Disable	0
Reserved	[3:0]	–	–	–	–

END POINT OUT CONTROL STATUS REGISTER (OUT_CSR1_REG/OUT_CSR2_REG)

Register	Address	R/W	Description	Reset Value
OUT_CSR1_REG	0x52000190(L) 0x52000193(B)	R/W (byte)	End point out control status register1	0x00

OUT_CSR1_REG	Bit	MCU	USB	Description	Initial State
CLR_DATA_TOGGLE	[7]	R/W	CLEAR	When the MCU writes a 1 to this bit, the data toggle sequence bit is reset to DATA0.	0
SENT_STALL	[6]	CLEAR /R	SET	Set by the USB when an OUT token is ended with a STALL handshake. The USB issues a stall handshake to the host if it sends more than MAXP data for the OUT TOKEN.	0
SEND_STALL	[5]	R/W	R	0: The MCU clears this bit to end the STALL condition handshake, IN PKT RDY is cleared. 1: The MCU issues a STALL handshake to the USB. The MCU clears this bit to end the STALL condition handshake, IN PKT RDY is cleared.	0
FIFO_FLUSH	[4]	R/W	CLEAR	The MCU writes a 1 to flush the FIFO. This bit can be set only when OUT_PKT_RDY (D0) is set. The packet due to be unloaded by the MCU will be flushed.	0
Reserved	[3:1]	–	–	–	0
OUT_PKT_RDY	[0]	R/ CLEAR	SET	Set by the USB after it has loaded a packet of data into the FIFO. Once the MCU reads the packet from FIFO, this bit should be cleared by MCU (write a "0").	0

END POINT OUT CONTROL STATUS REGISTER (OUT_CSR1_REG/OUT_CSR2_REG) (Continued)

Register	Address	R/W	Description	Reset Value
OUT_CSR2_REG	0x52000194(L) 0x52000197(B)	R/W (byte)	End point out control status register2	0x00

OUT_CSR2_REG	Bit	MCU	USB	Description	Initial State
AUTO_CLR	[7]	R/W	R	If the MCU is set, whenever the MCU reads data from the OUT FIFO, OUT_PKT_RDY will automatically be cleared by the logic without any intervention from the MCU.	0
ISO	[6]	R/W	R	Determine endpoint transfer type. 0: Configures endpoint to Bulk mode. 1: Reserved.	0
OUT_DMA_INT_MASK	[5]	R/W	R	Determine whether the interrupt should be issued or not. OUT_PKT_RDY condition happens. This is only useful for DMA mode 0 = Interrupt Enable 1 = Interrupt Disable	0

END POINT OUT WRITE COUNT REGISTER (OUT_FIFO_CNT1_REG/OUT_FIFO_CNT2_REG)

These registers maintain the number of bytes in the packet as the number is unloaded by the MCU.

Register	Address	R/W	Description	Reset Value
OUT_FIFO_CNT1_REG	0x52000198(L) 0x5200019B(B)	R (byte)	End point out write count register1	0x00

OUT_FIFO_CNT1_REG	Bit	MCU	USB	Description	Initial State
OUT_CNT_LOW	[7:0]	R	W	Lower byte of write count	0x00

Register	Address	R/W	Description	Reset Value
OUT_FIFO_CNT2_REG	0x5200019C(L) 0x5200019F(B)	R (byte)	End point out write count register2	0x00

OUT_FIFO_CNT2_REG	Bit	MCU	USB	Description	Initial State
OUT_CNT_HIGH	[7:0]	R	W	Higher byte of write count. The OUT_CNT_HIGH may be always 0 normally.	0x00

END POINT FIFO REGISTER (EPn_FIFO_REG)

The EPn_FIFO_REG enables the MCU to access to the EPn FIFO.

Register	Address	R/W	Description	Reset Value
EP0_FIFO	0x520001C0(L) 0x520001C3 (B)	R/W (byte)	End point0 FIFO register	0xFF
EP1_FIFO	0x520001C4(L) 0x520001C7(B)	R/W (byte)	End point1 FIFO register	0xFF
EP2_FIFO	0x520001C8(L) 0x520001CB(B)	R/W (byte)	End point2 FIFO register	0xFF
EP3_FIFO	0x520001CC(L) 0x520001CF(B)	R/W (byte)	End point3 FIFO register	0xFF
EP4_FIFO	0x520001D0(L) 0x520001D3(B)	R/W (byte)	End point4 FIFO register	0xFF

EPn_FIFO	Bit	MCU	USB	Description	Initial State
FIFO_DATA	[7:0]	R/W	R/W	FIFO data value	0xFF

DMA INTERFACE CONTROL REGISTER (EPn_DMA_CON)

Register	Address	R/W	Description	Reset Value
EP1_DMA_CON	0x52000200(L) 0x52000203(B)	R/W (byte)	EP1 DMA interface control register	0x00
EP2_DMA_CON	0x52000218(L) 0x5200021B(B)	R/W (byte)	EP2 DMA interface control register	0x00
EP3_DMA_CON	0x52000240(L) 0x52000243(B)	R/W (byte)	EP3 DMA interface control register	0x00
EP4_DMA_CON	0x52000258(L) 0x5200025B(B)	R/W (byte)	EP4 DMA interface control register	0x00

EPn_DMA_CON	Bit	MCU	USB	Description	Initial State
RUN_OB	[7]	R/W	W	Read) DMA run observation 0: DMA is stopped 1:DMA is running Write) Ignore EPn_DMA_TTC_n register 0: DMA requests will be stopped if EPn_DMA_TTC_n reaches 0. 1: DMA requests will be continued although EPn_DMA_TTC_n reaches 0.	0
STATE	[6:4]	R	W	DMA state monitoring	0
DEMAND_MODE	[3]	R/W	R	DMA demand mode enable bit 0: Demand mode disable 1: Demand mode enable	0
OUT_RUN_OB / OUT_DMA_RUN	[2]	R/W	R/W	Functionally separated into write and read operation. Write operation: '0' = Stop '1' = Run Read operation: OUT DMA Run Observation	0
IN_DMA_RUN	[1]	R/W	R	Start DMA operation. 0 = Stop 1 = Run	0
DMA_MODE_EN	[0]	R/W	R/Clear	Set DMA mode.If the RUN_OB has been wrtten as 0 and EPn_DMA_TTC_n reaches 0, DMA_MODE_EN bit will be cleared by USB. 0 = Interrupt Mode 1 = DMA Mode	0

DMA UNIT COUNTER REGISTER (EPN_DMA_UNIT)

This register is valid in Demand mode. In other modes, this register value must be set to '0x01'

Register	Address	R/W	Description	Reset Value
EP1_DMA_UNIT	0x52000204(L) 0x52000207(B)	R/W (byte)	EP1 DMA transfer unit counter base register	0x00
EP2_DMA_UNIT	0x5200021C(L) 0x5200021F(B)	R/W (byte)	EP2 DMA transfer unit counter base register	0x00
EP3_DMA_UNIT	0x52000244(L) 0x52000247(B)	R/W (byte)	EP3 DMA transfer unit counter base register	0x00
EP4_DMA_UNIT	0x5200025C(L) 0x5200025F(B)	R/W (byte)	EP4 DMA transfer unit counter base register	0x00

DMA_UNIT	Bit	MCU	USB	Description	Initial State
EPn_UNIT_CNT	[7:0]	R/W	R	EP DMA transfer unit counter value	0x00

DMA FIFO COUNTER REGISTER (EPN_DMA_FIFO)

This register has values in byte size in FIFO to be transferred by DMA. In case of OUT_DMA_RUN enabled, the value in OUT FIFO Write Count Register1 will be loaded in this register automatically. In case of IN DMA mode, the MCU should set proper value by software.

Register	Address	R/W	Description	Reset Value
EP1_DMA_FIFO	0x52000208(L) 0x5200020B(B)	R/W (byte)	EP1 DMA transfer FIFO counter base register	0x00
EP2_DMA_FIFO	0x52000220(L) 0x52000223(B)	R/W (byte)	EP2 DMA transfer FIFO counter base register	0x00
EP3_DMA_FIFO	0x52000248(L) 0x5200024B(B)	R/W (byte)	EP3 DMA transfer FIFO counter base register	0x00
EP4_DMA_FIFO	0x52000260(L) 0x52000263(B)	R/W (byte)	EP4 DMA transfer FIFO counter base register	0x00

DMA_FIFO	Bit	MCU	USB	Description	Initial State
EPn_FIFO_CNT	[7:0]	R/W	R	EP DMA transfer FIFO counter value	0x00

DMA TOTAL TRANSFER COUNTER REGISTER (EPn_DMA_TTC_L,M,H)

This register should have total number of bytes to be transferred using DMA (total 20-bit counter).

Register	Address	R/W	Description	Reset Value
EP1_DMA_TTC_L	0x5200020C(L) 0x5200020F(B)	R/W (byte)	EP1 DMA total transfer counter (lower byte)	0x00
EP1_DMA_TTC_M	0x52000210(L) 0x52000213(B)	R/W (byte)	EP1 DMA total transfer counter (middle byte)	0x00
EP1_DMA_TTC_H	0x52000214(L) 0x52000217(B)	R/W (byte)	EP1 DMA total transfer counter (higher byte)	0x00
EP2_DMA_TTC_L	0x52000224(L) 0x52000227(B)	R/W (byte)	EP2 DMA total transfer counter (lower byte)	0x00
EP2_DMA_TTC_M	0x52000228(L) 0x5200022B(B)	R/W (byte)	EP2 DMA total transfer counter (middle byte)	0x00
EP2_DMA_TTC_H	0x5200022C(L) 0x5200022F(B)	R/W (byte)	EP2 DMA total transfer counter (higher byte)	0x00
EP3_DMA_TTC_L	0x5200024C(L) 0x5200024F(B)	R/W (byte)	EP3 DMA total transfer counter (lower byte)	0x00
EP3_DMA_TTC_M	0x52000250(L) 0x52000253(B)	R/W (byte)	EP3 DMA total transfer counter (middle byte)	0x00
EP3_DMA_TTC_H	0x52000254(L) 0x52000257(B)	R/W (byte)	EP3 DMA total transfer counter (higher byte)	0x00
EP4_DMA_TTC_L	0x52000264(L) 0x52000267(B)	R/W (byte)	EP4 DMA total transfer counter (lower byte)	0x00
EP4_DMA_TTC_M	0x52000268(L) 0x5200026B(B)	R/W (byte)	EP4 DMA total transfer counter (middle byte)	0x00
EP4_DMA_TTC_H	0x5200026C(L) 0x5200026F(B)	R/W (byte)	EP4 DMA total transfer counter (higher byte)	0x00

DMA_TX	Bit	MCU	USB	Description	Initial State
EPn_TTC_L	[7:0]	R/W	R	DMA total transfer count value (lower byte)	0x00
EPn_TTC_M	[7:0]	R/W	R	DMA total transfer count value (middle byte)	0x00
EPn_TTC_H	[3:0]	R/W	R	DMA total transfer count value (higher byte)	0x00

NOTES

14 INTERRUPT CONTROLLER

OVERVIEW

The interrupt controller in the S3C2440A receives the request from 60 interrupt sources. These interrupt sources are provided by internal peripherals such as DMA controller, UART, IIC, and others. In these interrupt sources, the UARTn, AC97 and EINTn interrupts are 'OR'ed to the interrupt controller.

When receiving multiple interrupt requests from internal peripherals and external interrupt request pins, the interrupt controller requests FIQ or IRQ interrupt of the ARM920T core after the arbitration procedure.

The arbitration procedure depends on the hardware priority logic and the result is written to the interrupt pending register, which helps users notify which interrupt is generated out of various interrupt sources.

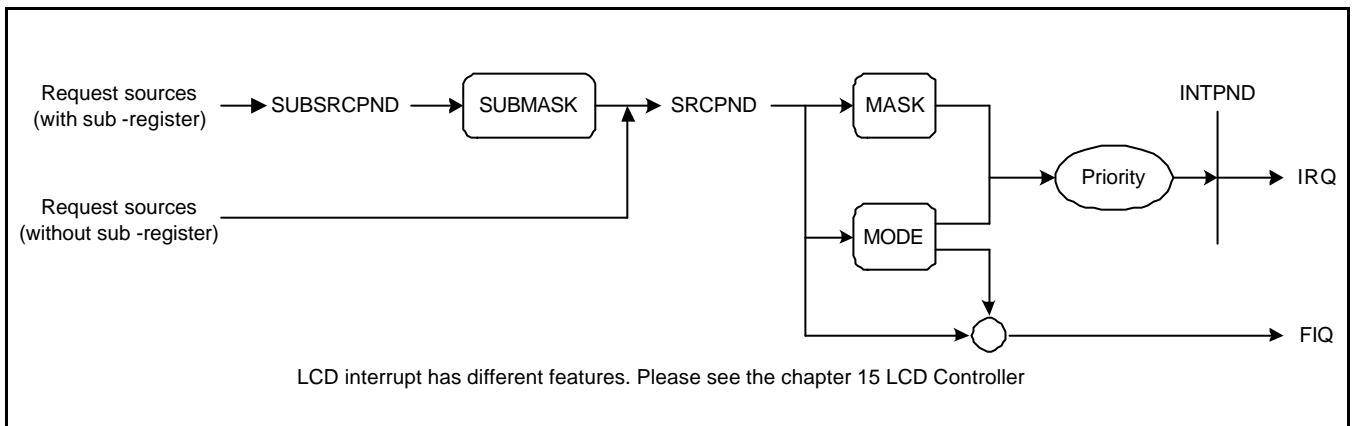

Figure 14-1. Interrupt Process Diagram

INTERRUPT CONTROLLER OPERATION

F-bit and I-bit of Program Status Register (PSR)

If the F-bit of PSR in ARM920T CPU is set to 1, the CPU does not accept the Fast Interrupt Request (FIQ) from the interrupt controller. Likewise, If I-bit of the PSR is set to 1, the CPU does not accept the Interrupt Request (IRQ) from the interrupt controller. So, the interrupt controller can receive interrupts by clearing F-bit or I-bit of the PSR to 0 and setting the corresponding bit of INTMSK to 0.

Interrupt Mode

The ARM920T has two types of Interrupt mode: FIQ or IRQ. All the interrupt sources determine which mode is used at interrupt request.

Interrupt Pending Register

The S3C2440A has two interrupt pending registers: source pending register (SRCPND) and interrupt pending register (INTPND). These pending registers indicate whether an interrupt request is pending or not. When the interrupt sources request interrupt the service, the corresponding bits of SRCPND register are set to 1, and at the same time, only one bit of the INTPND register is set to 1 automatically after arbitration procedure. If interrupts are masked, then the corresponding bits of the SRCPND register are set to 1. This does not cause the bit of INTPND register changed. When a pending bit of INTPND register is set, the interrupt service routine will start whenever the I-flag or F-flag is cleared to 0. The SRCPND and INTPND registers can be read and written, so the service routine must clear the pending condition by writing a 1 to the corresponding bit in the SRCPND register first and then clear the pending condition in the INTPND registers by using the same method.

Interrupt Mask Register

This register indicates that an interrupt has been disabled if the corresponding mask bit is set to 1. If an interrupt mask bit of INTMSK is 0, the interrupt will be serviced normally. If the corresponding mask bit is 1 and the interrupt is generated, the source pending bit will be set.

INTERRUPT SOURCES

The interrupt controller supports 60 interrupt sources as shown in the table below.

Sources	Descriptions	Arbiter Group
INT_ADC	ADC EOC and Touch interrupt (INT_ADC_S/INT_TC)	ARB5
INT_RTC	RTC alarm interrupt	ARB5
INT_SPI1	SPI1 interrupt	ARB5
INT_UART0	UART0 Interrupt (ERR, RXD, and TXD)	ARB5
INT_IIC	IIC interrupt	ARB4
INT_USBH	USB Host interrupt	ARB4
INT_USBD	USB Device interrupt	ARB4
INT_NFCON	Nand Flash Control Interrupt	ARB4
INT_UART1	UART1 Interrupt (ERR, RXD, and TXD)	ARB4
INT_SPI0	SPI0 interrupt	ARB4
INT_SDI	SDI interrupt	ARB 3
INT_DMA3	DMA channel 3 interrupt	ARB3
INT_DMA2	DMA channel 2 interrupt	ARB3
INT_DMA1	DMA channel 1 interrupt	ARB3
INT_DMA0	DMA channel 0 interrupt	ARB3
INT_LCD	LCD interrupt (INT_FrSyn and INT_FiCnt)	ARB3
INT_UART2	UART2 Interrupt (ERR, RXD, and TXD)	ARB2
INT_TIMER4	Timer4 interrupt	ARB2
INT_TIMER3	Timer3 interrupt	ARB2
INT_TIMER2	Timer2 interrupt	ARB2
INT_TIMER1	Timer1 interrupt	ARB 2
INT_TIMER0	Timer0 interrupt	ARB2
INT_WDT_AC97	Watch-Dog timer interrupt(INT_WDT, INT_AC97)	ARB1
INT_TICK	RTC Time tick interrupt	ARB1
nBATT_FLT	Battery Fault interrupt	ARB1
INT_CAM	Camera Interface (INT_CAM_C, INT_CAM_P)	ARB1
EINT8_23	External interrupt 8 – 23	ARB1
EINT4_7	External interrupt 4 – 7	ARB1
EINT3	External interrupt 3	ARB0
EINT2	External interrupt 2	ARB0
EINT1	External interrupt 1	ARB0
EINT0	External interrupt 0	ARB0

INTERRUPT SUB SOURCES

Sub Sources	Descriptions	Source
INT_AC97	AC97 interrupt	INT_WDT_AC97
INT_WDT	Watchdog interrupt	INT_WDT_AC97
INT_CAM_P	P-port capture interrupt in camera interface	INT_CAM
INT_CAM_C	C-port capture interrupt in camera interface	INT_CAM
INT_ADC_S	ADC interrupt	INT_ADC
INT_TC	Touch screen interrupt (pen up/down)	INT_ADC
INT_ERR2	UART2 error interrupt	INT_UART2
INT_TXD2	UART2 transmit interrupt	INT_UART2
INT_RXD2	UART2 receive interrupt	INT_UART2
INT_ERR1	UART1 error interrupt	INT_UART1
INT_TXD1	UART1 transmit interrupt	INT_UART1
INT_RXD1	UART1 receive interrupt	INT_UART1
INT_ERR0	UART0 error interrupt	INT_UART0
INT_TXD0	UART0 transmit interrupt	INT_UART0
INT_RXD0	UART0 receive interrupt	INT_UART0

INTERRUPT PRIORITY GENERATING BLOCK

The priority logic for 32 interrupt requests is composed of seven rotation based arbiters: six first-level arbiters and one second-level arbiter as shown in Figure 14-1 below.

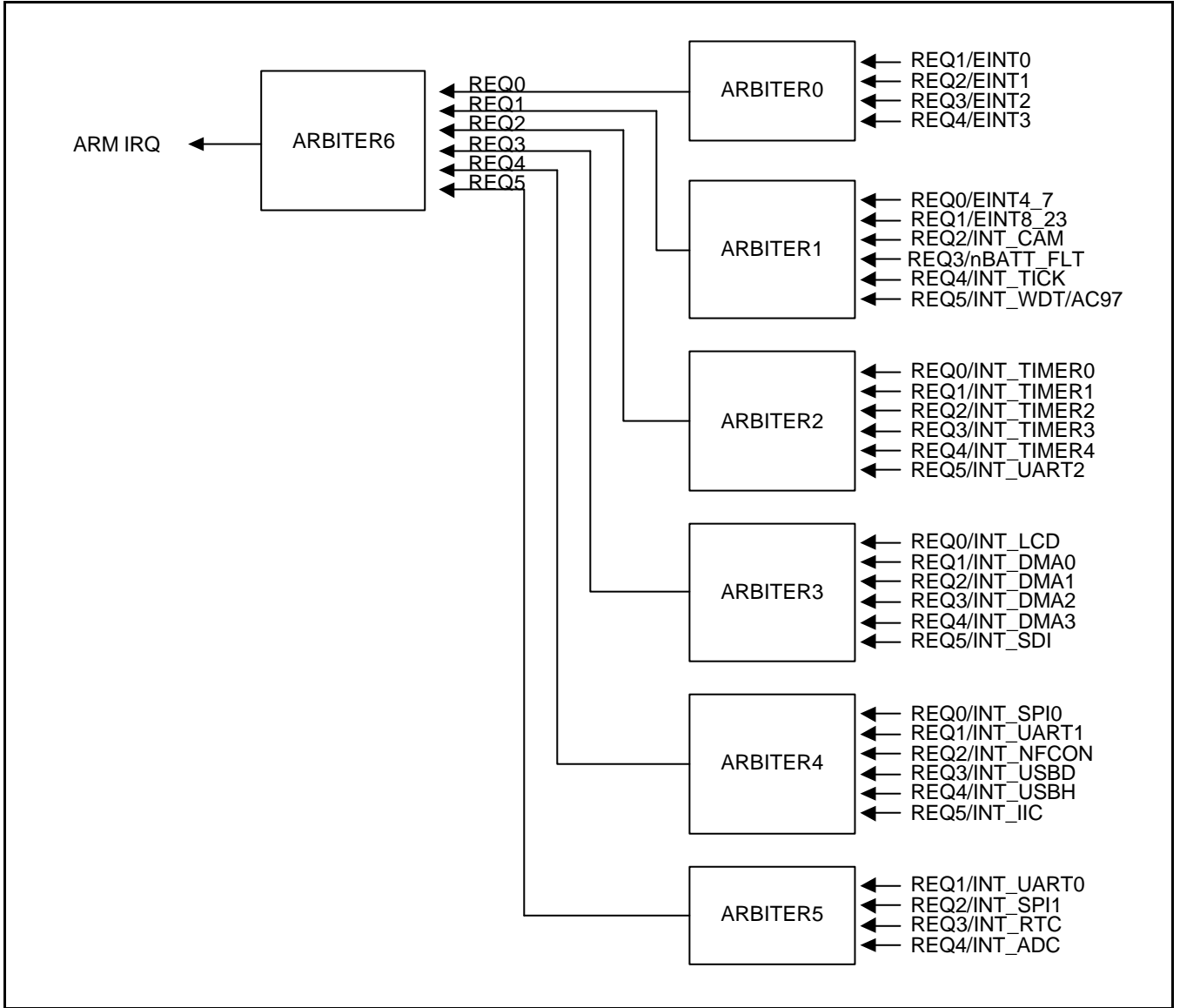

Figure 14-2. Priority Generating Block

INTERRUPT PRIORITY

Each arbiter can handle six interrupt requests based on the one bit arbiter mode control (ARB_MODE) and two bits of selection control signals (ARB_SEL) as follows:

- If ARB_SEL bits are 00b, the priority order is REQ0, REQ1, REQ2, REQ3, REQ4, and REQ5.
- If ARB_SEL bits are 01b, the priority order is REQ0, REQ2, REQ3, REQ4, REQ1, and REQ5.
- If ARB_SEL bits are 10b, the priority order is REQ0, REQ3, REQ4, REQ1, REQ2, and REQ5.
- If ARB_SEL bits are 11b, the priority order is REQ0, REQ4, REQ1, REQ2, REQ3, and REQ5.

Note that REQ0 of an arbiter always has the highest priority, and REQ5 has the lowest one. In addition, by changing the ARB_SEL bits, we can rotate the priority of REQ1 to REQ4.

Here, if ARB_MODE bit is set to 0, ARB_SEL bits doesn't change automatically changed, making the arbiter to operate in the fixed priority mode (note that even in this mode, we can reconfigure the priority by manually changing the ARB_SEL bits). On the other hand, if ARB_MODE bit is 1, ARB_SEL bits are changed in rotation fashion, e.g., if REQ1 is serviced, ARB_SEL bits are changed to 01b automatically so as to put REQ1 into the lowest priority. The detailed rules of ARB_SEL change are as follows:

- If REQ0 or REQ5 is serviced, ARB_SEL bits are not changed at all.
- If REQ1 is serviced, ARB_SEL bits are changed to 01b.
- If REQ2 is serviced, ARB_SEL bits are changed to 10b.
- If REQ3 is serviced, ARB_SEL bits are changed to 11b.
- If REQ4 is serviced, ARB_SEL bits are changed to 00b.

INTERRUPT CONTROLLER SPECIAL REGISTERS

There are five control registers in the interrupt controller: source pending register, interrupt mode register, mask register, priority register, and interrupt pending register.

All the interrupt requests from the interrupt sources are first registered in the source pending register. They are divided into two groups including Fast Interrupt Request (FIQ) and Interrupt Request (IRQ), based on the interrupt mode register. The arbitration procedure for multiple IRQs is based on the priority register.

SOURCE PENDING (SRCPND) REGISTER

The SRCPND register is composed of 32 bits each of which is related to an interrupt source. Each bit is set to 1 if the corresponding interrupt source generates the interrupt request and waits for the interrupt to be serviced. Accordingly, this register indicates which interrupt source is waiting for the request to be serviced. Note that each bit of the SRCPND register is automatically set by the interrupt sources regardless of the masking bits in the INTMASK register. In addition, the SRCPND register is not affected by the priority logic of interrupt controller.

In the interrupt service routine for a specific interrupt source, the corresponding bit of the SRCPND register has to be cleared to get the interrupt request from the same source correctly. If you return from the ISR without clearing the bit, the interrupt controller operates as if another interrupt request came in from the same source. In other words, if a specific bit of the SRCPND register is set to 1, it is always considered as a valid interrupt request waiting to be serviced.

The time to clear the corresponding bit depends on the user's requirement. If you want to receive another valid request from the same source, you should clear the corresponding bit first, and then enable the interrupt.

You can clear a specific bit of the SRCPND register by writing a data to this register. It clears only the bit positions of the SRCPND corresponding to those set to one in the data. The bit positions corresponding to those that are set to 0 in the data remains as they are.

Register	Address	R/W	Description	Reset Value
SRCPND	0X4A000000	R/W	Indicate the interrupt request status. 0 = The interrupt has not been requested. 1 = The interrupt source has asserted the interrupt request.	0x00000000

SOURCE PENDING (SRCPND) REGISTER (Continued)

SRCPND	Bit	Description	Initial State
INT_ADC	[31]	0 = Not requested, 1 = Requested	0
INT_RTC	[30]	0 = Not requested, 1 = Requested	0
INT_SPI1	[29]	0 = Not requested, 1 = Requested	0
INT_UART0	[28]	0 = Not requested, 1 = Requested	0
INT_IIC	[27]	0 = Not requested, 1 = Requested	0
INT_USBH	[26]	0 = Not requested, 1 = Requested	0
INT_USBD	[25]	0 = Not requested, 1 = Requested	0
INT_NFCON	[24]	0 = Not requested, 1 = Requested	0
INT_UART1	[23]	0 = Not requested, 1 = Requested	0
INT_SPI0	[22]	0 = Not requested, 1 = Requested	0
INT_SDI	[21]	0 = Not requested, 1 = Requested	0
INT_DMA3	[20]	0 = Not requested, 1 = Requested	0
INT_DMA2	[19]	0 = Not requested, 1 = Requested	0
INT_DMA1	[18]	0 = Not requested, 1 = Requested	0
INT_DMA0	[17]	0 = Not requested, 1 = Requested	0
INT_LCD	[16]	0 = Not requested, 1 = Requested	0
INT_UART2	[15]	0 = Not requested, 1 = Requested	0
INT_TIMER4	[14]	0 = Not requested, 1 = Requested	0
INT_TIMER3	[13]	0 = Not requested, 1 = Requested	0
INT_TIMER2	[12]	0 = Not requested, 1 = Requested	0
INT_TIMER1	[11]	0 = Not requested, 1 = Requested	0
INT_TIMER0	[10]	0 = Not requested, 1 = Requested	0
INT_WDT_AC97	[9]	0 = Not requested, 1 = Requested	0
INT_TICK	[8]	0 = Not requested, 1 = Requested	0
nBATT_FLT	[7]	0 = Not requested, 1 = Requested	0
INT_CAM	[6]	0 = Not requested, 1 = Requested	0
EINT8_23	[5]	0 = Not requested, 1 = Requested	0
EINT4_7	[4]	0 = Not requested, 1 = Requested	0
EINT3	[3]	0 = Not requested, 1 = Requested	0
EINT2	[2]	0 = Not requested, 1 = Requested	0
EINT1	[1]	0 = Not requested, 1 = Requested	0
EINT0	[0]	0 = Not requested, 1 = Requested	0

INTERRUPT MODE (INTMOD) REGISTER

This register is composed of 32 bits each of which is related to an interrupt source. If a specific bit is set to 1, the corresponding interrupt is processed in the FIQ (fast interrupt) mode. Otherwise, it is processed in the IRQ mode (normal interrupt).

Please note that only one interrupt source can be serviced in the FIQ mode in the interrupt controller (you should use the FIQ mode only for the urgent interrupt). Thus, only one bit of INTMOD can be set to 1.

Register	Address	R/W	Description	Reset Value
INTMOD	0X4A000004	R/W	Interrupt mode register. 0 = IRQ mode 1 = FIQ mode	0x00000000

NOTE: If an interrupt mode is set to FIQ mode in the INTMOD register, FIQ interrupt will not affect both INTPND and INTOFFSET registers. In this case, the two registers are valid only for IRQ mode interrupt source.

INTERRUPT MODE (INTMOD) REGISTER (Continued)

INTMOD	Bit	Description	Initial State
INT_ADC	[31]	0 = IRQ, 1 = FIQ	0
INT_RTC	[30]	0 = IRQ, 1 = FIQ	0
INT_SPI1	[29]	0 = IRQ, 1 = FIQ	0
INT_UART0	[28]	0 = IRQ, 1 = FIQ	0
INT_IIC	[27]	0 = IRQ, 1 = FIQ	0
INT_USBH	[26]	0 = IRQ, 1 = FIQ	0
INT_USBD	[25]	0 = IRQ, 1 = FIQ	0
INT_NFCON	[24]	0 = IRQ, 1 = FIQ	0
INT_URRT1	[23]	0 = IRQ, 1 = FIQ	0
INT_SPI0	[22]	0 = IRQ, 1 = FIQ	0
INT_SDI	[21]	0 = IRQ, 1 = FIQ	0
INT_DMA3	[20]	0 = IRQ, 1 = FIQ	0
INT_DMA2	[19]	0 = IRQ, 1 = FIQ	0
INT_DMA1	[18]	0 = IRQ, 1 = FIQ	0
INT_DMA0	[17]	0 = IRQ, 1 = FIQ	0
INT_LCD	[16]	0 = IRQ, 1 = FIQ	0
INT_UART2	[15]	0 = IRQ, 1 = FIQ	0
INT_TIMER4	[14]	0 = IRQ, 1 = FIQ	0
INT_TIMER3	[13]	0 = IRQ, 1 = FIQ	0
INT_TIMER2	[12]	0 = IRQ, 1 = FIQ	0
INT_TIMER1	[11]	0 = IRQ, 1 = FIQ	0
INT_TIMER0	[10]	0 = IRQ, 1 = FIQ	0
INT_WDT_AC97	[9]	0 = IRQ, 1 = FIQ	0
INT_TICK	[8]	0 = IRQ, 1 = FIQ	0
nBATT_FLT	[7]	0 = IRQ, 1 = FIQ	0
INT_CAM	[6]	0 = IRQ, 1 = FIQ	0
EINT8_23	[5]	0 = IRQ, 1 = FIQ	0
EINT4_7	[4]	0 = IRQ, 1 = FIQ	0
EINT3	[3]	0 = IRQ, 1 = FIQ	0
EINT2	[2]	0 = IRQ, 1 = FIQ	0
EINT1	[1]	0 = IRQ, 1 = FIQ	0
EINT0	[0]	0 = IRQ, 1 = FIQ	0

INTERRUPT MASK (INTMSK) REGISTER

This register also has 32 bits each of which is related to an interrupt source. If a specific bit is set to 1, the CPU does not service the interrupt request from the corresponding interrupt source (note that even in such a case, the corresponding bit of SRCPND register is set to 1). If the mask bit is 0, the interrupt request can be serviced.

Register	Address	R/W	Description	Reset Value
INTMSK	0X4A000008	R/W	Determine which interrupt source is masked. The masked interrupt source will not be serviced. 0 = Interrupt service is available. 1 = Interrupt service is masked.	0xFFFFFFFF

INTERRUPT MASK (INTMSK) REGISTER (Continued)

INTMSK	Bit	Description	Initial State
INT_ADC	[31]	0 = Service available, 1 = Masked	1
INT_RTC	[30]	0 = Service available, 1 = Masked	1
INT_SPI1	[29]	0 = Service available, 1 = Masked	1
INT_UART0	[28]	0 = Service available, 1 = Masked	1
INT_IIC	[27]	0 = Service available, 1 = Masked	1
INT_USBH	[26]	0 = Service available, 1 = Masked	1
INT_USBD	[25]	0 = Service available, 1 = Masked	1
INT_NFCON	[24]	0 = Service available, 1 = Masked	1
INT_UART1	[23]	0 = Service available, 1 = Masked	1
INT_SPI0	[22]	0 = Service available, 1 = Masked	1
INT_SDI	[21]	0 = Service available, 1 = Masked	1
INT_DMA3	[20]	0 = Service available, 1 = Masked	1
INT_DMA2	[19]	0 = Service available, 1 = Masked	1
INT_DMA1	[18]	0 = Service available, 1 = Masked	1
INT_DMA0	[17]	0 = Service available, 1 = Masked	1
INT_LCD	[16]	0 = Service available, 1 = Masked	1
INT_UART2	[15]	0 = Service available, 1 = Masked	1
INT_TIMER4	[14]	0 = Service available, 1 = Masked	1
INT_TIMER3	[13]	0 = Service available, 1 = Masked	1
INT_TIMER2	[12]	0 = Service available, 1 = Masked	1
INT_TIMER1	[11]	0 = Service available, 1 = Masked	1
INT_TIMER0	[10]	0 = Service available, 1 = Masked	1
INT_WDT_AC97	[9]	0 = Service available, 1 = Masked	1
INT_TICK	[8]	0 = Service available, 1 = Masked	1
nBATT_FLT	[7]	0 = Service available, 1 = Masked	1
INT_CAM	[6]	0 = Service available, 1 = Masked	1
EINT8_23	[5]	0 = Service available, 1 = Masked	1
EINT4_7	[4]	0 = Service available, 1 = Masked	1
EINT3	[3]	0 = Service available, 1 = Masked	1
EINT2	[2]	0 = Service available, 1 = Masked	1
EINT1	[1]	0 = Service available, 1 = Masked	1
EINT0	[0]	0 = Service available, 1 = Masked	1

PRIORITY REGISTER (PRIORITY)

Register	Address	R/W	Description	Reset Value
PRIORITY	0x4A00000C	R/W	IRQ priority control register	0x7F

PRIORITY	Bit	Description	Initial State
ARB_SEL6	[20:19]	Arbiter 6 group priority order set 00 = REQ 0-1-2-3-4-5 01 = REQ 0-2-3-4-1-5 10 = REQ 0-3-4-1-2-5 11 = REQ 0-4-1-2-3-5	00
ARB_SEL5	[18:17]	Arbiter 5 group priority order set 00 = REQ 1-2-3-4 01 = REQ 2-3-4-1 10 = REQ 3-4-1-2 11 = REQ 4-1-2-3	00
ARB_SEL4	[16:15]	Arbiter 4 group priority order set 00 = REQ 0-1-2-3-4-5 01 = REQ 0-2-3-4-1-5 10 = REQ 0-3-4-1-2-5 11 = REQ 0-4-1-2-3-5	00
ARB_SEL3	[14:13]	Arbiter 3 group priority order set 00 = REQ 0-1-2-3-4-5 01 = REQ 0-2-3-4-1-5 10 = REQ 0-3-4-1-2-5 11 = REQ 0-4-1-2-3-5	00
ARB_SEL2	[12:11]	Arbiter 2 group priority order set 00 = REQ 0-1-2-3-4-5 01 = REQ 0-2-3-4-1-5 10 = REQ 0-3-4-1-2-5 11 = REQ 0-4-1-2-3-5	00
ARB_SEL1	[10:9]	Arbiter 1 group priority order set 00 = REQ 0-1-2-3-4-5 01 = REQ 0-2-3-4-1-5 10 = REQ 0-3-4-1-2-5 11 = REQ 0-4-1-2-3-5	00
ARB_SEL0	[8:7]	Arbiter 0 group priority order set 00 = REQ 1-2-3-4 01 = REQ 2-3-4-1 10 = REQ 3-4-1-2 11 = REQ 4-1-2-3	00
ARB_MODE6	[6]	Arbiter 6 group priority rotate enable 0 = Priority does not rotate, 1 = Priority rotate enable	1
ARB_MODE5	[5]	Arbiter 5 group priority rotate enable 0 = Priority does not rotate, 1 = Priority rotate enable	1
ARB_MODE4	[4]	Arbiter 4 group priority rotate enable 0 = Priority does not rotate, 1 = Priority rotate enable	1
ARB_MODE3	[3]	Arbiter 3 group priority rotate enable 0 = Priority does not rotate, 1 = Priority rotate enable	1
ARB_MODE2	[2]	Arbiter 2 group priority rotate enable 0 = Priority does not rotate, 1 = Priority rotate enable	1
ARB_MODE1	[1]	Arbiter 1 group priority rotate enable 0 = Priority does not rotate, 1 = Priority rotate enable	1
ARB_MODE0	[0]	Arbiter 0 group priority rotate enable 0 = Priority does not rotate, 1 = Priority rotate enable	1

INTERRUPT PENDING (INTPND) REGISTER

Each of the 32 bits in the interrupt pending register shows whether the corresponding interrupt request, which is unmasked and waits for the interrupt to be serviced, has the highest priority. Since the INTPND register is located after the priority logic, only one bit can be set to 1, and that interrupt request generates IRQ to CPU. In interrupt service routine for IRQ, you can read this register to determine which interrupt source is serviced among the 32 sources.

Like the SRCPND register, this register has to be cleared in the interrupt service routine after clearing the SRCPND register. We can clear a specific bit of the INTPND register by writing a data to this register. It clears only the bit positions of the INTPND register corresponding to those set to one in the data. The bit positions corresponding to those that are set to 0 in the data remains as they are.

Register	Address	R/W	Description	Reset Value
INTPND	0X4A000010	R/W	Indicate the interrupt request status. 0 = The interrupt has not been requested. 1 = The interrupt source has asserted the interrupt request.	0x00000000

NOTE: If the FIQ mode interrupt occurs, the corresponding bit of INTPND will not be turned on as the INTPND register is available only for IRQ mode interrupt.

INTERRUPT PENDING (INTPND) REGISTER (Continued)

INTPND	Bit	Description	Initial State
INT_ADC	[31]	0 = Not requested, 1 = Requested	0
INT_RTC	[30]	0 = Not requested, 1 = Requested	0
INT_SPI1	[29]	0 = Not requested, 1 = Requested	0
INT_UART0	[28]	0 = Not requested, 1 = Requested	0
INT_IIC	[27]	0 = Not requested, 1 = Requested	0
INT_USBH	[26]	0 = Not requested, 1 = Requested	0
INT_USBD	[25]	0 = Not requested, 1 = Requested	0
INT_NFCON	[24]	0 = Not requested, 1 = Requested	0
INT_UART1	[23]	0 = Not requested, 1 = Requested	0
INT_SPI0	[22]	0 = Not requested, 1 = Requested	0
INT_SDI	[21]	0 = Not requested, 1 = Requested	0
INT_DMA3	[20]	0 = Not requested, 1 = Requested	0
INT_DMA2	[19]	0 = Not requested, 1 = Requested	0
INT_DMA1	[18]	0 = Not requested, 1 = Requested	0
INT_DMA0	[17]	0 = Not requested, 1 = Requested	0
INT_LCD	[16]	0 = Not requested, 1 = Requested	0
INT_UART2	[15]	0 = Not requested, 1 = Requested	0
INT_TIMER4	[14]	0 = Not requested, 1 = Requested	0
INT_TIMER3	[13]	0 = Not requested, 1 = Requested	0
INT_TIMER2	[12]	0 = Not requested, 1 = Requested	0
INT_TIMER1	[11]	0 = Not requested, 1 = Requested	0
INT_TIMER0	[10]	0 = Not requested, 1 = Requested	0
INT_WDT_AC97	[9]	0 = Not requested, 1 = Requested	0
INT_TICK	[8]	0 = Not requested, 1 = Requested	0
nBATT_FLT	[7]	0 = Not requested, 1 = Requested	0
INT_CAM	[6]	0 = Not requested, 1 = Requested	0
EINT8_23	[5]	0 = Not requested, 1 = Requested	0
EINT4_7	[4]	0 = Not requested, 1 = Requested	0
EINT3	[3]	0 = Not requested, 1 = Requested	0
EINT2	[2]	0 = Not requested, 1 = Requested	0
EINT1	[1]	0 = Not requested, 1 = Requested	0
EINT0	[0]	0 = Not requested, 1 = Requested	0

INTERRUPT OFFSET (INTOFFSET) REGISTER

The value in the interrupt offset register shows which interrupt request of IRQ mode is in the INTPND register. This bit can be cleared automatically by clearing SRCPND and INTPND.

Register	Address	R/W	Description	Reset Value
INTOFFSET	0x4A000014	R	Indicate the IRQ interrupt request source	0x00000000

INT Source	The OFFSET value	INT Source	The OFFSET value
INT_ADC	31	INT_UART2	15
INT_RTC	30	INT_TIMER4	14
INT_SPI1	29	INT_TIMER3	13
INT_UART0	28	INT_TIMER2	12
INT_IIC	27	INT_TIMER1	11
INT_USBH	26	INT_TIMER0	10
INT_USBD	25	INT_WDT_AC97	9
INT_NFCON	24	INT_TICK	8
INT_UART1	23	nBATT_FLT	7
INT_SPI0	22	INT_CAM	6
INT_SDI	21	EINT8_23	5
INT_DMA3	20	EINT4_7	4
INT_DMA2	19	EINT3	3
INT_DMA1	18	EINT2	2
INT_DMA0	17	EINT1	1
INT_LCD	16	EINT0	0

NOTE: FIQ mode interrupt does not affect the INTOFFSET register as the register is available only for IRQ mode interrupt.

SUB SOURCE PENDING (SUBSRCPND) REGISTER

You can clear a specific bit of the SUBSRCPND register by writing a data to this register. It clears only the bit positions of the SUBSRCPND register corresponding to those set to one in the data. The bit positions corresponding to those that are set to 0 in the data remains as they are.

Register	Address	R/W	Description	Reset Value
SUBSRCPND	0X4A000018	R/W	Indicate the interrupt request status. 0 = The interrupt has not been requested. 1 = The interrupt source has asserted the interrupt request.	0x00000000

SUBSRCPND	Bit	Description	Initial State
Reserved	[31:15]	Not used	0
INT_AC97	[14]	0 = Not requested, 1 = Requested	0
INT_WDT	[13]	0 = Not requested, 1 = Requested	0
INT_CAM_P	[12]	0 = Not requested, 1 = Requested	0
INT_CAM_C	[11]	0 = Not requested, 1 = Requested	0
INT_ADC_S	[10]	0 = Not requested, 1 = Requested	0
INT_TC	[9]	0 = Not requested, 1 = Requested	0
INT_ERR2	[8]	0 = Not requested, 1 = Requested	0
INT_TXD2	[7]	0 = Not requested, 1 = Requested	0
INT_RXD2	[6]	0 = Not requested, 1 = Requested	0
INT_ERR1	[5]	0 = Not requested, 1 = Requested	0
INT_TXD1	[4]	0 = Not requested, 1 = Requested	0
INT_RXD1	[3]	0 = Not requested, 1 = Requested	0
INT_ERR0	[2]	0 = Not requested, 1 = Requested	0
INT_TXD0	[1]	0 = Not requested, 1 = Requested	0
INT_RXD0	[0]	0 = Not requested, 1 = Requested	0

Map To SRCPND

SRCPND	SUBSRCPND	Remark
INT_UART0	INT_RXD0,INT_TXD0,INT_ERR0	
INT_UART1	INT_RXD1,INT_TXD1,INT_ERR1	
INT_UART2	INT_RXD2,INT_TXD2,INT_ERR2	
INT_ADC	INT_ADC_S, INT_TC	
INT_CAM	INT_CAM_C, INT_CAM_P	
INT_WDT_AC97	INT_WDT, INT_AC97	

INTERRUPT SUB MASK (INTSUBMSK) REGISTER

This register has 11 bits each of which is related to an interrupt source. If a specific bit is set to 1, the interrupt request from the corresponding interrupt source is not serviced by the CPU (note that even in such a case, the corresponding bit of the SUBSRCPND register is set to 1). If the mask bit is 0, the interrupt request can be serviced.

Register	Address	R/W	Description	Reset Value
INTSUBMSK	0X4A00001C	R/W	Determine which interrupt source is masked. The masked interrupt source will not be serviced. 0 = Interrupt service is available. 1 = Interrupt service is masked.	0xFFFF

INTSUBMSK	Bit	Description	Initial State
Reserved	[31:15]	Not used	0
INT_AC97	[14]	0 = Service available, 1 = Masked	1
INT_WDT	[13]	0 = Service available, 1 = Masked	1
INT_CAM_P	[12]	0 = Service available, 1 = Masked	1
INT_CAM_C	[11]	0 = Service available, 1 = Masked	1
INT_ADC_S	[10]	0 = Service available, 1 = Masked	1
INT_TC	[9]	0 = Service available, 1 = Masked	1
INT_ERR2	[8]	0 = Service available, 1 = Masked	1
INT_TXD2	[7]	0 = Service available, 1 = Masked	1
INT_RXD2	[6]	0 = Service available, 1 = Masked	1
INT_ERR1	[5]	0 = Service available, 1 = Masked	1
INT_TXD1	[4]	0 = Service available, 1 = Masked	1
INT_RXD1	[3]	0 = Service available, 1 = Masked	1
INT_ERR0	[2]	0 = Service available, 1 = Masked	1
INT_TXD0	[1]	0 = Service available, 1 = Masked	1
INT_RXD0	[0]	0 = Service available, 1 = Masked	1

15

LCD CONTROLLER

OVERVIEW

The LCD controller in the S3C2440A consists of the logic for transferring LCD image data from a video buffer located in system memory to an external LCD driver.

The LCD controller supports monochrome, 2-bit per pixel (4-level gray scale) or 4-bit per pixel (16-level gray scale) mode on a monochrome LCD, using a time-based dithering algorithm and Frame Rate Control (FRC) method and it can be interfaced with a color LCD panel at 8-bit per pixel (256-level color) and 12-bit per pixel (4096-level color) for interfacing with STN LCD.

It can support 1-bit per pixel, 2-bit per pixel, 4-bit per pixel, and 8-bit per pixel for interfacing with the palletized TFT color LCD panel, and 16-bit per pixel and 24-bit per pixel for non-palletized true-color display.

The LCD controller can be programmed to support different requirements on the screen related to the number of horizontal and vertical pixels, data line width for the data interface, interface timing, and refresh rate.

FEATURES

STN LCD Displays:

- Supports 3 types of LCD panels: 4-bit dual scan, 4-bit single scan, and 8-bit single scan display type
- Supports the monochrome, 4 gray levels, and 16 gray levels
- Supports 256 colors and 4096 colors for color STN LCD panel
- Supports multiple screen size
Typical actual screen size: 640 x 480, 320 x 240, 160 x 160, and others
Maximum virtual screen size is 4Mbytes.
Maximum virtual screen size in 256 color mode: 4096 x 1024, 2048 x 2048, 1024 x 4096, and others

TFT LCD Displays:

- Supports 1, 2, 4 or 8-bpp (bit per pixel) palletized color displays for TFT
- Supports 16, 24-bpp non-palletized true-color displays for color TFT
- Supports maximum 16M color TFT at 24bit per pixel mode
- Supports multiple screen size
Typical actual screen size: 640 x 480, 320 x 240, 160 x 160, and others
Maximum virtual screen size is 4Mbytes.
Maximum virtual screen size in 64K color mode: 2048 x 1024 and others

COMMON FEATURES

The LCD controller has a dedicated DMA that supports to fetch the image data from video buffer located in system memory. Its features also include:

- Dedicated interrupt functions (INT_FrSyn and INT_FiCnt)
- The system memory is used as the display memory.
- Supports Multiple Virtual Display Screen (Supports Hardware Horizontal/Vertical Scrolling)
- Programmable timing control for different display panels
- Supports little and big-endian byte ordering, as well as WinCE data formats
- Supports 2-type SEC TFT LCD panel

(SAMSUNG 3.5" Portrait / 256K Color /Reflective and Transflective a-Si TFT LCD)

LTS350Q1-PD1: TFT LCD panel with touch panel and front light unit (Reflective type)

LTS350Q1-PD2: TFT LCD panel only

LTS350Q1-PE1: TFT LCD panel with touch panel and front light unit (Transflective type)

LTS350Q1-PE2: TFT LCD panel only

NOTE

WinCE doesn't support the 12-bit packed data format.
Please check if WinCE can support the 12-bit color-mode.

EXTERNAL INTERFACE SIGNAL

STN	TFT	SEC TFT (LTS350Q1-PD1/2)	SEC TFT (LTS350Q1-PE1/2)
VFRAME (Frame sync. Signal)	VSYNC (Vertical sync. Signal)	STV	STV
VLINE (Line sync pulse signal)	HSYNC (Horizontal sync. Signal)	CPV	CPV
VCLK (Pixel clock signal)	VCLK (Pixel clock signal)	LCD_HCLK	LCD_HCLK
VD[23:0] (LCD pixel data output ports)	VD[23:0] (LCD pixel data output ports)	VD[23:0]	VD[23:0]
VM (AC bias signal for LCD driver)	VDEN (Data enable signal)	TP	TP
—	LEND (Line end signal)	STH	STH
LCD_PWREN	LCD_PWREN	LCD_PWREN	LCD_PWREN
—	—	LPC_OE	LCC_INV
—	—	LPC_REV	LCC_REV
—	—	LPC_REVB	LCC_REVB

BLOCK DIAGRAM

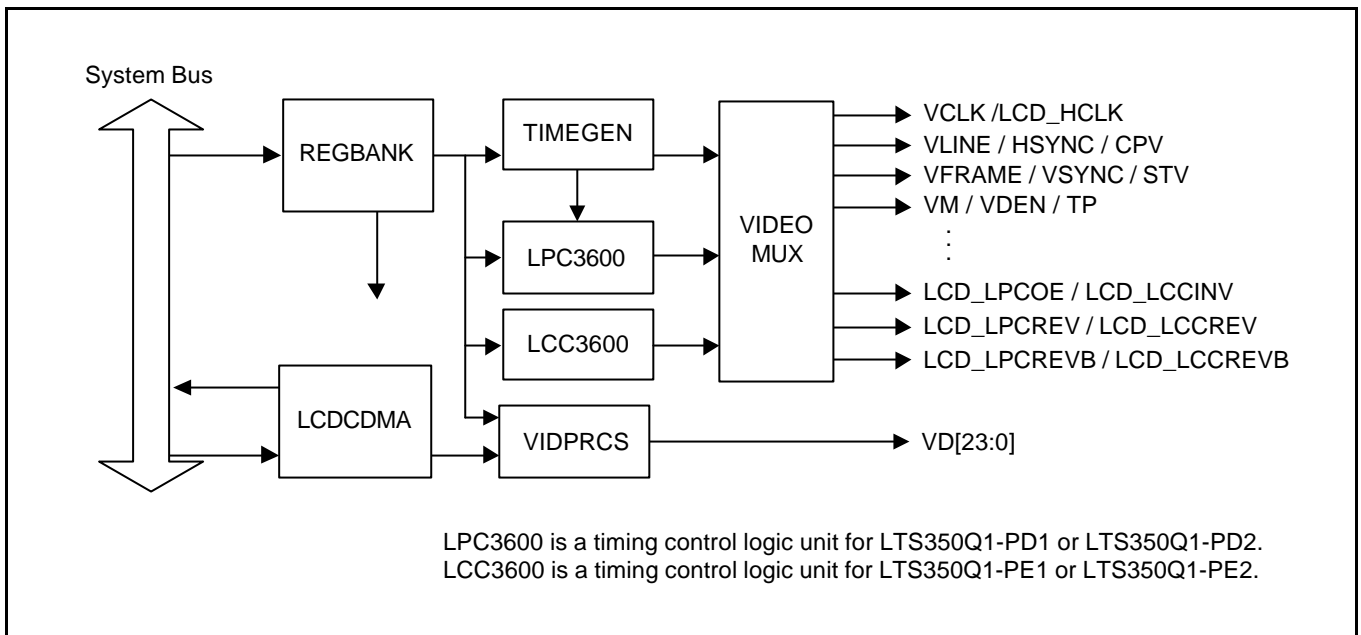

Figure 15-1. LCD Controller Block Diagram

The S3C2440A LCD controller is used to transfer the video data and to generate the necessary control signals, such as VFRAME, VLINE, VCLK, VM, and so on. In addition to the control signals, the S3C2440A has the data ports for video data, which are VD[23:0] as shown in Figure 15-1. The LCD controller consists of a REGBANK, LCDCDMA, VIDPRCS, TIMEGEN, and LPC3600 (See the Figure 15-1 LCD Controller Block Diagram). The REGBANK has 17 programmable register sets and 256x16 palette memory which are used to configure the LCD controller. The LCDCDMA is a dedicated DMA, which can transfer the video data in frame memory to LCD driver automatically. By using this special DMA, the video data can be displayed on the screen without CPU intervention. The VIDPRCS receives the video data from the LCDCDMA and sends the video data through the VD[23:0] data ports to the LCD driver after changing them into a suitable data format, for example 4/8-bit single scan or 4-bit dual scan display mode. The TIMEGEN consists of programmable logic to support the variable requirements of interface timing and rates commonly found in different LCD drivers. The TIMEGEN block generates VFRAME, VLINE, VCLK, VM, and so on.

The description of data flow is as follows:

FIFO memory is present in the LCDCDMA. When FIFO is empty or partially empty, the LCDCDMA requests data fetching from the frame memory based on the burst memory transfer mode (consecutive memory fetching of 4 words (16 bytes) per one burst request without allowing the bus mastership to another bus master during the bus transfer). When the transfer request is accepted by bus arbitrator in the memory controller, there will be four successive word data transfers from system memory to internal FIFO. The total size of FIFO is 28 words, which consists of 12 words FIFOL and 16 words FIFOH, respectively. The S3C2440A has two FIFOs to support the dual scan display mode. In case of single scan mode, one of the FIFOs (FIFOH) can only be used.

STN LCD CONTROLLER OPERATION

TIMING GENERATOR (TIMEGEN)

The TIMEGEN generates the control signals for the LCD driver, such as VFRAME, VLINE, VCLK, and VM. These control signals are closely related to the configuration on the LCDCON1/2/3/4/5 registers in the REG BANK. Based on these programmable configurations on the LCD control registers in the REG BANK, the TIMEGEN can generate the programmable control signals suitable to support many different types of LCD drivers.

The VFRAME pulse is asserted for the duration of the entire first line at a frequency of once per frame. The VFRAME signal is asserted to bring the LCD's line pointer to the top of the display to start over.

The VM signal helps the LCD driver alternate the polarity of the row and column voltages, which are used to turn the pixel on and off. The toggling rate of VM signals depends on the MMODE bit of the LCDCON1 register and MVAL field of the LCDCON4 register. If the MMODE bit is 0, the VM signal is configured to toggle on every frame. If the MMODE bit is 1, the VM signal is configured to toggle on the every event of the elapse of the specified number of VLINE by the MVAL[7:0] value. Figure 15-4 shows an example for MMODE=0 and for MMODE=1 with the value of MVAL[7:0]=0x2. When MMODE=1, the VM rate is related to MVAL[7:0], as shown below:

$$\text{VM Rate} = \text{VLINE Rate} / (2 \times \text{MVAL})$$

The VFRAME and VLINE pulse generation relies on the configurations of the HOZVAL field and the LINEVAL field in the LCDCON2/3 registers. Each field is related to the LCD size and display mode. In other words, the HOZVAL and LINEVAL can be determined by the size of the LCD panel and the display mode according to the following equation:

$$\text{HOZVAL} = (\text{Horizontal display size} / \text{Number of the valid VD data line}) - 1$$

$$\text{In color mode: Horizontal display size} = 3 \times \text{Number of Horizontal Pixel}$$

In the 4-bit single scan display mode, the Number of valid VD data line should be 4. In case of 4-bit dual scan display, the Number of valid VD data lines should also be 4 while in case of 8-bit single scan display mode, the Number of valid VD data line should be 8.

$$\text{LINEVAL} = (\text{Vertical display size}) - 1: \text{In case of single scan display type}$$

$$\text{LINEVAL} = (\text{Vertical display size} / 2) - 1: \text{In case of dual scan display type}$$

The rate of VCLK signal depends on the configuration of the CLKVAL field in the LCDCON1 register. Table 15-1 defines the relationship of VCLK and CLKVAL. The minimum value of CLKVAL is 2.

$$\text{VCLK(Hz)} = \text{HCLK} / (\text{CLKVAL} \times 2)$$

The frame rate is the VFRAME signal frequency. The frame rate is closely related to the field of WLH[1:0] (VLINE pulse width) WDLY[1:0] (the delay width of VCLK after VLINE pulse), HOZVAL, LINEBLANK, and LINEVAL in the LCDCON1/2/3/4 registers as well as VCLK and HCLK. Most LCD drivers need their own adequate frame rate. The frame rate is calculated as follows:

$$\text{frame_rate(Hz)} = 1 / [\{ (1/\text{VCLK}) \times (\text{HOZVAL} + 1) + (1/\text{HCLK}) \times (\mathbf{A} + \mathbf{B} + (\text{LINEBLANK} \times 8)) \} \times (\text{LINEVAL} + 1)]$$

$$\mathbf{A} = 2^{(4 + \text{WLH})}, \quad \mathbf{B} = 2^{(4 + \text{WDLY})}$$

Table 15-1. Relation Between VCLK and CLKVAL (STN, HCLK = 60MHz)

CLKVAL	60MHz/X	VCLK
2	60 MHz/4	15.0 MHz
3	60 MHz/6	10.0 MHz
:	:	:
1023	60 MHz/2046	29.3 kHz

VIDEO OPERATION

The S3C2440A LCD controller supports 8-bit color mode (256 color mode), 12-bit color mode (4096 color mode), 4 level gray scale mode, 16 level gray scale mode as well as the monochrome mode. For the gray or color mode, it is required to implement the shades of gray level or color according to time-based dithering algorithm and Frame Rate Control (FRC) method. The selection can be made following a programmable lockup table, which will be explained later. The monochrome mode bypasses these modules (FRC and lookup table) and basically serializes the data in FIFOH (and FIFOL if a dual scan display type is used) into 4-bit (or 8-bit if a 4-bit dual scan or 8-bit single scan display type is used) streams by shifting the video data to the LCD driver.

The following sections describe the operation on the gray and color mode in terms of the lookup table and FRC.

Lookup Table

The S3C2440A can support the lookup table for various selection of color or gray level mapping, ensuring flexible operation for users. The lookup table is the palette which allows the selection on the level of color or gray (Selection on 4-gray levels among 16 gray levels in case of 4 gray mode, selection on 8 red levels among 16 levels, 8 green levels among 16 levels and 4 blue levels among 16 levels in case of 256 color mode). In other words, users can select 4 gray levels among 16 gray levels by using the lookup table in the 4 gray level mode. The gray levels cannot be selected in the 16 gray level mode; all 16 gray levels must be chosen among the possible 16 gray levels. In case of 256 color mode, 3 bits are allocated for red, 3 bits for green and 2 bits for blue. The 256 colors mean that the colors are formed from the combination of 8 red, 8 green and 4 blue levels ($8 \times 8 \times 4 = 256$). In the color mode, the lookup table can be used for suitable selections. Eight red levels can be selected among 16 possible red levels, 8 green levels among 16 green levels, and 4 blue levels among 16 blue levels. In case of 4096 color mode, there is no selection as in the 256 color mode.

Gray Mode Operation

The S3C2440A LCD controller supports two gray modes: 2-bit per pixel gray (4 level gray scale) and 4-bit per pixel gray (16 level gray scale). The 2-bit per pixel gray mode uses a lookup table (BLUELUT), which allows selection on 4 gray levels among 16 possible gray levels. The 2-bit per pixel gray lookup table uses the BLUEVAL[15:0] in Blue Lookup Table (BLUELUT) register as same as blue lookup table in color mode. The gray level 0 will be denoted by BLUEVAL[3:0] value. If BLUEVAL[3:0] is 9, level 0 will be represented by gray level 9 among 16 gray levels. If BLUEVAL[3:0] is 15, level 0 will be represented by gray level 15 among 16 gray levels, and so on. Following the same method as above, level 1 will also be denoted by BLUEVAL[7:4], the level 2 by BLUEVAL[11:8], and the level 3 by BLUEVAL[15:12]. These four groups among BLUEVAL[15:0] will represent level 0, level 1, level 2, and level 3. In 16 gray levels, there is no selection as in the 16 gray levels.

256 Level Color Mode Operation

The S3C2440A LCD controller can support an 8-bit per pixel 256 color display mode. The color display mode can generate 256 levels of color using the dithering algorithm and FRC. The 8-bit per pixel are encoded into 3-bits for red, 3-bits for green, and 2-bits for blue. The color display mode uses separate lookup tables for red, green, and blue. Each lookup table uses the REDVAL[31:0] of REDLUT register, GREENVAL[31:0] of GREENLUT register, and BLUEVAL[15:0] of BLUELUT register as the programmable lookup table entries.

Similar to the gray level display, 8 group or field of 4 bits in the REDLUR register, i.e., REDVAL[31:28], REDLUT[27:24], REDLUT[23:20], REDLUT[19:16], REDLUT[15:12], REDLUT[11:8], REDLUT[7:4], and REDLUT[3:0], are assigned to each red level. The possible combination of 4 bits (each field) is 16, and each red level should be assigned to one level among possible 16 cases. In other words, the user can select the suitable red level by using this type of lookup table. For green color, the GREENVAL[31:0] of the GREENLUT register is assigned as the lookup table, as was done in the case of red color. Similarly, the BLUEVAL[15:0] of the BLUELUT register is also assigned as a lookup table. For blue color, 2 bits are allocated for 4 blue levels, different from the 8 red or green levels.

4096 Level Color Mode Operation

The S3C2440A LCD controller can support a 12-bit per pixel 4096 color display mode. The color display mode can generate 4096 levels of color using the dithering algorithm and FRC. The 12-bit per pixel are encoded into 4-bits for red, 4-bits for green, and 4-bits for blue. The 4096 color display mode does not use lookup tables.

DITHERING AND FRAME RATE CONTROL

In case of STN LCD display (except monochrome), video data must be processed by a dithering algorithm. The DITHFRC block has two functions, such as Time-based Dithering Algorithm for reducing flicker and Frame Rate Control (FRC) for displaying gray and color level on the STN panel. The main principle of gray and color level display on the STN panel based on FRC is described. For example, to display the third gray (3/16) level from a total of 16 levels, the 3 times pixel should be on and 13 times pixel off. In other words, 3 frames should be selected among the 16 frames, of which 3 frames should have a pixel-on on a specific pixel while the remaining 13 frames should have a pixel-off on a specific pixel. These 16 frames should be displayed periodically. This is basic principle on how to display the gray level on the screen, so-called gray level display by FRC. The actual example is shown in Table 15-2. To represent the 14th gray level in the table, we should have a 6/7 duty cycle, which mean that there are 6 times pixel-on and one time pixel-off. The other cases for all gray levels are also shown in Table 15-2.

In the STN LCD display, we should be reminded of one item, i.e., Flicker Noise due to the simultaneous pixel-on and -off on adjacent frames. For example, if all pixels on first frame are turned on and all pixels on next frame are turned off, the Flicker Noise will be maximized. To reduce the Flicker Noise on the screen, the average probability of pixel-on and -off between frames should be the same. In order to realize this, the Time-based Dithering Algorithm, which varies the pattern of adjacent pixels on every frame, should be used. This is explained in detail. For the 16 gray level, FRC should have the following relationship between gray level and FRC. The 15th gray level should always have pixel-on, and the 14th gray level should have 6 times pixel-on and one times pixel-off, and the 13th gray level should have 4 times pixel-on and one times pixel-off, ,, ,, ,, ,, ,, ,, ,, , and the 0th gray level should always have pixel-off as shown in Table 15-2.

Table 15-2. Dither Duty Cycle Examples

Pre-Dithered Data (gray level number)	Duty Cycle	Pre-Dithered Data (gray level number)	Duty Cycle
15	1	7	1/2
14	6/7	6	3/7
13	4/5	5	2/5
12	3/4	4	1/3
11	5/7	3	1/4
10	2/3	2	1/5
9	3/5	1	1/7
8	4/7	0	0

Display Types

The LCD controller supports 3 types of LCD drivers: 4-bit dual scan, 4-bit single scan, and 8-bit single scan display mode. Figure 15-2 shows these 3 different display types for monochrome displays, and Figure 15-3 show these 3 different display types for color displays.

4-bit Dual Scan Display Type

A 4-bit dual scan display uses 8 parallel data lines to shift data to both the upper and lower halves of the display at the same time. The 4 bits of data in the 8 parallel data lines are shifted to the upper half and 4 bits of data is shifted to the lower half, as shown in Figure 15-2. The end of frame is reached when each half of the display has been shifted and transferred. The 8 pins (VD[7:0]) for the LCD output from the LCD controller can be directly connected to the LCD driver.

4-bit Single Scan Display Type

A 4-bit single scan display uses 4 parallel data lines to shift data to successive single horizontal lines of the display at a time, until the entire frame has been shifted and transferred. The 4 pins (VD[3:0]) for the LCD output from the LCD controller can be directly connected to the LCD driver, and the 4 pins (VD[7:4]) for the LCD output are not used.

8-bit Single Scan Display Type

An 8-bit single scan display uses 8 parallel data lines to shift data to successive single horizontal lines of the display at a time, until the entire frame has been shifted and transferred. The 8 pins (VD[7:0]) for the LCD output from the LCD controller can be directly connected to the LCD driver.

256 Color Displays

Color displays require 3 bits (Red, Green, and Blue) of image data per pixel, so the number of horizontal shift registers for each horizontal line corresponds to three times the number of pixels of one horizontal line. These results in a horizontal shift register of length 3 times the number of pixels per horizontal line. This RGB is shifted to the LCD driver as consecutive bits via the parallel data lines. Figure 15-3 shows the RGB and order of the pixels in the parallel data lines for the 3 types of color displays.

4096 Color Displays

Color displays require 3 bits (Red, Green, and Blue) of image data per pixel, and so the number of horizontal shift registers for each horizontal line corresponds to three times the number of pixels of one horizontal line. This RGB is shifted to the LCD driver as consecutive bits via the parallel data lines. This RGB order is determined by the sequence of video data in video buffers.

MEMORY DATA FORMAT (STN, BSWP=0) (CONTINUED)

In **4-level gray mode**, 2 bits of video data correspond to 1 pixel.

In **16-level gray mode**, 4 bits of video data correspond to 1 pixel.

In **256 level color mode**, 8 bits (3 bits of red, 3 bits of green, and 2 bits of blue) of video data correspond to 1 pixel. The color data format in a byte is as follows:

Bit [7:5]	Bit [4:2]	Bit[1:0]
Red	Green	Blue

In **4096 level color mode** :

Packed 12 BPP color mode

12 bits (4 bits of red, 4 bits of green, 4 bits of blue) of video data correspond to 1 pixel. The following table shows color data format in words: (Video data must reside at 3 word boundaries (8 pixel), as follows)

RGB Order

DATA	[31:28]	[27:24]	[23:20]	[19:16]	[15:12]	[11:8]	[7:4]	[3:0]
Word #1	Red(1)	Green(1)	Blue(1)	Red(2)	Green(2)	Blue(2)	Red(3)	Green(3)
Word #2	Blue(3)	Red(4)	Green(4)	Blue(4)	Red(5)	Green(5)	Blue(5)	Red(6)
Word #3	Green(6)	Blue(6)	Red(7)	Green(7)	Blue(7)	Red(8)	Green(8)	Blue(8)

Unpacked 12 BPP color mode

12 bits (4 bits of red, 4 bits of green, 4 bits of blue) of video data correspond to 1 pixel. The following table shows color data format in words:

RGB Order

DATA	[31:28]	[27:24]	[23:20]	[19:16]	[15:12]	[11:8]	[7:4]	[3:0]
Word #1	–	Red(1)	Green(1)	Blue(1)	–	Red(2)	Green(2)	Blue(2)
Word #2	–	Red(3)	Green(3)	Blue(3)	–	Red(4)	Green(4)	Blue(4)
Word #3	–	Red(5)	Green(5)	Blue(5)	–	Red(6)	Green(6)	Blue(6)

16 BPP color mode

16 bits (5 bits of red, 6 bits of green, 5 bits of blue) of video data correspond to 1 pixel. But, stn controller will use only 12 bit color data. It means that only upper 4bit each color data will be used as pixel data (R[15:12], G[10:7], B[4:1]). The following table shows color data format in words:

RGB Order

DATA	[31:28]	[27:21]	[20:16]	[15:11]	[10:5]	[4:0]
Word #1	Red(1)	Green(1)	Blue(1)	Red(2)	Green(2)	Blue(2)
Word #2	Red(3)	Green(3)	Blue(3)	Red(4)	Green(4)	Blue(4)
Word #3	Red(5)	Green(5)	Blue(5)	Red(6)	Green(6)	Blue(6)

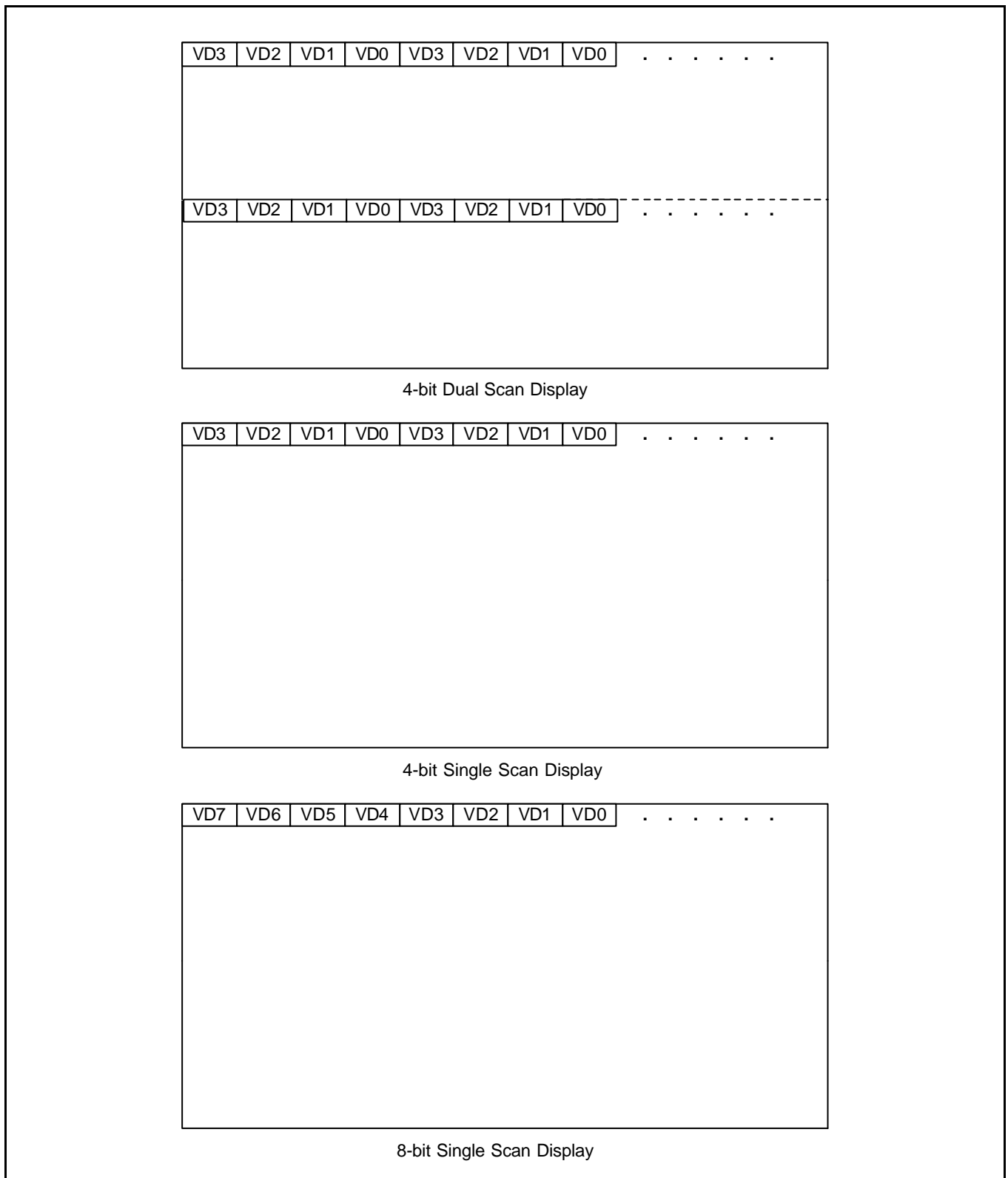

Figure 15-2. Monochrome Display Types (STN)

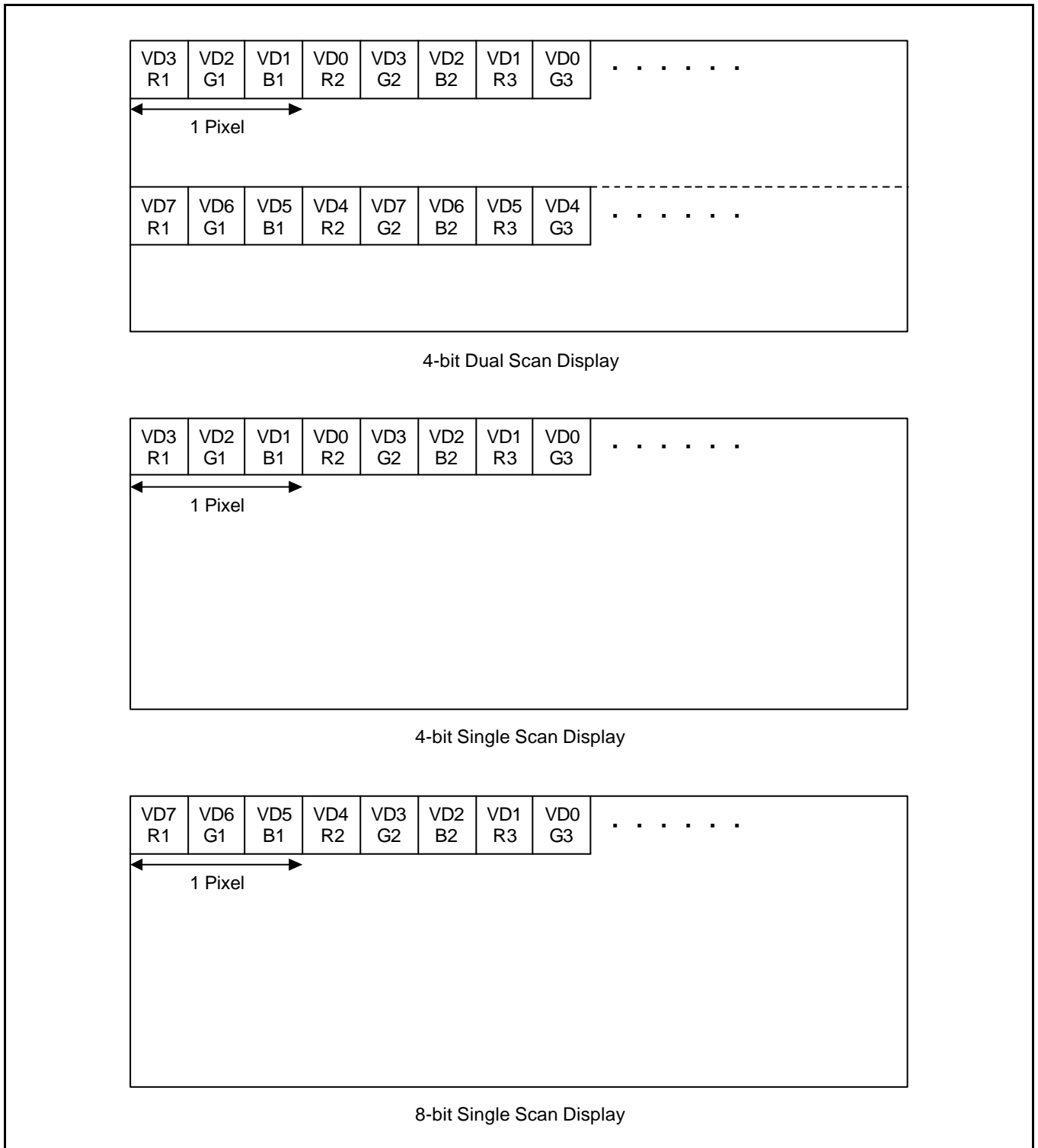

Figure 15-3. Color Display Types (STN)

Timing Requirements

Image data should be transferred from the memory to the LCD driver using the VD[7:0] signal. VCLK signal is used to clock the data into the LCD driver's shift register. After each horizontal line of data has been shifted into the LCD driver's shift register, the VLINE signal is asserted to display the line on the panel.

The VM signal provides an AC signal for the display. The LCD uses the signal to alternate the polarity of the row and column voltages, which are used to turn the pixels on and off, because the LCD plasma tends to deteriorate whenever subjected to a DC voltage. It can be configured to toggle on every frame or to toggle every programmable number of VLINE signals.

Figure 15-4 shows the timing requirements for the LCD driver interface.

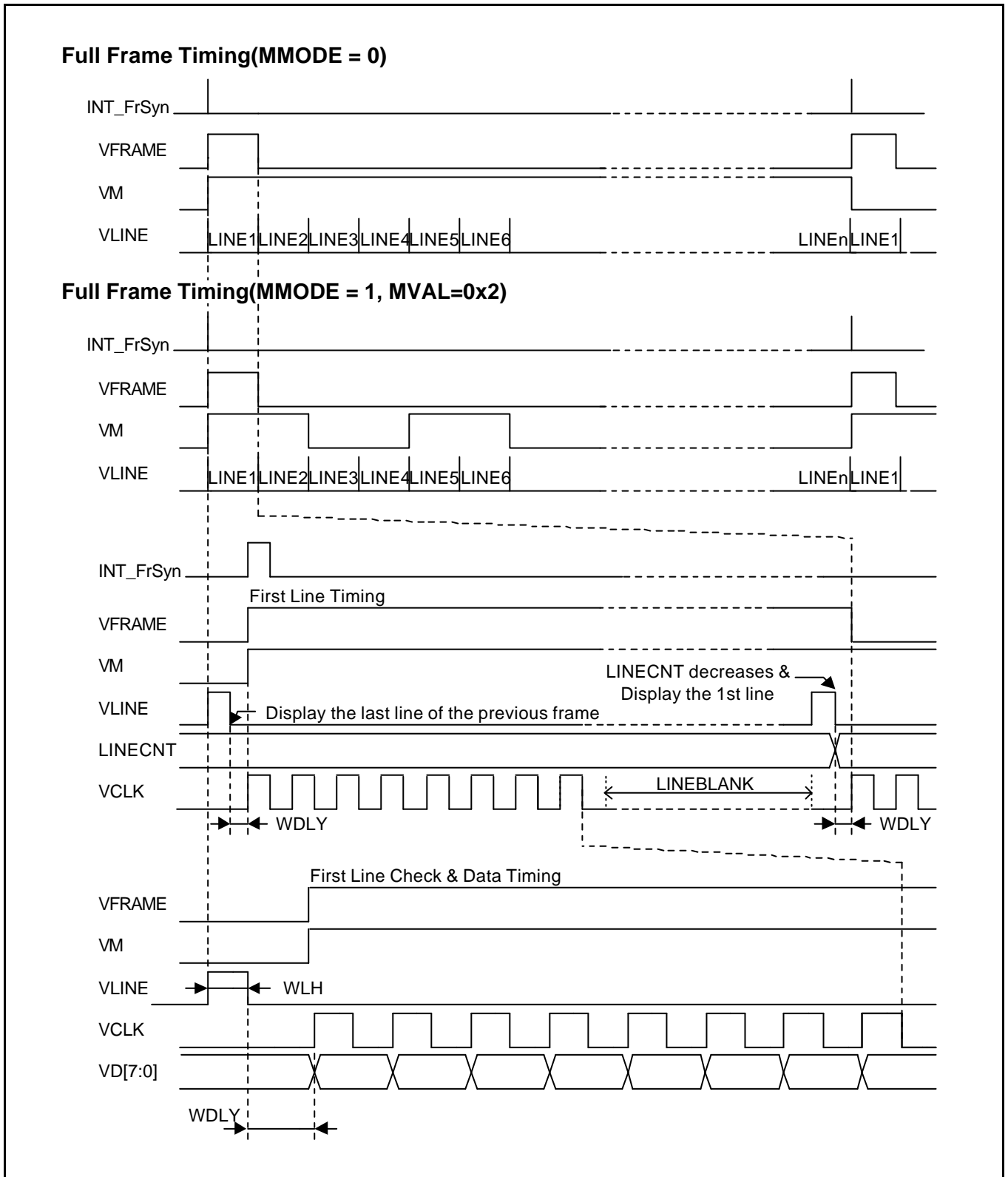

Figure 15-4. 8-bit Single Scan Display Type STN LCD Timing

TFT LCD CONTROLLER OPERATION

The TIMEGEN generates the control signals for LCD driver, such as VSYNC, HSYNC, VCLK, VDEN, and LEND signal. These control signals are highly related with the configurations on the LCDCON1/2/3/4/5 registers in the REGBANK. Base on these programmable configurations on the LCD control registers in the REGBANK, the TIMEGEN can generate the programmable control signals suitable for the support of many different types of LCD drivers.

The VSYNC signal is asserted to cause the LCD's line pointer to start over at the top of the display.

The VSYNC and HSYNC pulse generation depends on the configurations of both the HOZVAL field and the LINEVAL field in the LCDCON2/3 registers. The HOZVAL and LINEVAL can be determined by the size of the LCD panel according to the following equations:

- HOZVAL = (Horizontal display size) -1
- LINEVAL = (Vertical display size) -1

The rate of VCLK signal depends on the CLKVAL field in the LCDCON1 register. Table 15-3 defines the relationship of VCLK and CLKVAL. The minimum value of CLKVAL is 0.

$$VCLK(\text{Hz}) = HCLK / [(CLKVAL + 1) \times 2]$$

The frame rate is VSYNC signal frequency. The frame rate is related with the field of VSYNC, VBPD, VFPD, LINEVAL, HSYNC, HBPD, HFPD, HOZVAL, and CLKVAL in LCDCON1 and LCDCON2/3/4 registers. Most LCD drivers need their own adequate frame rate. The frame rate is calculated as follows:

$$\text{Frame Rate} = 1 / [\{ (VSPW + 1) + (VBPD + 1) + (LINEVAL + 1) + (VFPD + 1) \} \times \{ (HSPW + 1) + (HBPD + 1) + (HFPD + 1) + (HOZVAL + 1) \} \times \{ 2 \times (CLKVAL + 1) / (HCLK) \}]$$

Table 15-3. Relation between VCLK and CLKVAL (TFT, HCLK = 60MHz)

CLKVAL	60MHz/X	VCLK
1	60 MHz/4	15.0 MHz
2	60 MHz/6	10.0 MHz
:	:	:
1023	60 MHz/2048	30.0 kHz

VIDEO OPERATION

The TFT LCD controller within the S3C2440A supports 1, 2, 4 or 8 bpp (bit per pixel) palettized color displays and 16 or 24 bpp non-palettized true-color displays.

256 Color Palette

The S3C2440A can support the 256 color palette for various selection of color mapping, providing flexible operation for users.

MEMORY DATA FORMAT (TFT)

This section includes some examples of each display mode.

24BPP Display

(BSWP = 0, HWSWP = 0, BPP24BL = 0)

	D[31:24]	D[23:0]
000H	Dummy Bit	P1
004H	Dummy Bit	P2
008H	Dummy Bit	P3
...		

(BSWP = 0, HWSWP = 0, BPP24BL = 1)

	D[31:8]	D[7:0]
000H	P1	Dummy Bit
004H	P2	Dummy Bit
008H	P3	Dummy Bit
...		

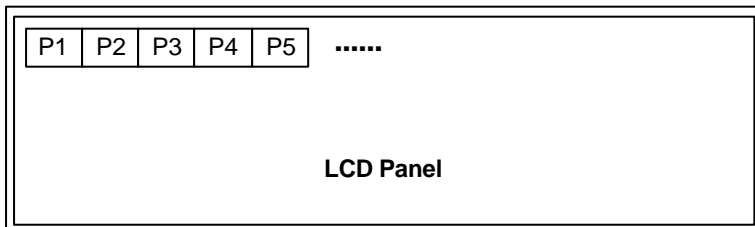

VD Pin Descriptions at 24BPP

VD	23	22	21	20	19	18	17	16	15	14	13	12	11	10	9	8	7	6	5	4	3	2	1	0
RED	7	6	5	4	3	2	1	0																
GREEN									7	6	5	4	3	2	1	0								
BLUE																	7	6	5	4	3	2	1	0

16BPP Display

(BSWP = 0, HWSWP = 0)

	D[31:16]	D[15:0]
000H	P1	P2
004H	P3	P4
008H	P5	P6
...		

(BSWP = 0, HWSWP = 1)

	D[31:16]	D[15:0]
000H	P2	P1
004H	P4	P3
008H	P6	P5
...		

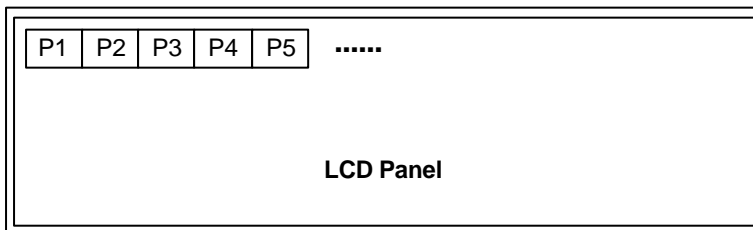

VD Pin Descriptions at 16BPP

(5:6:5)

VD	23	22	21	20	19	18	17	16	15	14	13	12	11	10	9	8	7	6	5	4	3	2	1	0	
RED	4	3	2	1	0	NC									NC								NC		
GREEN									5	4	3	2	1	0											
BLUE																	4	3	2	1	0				

(5:5:5:I)

VD	23	22	21	20	19	18	17	16	15	14	13	12	11	10	9	8	7	6	5	4	3	2	1	0	
RED	4	3	2	1	0	I	NC								NC									NC	
GREEN									4	3	2	1	0	I											
BLUE																	4	3	2	1	0	I			

NOTE: The unused VD pins can be used as GPIO

8BPP Display

(BSWP = 0, HWSWP = 0)

	D[31:24]	D[23:16]	D[15:8]	D[7:0]
000H	P1	P2	P3	P4
004H	P5	P6	P7	P8
008H	P9	P10	P11	P12
...				

(BSWP = 1, HWSWP = 0)

	D[31:24]	D[23:16]	D[15:8]	D[7:0]
000H	P4	P3	P2	P1
004H	P8	P7	P6	P5
008H	P12	P11	P10	P9
...				

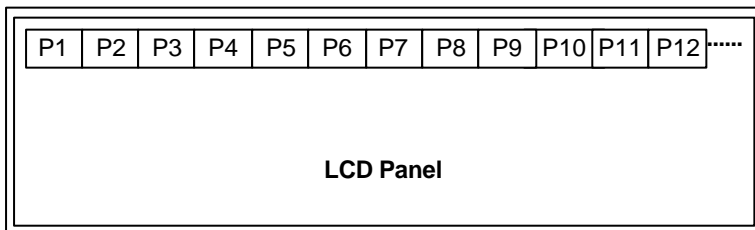

4BPP Display

(BSWP = 0, HWSWP = 0)

	D[31:28]	D[27:24]	D[23:20]	D[19:16]	D[15:12]	D[11:8]	D[7:4]	D[3:0]
000H	P1	P2	P3	P4	P5	P6	P7	P8
004H	P9	P10	P11	P12	P13	P14	P15	P16
008H	P17	P18	P19	P20	P21	P22	P23	P24
...								

(BSWP = 1, HWSWP = 0)

	D[31:28]	D[27:24]	D[23:20]	D[19:16]	D[15:12]	D[11:8]	D[7:4]	D[3:0]
000H	P7	P8	P5	P6	P3	P4	P1	P2
004H	P15	P16	P13	P14	P11	P12	P9	P10
008H	P23	P24	P21	P22	P19	P20	P17	P18
...								

2BPP Display

(BSWP = 0, HWSWP = 0)

D	[31:30]	[29:28]	[27:26]	[25:24]	[23:22]	[21:20]	[19:18]	[17:16]
000H	P1	P2	P3	P4	P5	P6	P7	P8
004H	P17	P18	P19	P20	P21	P22	P23	P24
008H	P33	P34	P35	P36	P37	P38	P39	P40
...								

D	[15:14]	[13:12]	[11:10]	[9:8]	[7:6]	[5:4]	[3:2]	[1:0]
000H	P9	P10	P11	P12	P13	P14	P15	P16
004H	P25	P26	P27	P28	P29	P30	P31	P32
008H	P41	P42	P43	P44	P45	P46	P47	P48
...								

256 PALETTE USAGE (TFT)

Palette Configuration and Format Control

The S3C2440A provides 256 color palette for TFT LCD Control.

The user can select 256 colors from the 64K colors in these two formats.

The 256 color palette consists of the 256 (depth) x 16-bit SPSRAM. The palette supports 5:6:5 (R:G:B) format and 5:5:5:1(R:G:B:I) format.

When the user uses 5:5:5:1 format, the intensity data(I) is used as a common LSB bit of each RGB data. So, 5:5:5:1 format is the same as R(5+I):G(5+I):B(5+I) format.

In 5:5:5:1 format, for example, the user can write the palette as in Table 15-5 and then connect VD pin to TFT LCD panel(R(5+I)=VD[23:19]+VD[18], VD[10] or VD[2], G(5+I)=VD[15:11]+ VD[18], VD[10] or VD[2], B(5+I)=VD[7:3]+ VD[18], VD[10] or VD[2].), and set FRM565 of LCDCON5 register to 0.

Table 15-4. 5:6:5 Format

INDEX\Bit Pos.	15	14	13	12	11	10	9	8	7	6	5	4	3	2	1	0	Address
00H	R4	R3	R2	R1	R0	G5	G4	G3	G2	G1	G0	B4	B3	B2	B1	B0	¹⁾ 0X4D000400
01H	R4	R3	R2	R1	R0	G5	G4	G3	G2	G1	G0	B4	B3	B2	B1	B0	0X4D000404
.....																
FFH	R4	R3	R2	R1	R0	G5	G4	G3	G2	G1	G0	B4	B3	B2	B1	B0	0X4D0007FC
Number of VD	23	22	21	20	19	15	14	13	12	11	10	7	6	5	4	3	

Table 15-5. 5:5:5:1 Format

INDEX\Bit Pos.	15	14	13	12	11	10	9	8	7	6	5	4	3	2	1	0	Address
00H	R4	R3	R2	R1	R0	G4	G3	G2	G1	G0	B4	B3	B2	B1	B0	I	0X4D000400
01H	R4	R3	R2	R1	R0	G4	G3	G2	G1	G0	B4	B3	B2	B1	B0	I	0X4D000404
.....																
FFH	R4	R3	R2	R1	R0	G4	G3	G2	G1	G0	B4	B3	B2	B1	B0	I	0X4D0007FC
Number of VD	23	22	21	20	19	15	14	13	12	11	7	6	5	4	3	²⁾	

NOTES:

- 0x4D000400 is Palette start address.
- VD18, VD10 and VD2 have the same output value, I.
- DATA[31:16] is invalid.

Palette Read/Write

When the user performs Read/Write operation on the palette, HSTATUS and VSTATUS of LCDCON5 register must be checked, for Read/Write operation is prohibited during the ACTIVE status of HSTATUS and VSTATUS.

Temporary Palette Configuration

The S3C2440A allows the user to fill a frame with one color without complex modification to fill the one color to the frame buffer or palette. The one colored frame can be displayed by the writing a value of the color which is displayed on LCD panel to TPALVAL of TPAL register and enable TPALEN.

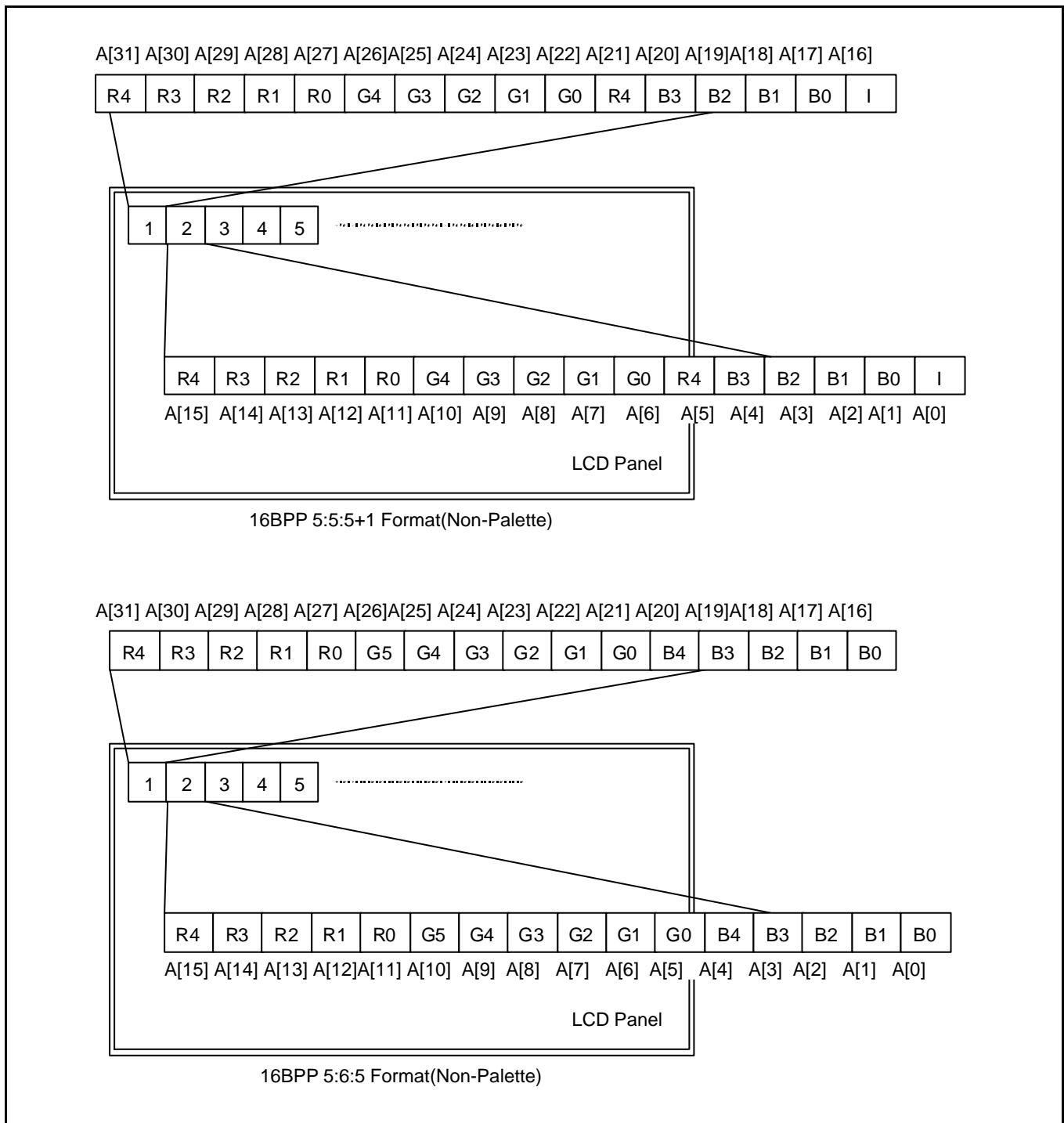

Figure 15-5. 16BPP Display Types (TFT)

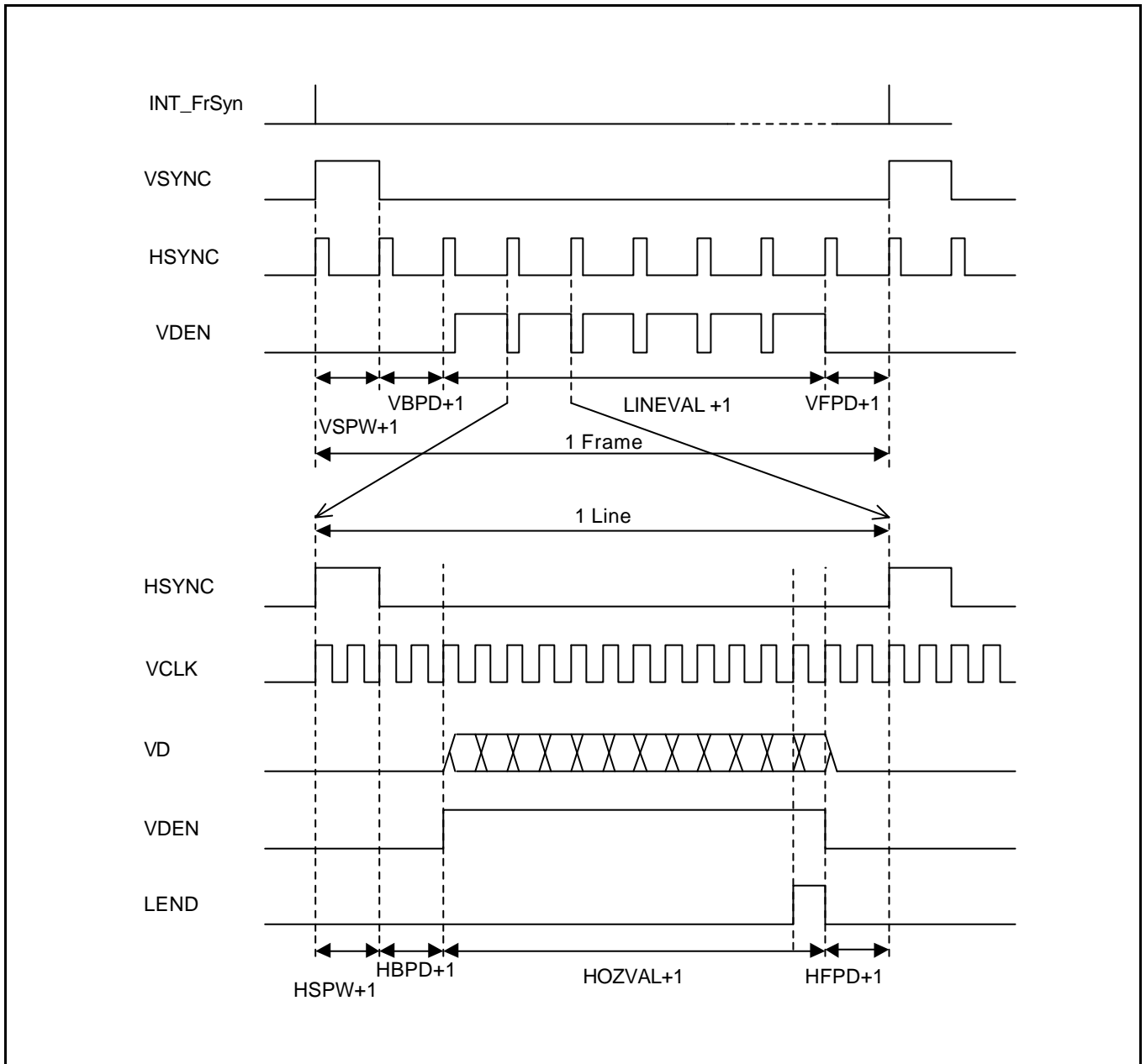

Figure 15-6. TFT LCD Timing Example

SAMSUNG TFT LCD PANEL (3.5" PORTRAIT / 256K COLOR / REFLECTIVE A-SI/TRANSFLECTIVE A-SI TFT LCD)

The S3C2440A supports following SEC TFT LCD panels.

1. SAMSUNG 3.5" Portrait / 256K Color /Reflective a-Si TFT LCD.
LTS350Q1-PD1: TFT LCD panel with touch panel and front light unit
LTS350Q1-PD2: TFT LCD panel only
2. SAMSUNG 3.5" Portrait / 256K Color /Transflective a-Si TFT LCD.
LTS350Q1-PE1: TFT LCD panel with touch panel and front light unit
LTS350Q1-PE2: TFT LCD panel only

The S3C2440A provides timing signals as follows to use LTS350Q1-PD1 / PD2 and LTS350Q1-PE1 / PE2

LTS350Q1-PD1 / PD2	LTS350Q1-PE1 / PE2
STH: Horizontal Start Pulse TP: Source Driver Data Load Pulse INV: Digital Data Inversion LCD_HCLK: Horizontal Sampling Clock CPV: Vertical Shift Clock STV: Vertical Start Pulse OE: Gate On Enable REV: Inversion Signal REVB: Inversion Signal	STH: Horizontal Start Pulse TP: Source Driver Data Load Pulse INV: Digital Data Inversion LCD_HCLK: Horizontal Sampling Clock CPV: Vertical Shift Clock STV: Vertical Start Pulse LCCINV: Source drive IC sampling inversion signal REV: VCOM modulation Signal REVB: Inversion Signal

So, LTS350Q1-PD1/2 and PE1/2 can be connected with the S3C2440A without using the additional timing control logic. But the user should additionally apply Vcom generator circuit, various voltages, INV signal and Gray scale voltage generator circuit, which is recommended by PRODUCT INFORMATION (SPEC) of LTS350Q1-PD1/2 and PE1/2. Detailed timing diagram is also described in PRODUCT INFORMATION (SPEC) of LTS350Q1-PD1/2 and PE1/2.

Refer to the documentation (PRODUCT INFORMATION of LTS350Q1-PD1/2 and PE1/2), which is prepared by AMLCD Technical Customer Center of Samsung Electronics Co., LTD.

Caution:

- The S3C2440A has HCLK, working as the clock of AHB bus.
- SEC TFT LCD panel (LTS350Q1-PD1/2 and PE1/2) has Horizontal Sampling Clock (HCLK).
- These two HCLKs may cause a confusion. So, note that HCLK of the S3C2440A is HCLK and other HCLK of the LTS350 is LCD_HCLK.

Check that the HCLK of SEC TFT LCD panel (LTS350Q1-PD1/2 and PE1/2) is changed to LCD_HCLK.

VIRTUAL DISPLAY (TFT/STN)

The S3C2440A supports hardware horizontal or vertical scrolling. If the screen is scrolled, the fields of LCDBASEU and LCDBASEL in LCDSADDR1/2 registers need to be changed (see Figure 15-8), except the values of PAGEWIDTH and OFFSIZE.

The video buffer in which the image is stored should be larger than the LCD panel screen in size.

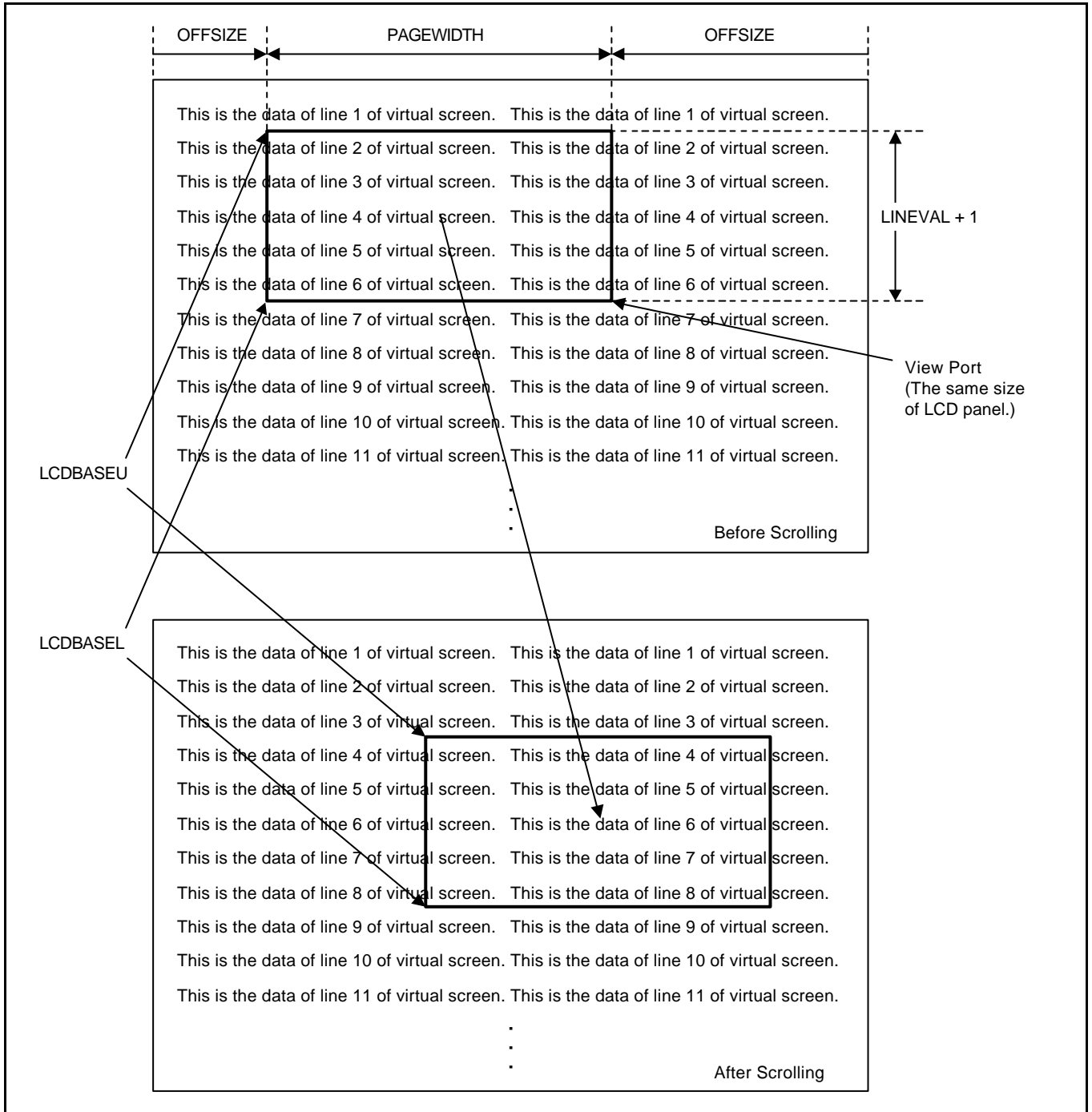

Figure 15-7. Example of Scrolling in Virtual Display (Single Scan)

LCD POWER ENABLE (STN/TFT)

The S3C2440A provides Power enable (PWREN) function. When PWREN is set to make PWREN signal enabled, the output value of LCD_PWREN pin is controlled by ENVID. In other words, If LCD_PWREN pin is connected to the power on/off control pin of the LCD panel, the power of LCD panel is controlled by the setting of ENVID automatically.

The S3C2440A also supports INVPWREN bit to invert polarity of the PWREN signal.

This function is available only when LCD panel has its own power on/off control port and when port is connected to LCD_PWREN pin.

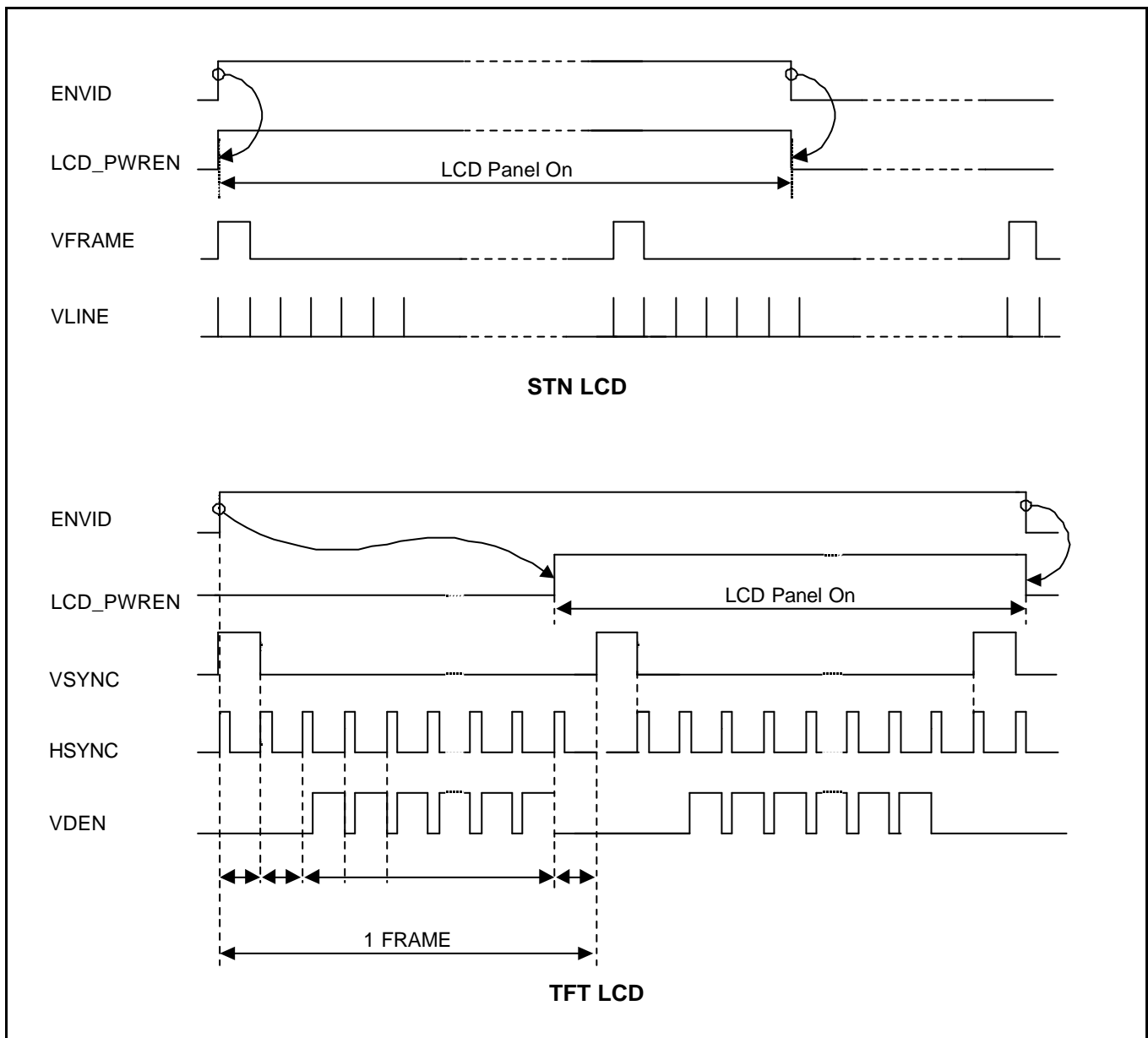

Figure 15-8. Example of PWREN Function (PWREN=1, INVPWREN=0)

LCD CONTROLLER SPECIAL REGISTERS

LCD Control 1 Register

Register	Address	R/W	Description	Reset Value
LCDCON1	0X4D000000	R/W	LCD control 1 register	0x00000000

LCDCON1	Bit	Description	Initial State
LINECNT (read only)	[27:18]	Provide the status of the line counter. Down count from LINEVAL to 0	0000000000
CLKVAL	[17:8]	Determine the rates of VCLK and CLKVAL[9:0]. STN: $VCLK = HCLK / (CLKVAL \times 2)$ ($CLKVAL \geq 2$) TFT: $VCLK = HCLK / [(CLKVAL+1) \times 2]$ ($CLKVAL \geq 0$)	0000000000
MMODE	[7]	Determine the toggle rate of the VM. 0 = Each Frame 1 = The rate defined by the MVAL	0
PNRMODE	[6:5]	Select the display mode. 00 = 4-bit dual scan display mode (STN) 01 = 4-bit single scan display mode (STN) 10 = 8-bit single scan display mode (STN) 11 = TFT LCD panel	00
BPPMODE	[4:1]	Select the BPP (Bits Per Pixel) mode. 0000 = 1 bpp for STN, Monochrome mode 0001 = 2 bpp for STN, 4-level gray mode 0010 = 4 bpp for STN, 16-level gray mode 0011 = 8 bpp for STN, color mode (256 color) 0100 = packed 12 bpp for STN, color mode (4096 color) 0101 = unpacked 12 bpp for STN, color mode (4096 color) 0110 = 16 bpp for STN, color mode (4096 color) 1000 = 1 bpp for TFT 1001 = 2 bpp for TFT 1010 = 4 bpp for TFT 1011 = 8 bpp for TFT 1100 = 16 bpp for TFT 1101 = 24 bpp for TFT	0000
ENVID	[0]	LCD video output and the logic enable/disable. 0 = Disable the video output and the LCD control signal. 1 = Enable the video output and the LCD control signal.	0

LCD Control 2 Register

Register	Address	R/W	Description	Reset Value
LCDCON2	0X4D000004	R/W	LCD control 2 register	0x00000000

LCDCON2	Bit	Description	Initial State
VBPD	[31:24]	TFT: Vertical back porch is the number of inactive lines at the start of a frame, after vertical synchronization period. STN: These bits should be set to zero on STN LCD.	0x00
LINEVAL	[23:14]	TFT/STN: These bits determine the vertical size of LCD panel.	0000000000
VFPD	[13:6]	TFT: Vertical front porch is the number of inactive lines at the end of a frame, before vertical synchronization period. STN: These bits should be set to zero on STN LCD.	00000000
VSPW	[5:0]	TFT: Vertical sync pulse width determines the VSYNC pulse's high level width by counting the number of inactive lines. STN: These bits should be set to zero on STN LCD.	000000

LCD Control 3 Register

Register	Address	R/W	Description	Reset Value
LCDCON3	0X4D000008	R/W	LCD control 3 register	0x00000000

LCDCON3	Bit	Description	Initial state
HBPD (TFT)	[25:19]	TFT: Horizontal back porch is the number of VCLK periods between the falling edge of HSYNC and the start of active data.	0000000
WDLY (STN)		STN: WDLY[1:0] bits determine the delay between VLINE and VCLK by counting the number of the HCLK. WDLY[7:2] are reserved. 00 = 16 HCLK, 01 = 32 HCLK, 10 = 48 HCLK, 11 = 64 HCLK	
HOZVAL	[18:8]	TFT/STN: These bits determine the horizontal size of LCD panel. HOZVAL has to be determined to meet the condition that total bytes of 1 line are 4n bytes. If the x size of LCD is 120 dot in mono mode, x=120 cannot be supported because 1 line consists of 15 bytes. Instead, x=128 in mono mode can be supported because 1 line is composed of 16 bytes (2n). LCD panel driver will discard the additional 8 dot.	00000000000
HFPD (TFT)	[7:0]	TFT: Horizontal front porch is the number of VCLK periods between the end of active data and the rising edge of HSYNC.	0X00
LINEBLANK (STN)		STN: These bits indicate the blank time in one horizontal line duration time. These bits adjust the rate of the VLINE finely. The unit of LINEBLANK is HCLK x 8. Ex) If the value of LINEBLANK is 10, the blank time is inserted to VCLK during 80 HCLK.	

Programming NOTE

: In case of STN LCD, (LINEBLANK + WLH + WDLY) value should be bigger than (14+12Tmax).

$$(\text{LINEBLANK} + \text{WLH} + \text{WDLY}) \geq (14 + 8xT_{\text{max}1} + 4xT_{\text{max}2} = 14 + 12T_{\text{max}})$$

LEGEND:

- (1) 14: SDRAM Auto refresh bus acquisition cycles
- (2) 8x Tmax1 : Cache fill cycle X the Slowest Memory access time(Ex, ROM)
- (3) 4x Tmax2 : 0xC~0xE address Frame memory Access time

LCD Control 4 Register

Register	Address	R/W	Description	Reset Value
LCDCON4	0X4D00000C	R/W	LCD control 4 register	0x00000000

LCDCON4	Bit	Description	Initial state
MVAL	[15:8]	STN: These bit define the rate at which the VM signal will toggle if the MMODE bit is set to logic '1'.	0X00
HSPW(TFT)	[7:0]	TFT: Horizontal sync pulse width determines the HSYNC pulse's high level width by counting the number of the VCLK.	0X00
WLH(STN)		STN: WLH[1:0] bits determine the VLINE pulse's high level width by counting the number of the HCLK. WLH[7:2] are reserved. 00 = 16 HCLK, 01 = 32 HCLK, 10 = 48 HCLK, 11 = 64 HCLK	

LCD Control 5 Register

Register	Address	R/W	Description	Reset Value
LCDCON5	0X4D000010	R/W	LCD control 5 register	0x00000000

LCDCON5	Bit	Description	Initial state
Reserved	[31:17]	This bit is reserved and the value should be '0'.	0
VSTATUS	[16:15]	TFT: Vertical Status (read only). 00 = VSYNC 01 = BACK Porch 10 = ACTIVE 11 = FRONT Porch	00
HSTATUS	[14:13]	TFT: Horizontal Status (read only). 00 = HSYNC 01 = BACK Porch 10 = ACTIVE 11 = FRONT Porch	00
BPP24BL	[12]	TFT: This bit determines the order of 24 bpp video memory. 0 = LSB valid 1 = MSB Valid	0
FRM565	[11]	TFT: This bit selects the format of 16 bpp output video data. 0 = 5:5:5:1 Format 1 = 5:6:5 Format	0
INVCLK	[10]	STN/TFT: This bit controls the polarity of the VCLK active edge. 0 = The video data is fetched at VCLK falling edge 1 = The video data is fetched at VCLK rising edge	0
INVLINE	[9]	STN/TFT: This bit indicates the VLINE/HSYNC pulse polarity. 0 = Normal 1 = Inverted	0
INVFRAME	[8]	STN/TFT: This bit indicates the VFRAME/VSYNC pulse polarity. 0 = Normal 1 = Inverted	0
INVVD	[7]	STN/TFT: This bit indicates the VD (video data) pulse polarity. 0 = Normal 1 = VD is inverted.	0

FRAME BUFFER START ADDRESS 1 REGISTER

Register	Address	R/W	Description	Reset Value
LCDSADDR1	0X4D000014	R/W	STN/TFT : Frame buffer start address 1 register	0x00000000

LCDSADDR1	Bit	Description	Initial State
LCDBANK	[29:21]	These bits indicate A[30:22] of the bank location for the video buffer in the system memory. LCDBANK value cannot be changed even when moving the view port. LCD frame buffer should be within aligned 4MB region, which ensures that LCDBANK value will not be changed when moving the view port. So, care should be taken to use the malloc() function.	0x00
LCDBASEU	[20:0]	For dual-scan LCD : These bits indicate A[21:1] of the start address of the upper address counter, which is for the upper frame memory of dual scan LCD or the frame memory of single scan LCD. For single-scan LCD : These bits indicate A[21:1] of the start address of the LCD frame buffer.	0x000000

FRAME Buffer Start Address 2 Register

Register	Address	R/W	Description	Reset Value
LCDSADDR2	0X4D000018	R/W	STN/TFT : Frame buffer start address 2 register	0x00000000

LCDSADDR2	Bit	Description	Initial State
LCDBASEL	[20:0]	For dual-scan LCD: These bits indicate A[21:1] of the start address of the lower address counter, which is used for the lower frame memory of dual scan LCD. For single scan LCD: These bits indicate A[21:1] of the end address of the LCD frame buffer. $\text{LCDBASEL} = ((\text{the frame end address}) \gg 1) + 1$ $= \text{LCDBASEU} + (\text{PAGEWIDTH} + \text{OFFSIZE}) \times (\text{LINEVAL} + 1)$	0x0000

NOTE: Users can change the LCDBASEU and LCDBASEL values for scrolling while the LCD controller is turned on. But, users must not change the value of the LCDBASEU and LCDBASEL registers at the end of FRAME by referring to the LINECNT field in LCDCON1 register, for the LCD FIFO fetches the next frame data prior to the change in the frame.

So, if you change the frame, the pre-fetched FIFO data will be obsolete and LCD controller will display an incorrect screen. To check the LINECNT, interrupts should be masked. If any interrupt is executed just after reading LINECNT, the read LINECNT value may be obsolete because of the execution time of Interrupt Service Routine (ISR).

FRAME Buffer Start Address 3 Register

Register	Address	R/W	Description	Reset Value
LCDSADDR3	0X4D00001C	R/W	STN/TFT : Virtual screen address set	0x00000000

LCDSADDR3	Bit	Description	Initial State
OFFSIZE	[21:11]	Virtual screen offset size (the number of half words). This value defines the difference between the address of the last half word displayed on the previous LCD line and the address of the first half word to be displayed in the new LCD line.	0000000000
PAGEWIDTH	[10:0]	Virtual screen page width (the number of half words). This value defines the width of the view port in the frame.	00000000

NOTE: The values of PAGEWIDTH and OFFSIZE must be changed when ENVID bit is 0.

Example 1. LCD panel = 320 x 240, 16gray, single scan

Frame start address = 0x0c500000

Offset dot number = 2048 dots (512 half words)

LINEVAL = 240-1 = 0xef

PAGEWIDTH = 320 x 4 / 16 = 0x50

OFFSIZE = 512 = 0x200

LCDBANK = 0x0c500000 >> 22 = 0x31

LCDBASEU = 0x100000 >> 1 = 0x80000

LCDBASEL = 0x80000 + (0x50 + 0x200) x (0xef + 1) = 0xa2b00

Example 2. LCD panel = 320 x 240, 16gray, dual scan

Frame start address = 0x0c500000

Offset dot number = 2048 dots (512 half words)

LINEVAL = 120-1 = 0x77

PAGEWIDTH = 320 x 4 / 16 = 0x50

OFFSIZE = 512 = 0x200

LCDBANK = 0x0c500000 >> 22 = 0x31

LCDBASEU = 0x100000 >> 1 = 0x80000

LCDBASEL = 0x80000 + (0x50 + 0x200) x (0x77 + 1) = 0x91580

Example 3. LCD panel = 320*240, color, single scan

Frame start address = 0x0c500000

Offset dot number = 1024 dots (512 half words)

LINEVAL = 240-1 = 0xef

PAGEWIDTH = 320 x 8 / 16 = 0xa0

OFFSIZE = 512 = 0x200

LCDBANK = 0x0c500000 >> 22 = 0x31

LCDBASEU = 0x100000 >> 1 = 0x80000

LCDBASEL = 0x80000 + (0xa0 + 0x200) x (0xef + 1) = 0xa7600

RED Lookup Table Register

Register	Address	R/W	Description	Reset Value
REDLUT	0X4D000020	R/W	STN: Red lookup table register	0x00000000

REDLUT	Bit	Description	Initial State
REDVAL	[31:0]	These bits define which of the 16 shades will be chosen by each of the 8 possible red combinations. 000 = REDVAL[3:0], 001 = REDVAL[7:4] 010 = REDVAL[11:8], 011 = REDVAL[15:12] 100 = REDVAL[19:16], 101 = REDVAL[23:20] 110 = REDVAL[27:24], 111 = REDVAL[31:28]	0x00000000

GREEN Lookup Table Register

Register	Address	R/W	Description	Reset Value
GREENLUT	0X4D000024	R/W	STN: Green lookup table register	0x00000000

GREENLUT	Bit	Description	Initial State
GREENVAL	[31:0]	These bits define which of the 16 shades will be chosen by each of the 8 possible green combinations. 000 = GREENVAL[3:0], 001 = GREENVAL[7:4] 010 = GREENVAL[11:8], 011 = GREENVAL[15:12] 100 = GREENVAL[19:16], 101 = GREENVAL[23:20] 110 = GREENVAL[27:24], 111 = GREENVAL[31:28]	0x00000000

BLUE Lookup Table Register

Register	Address	R/W	Description	Reset Value
BLUELUT	0X4D000028	R/W	STN: Blue lookup table register	0x0000

BULELUT	Bit	Description	Initial State
BLUEVAL	[15:0]	These bits define which of the 16 shades will be chosen by each of the 4 possible blue combinations. 00 = BLUEVAL[3:0], 01 = BLUEVAL[7:4] 10 = BLUEVAL[11:8], 11 = BLUEVAL[15:12]	0x0000

NOTE: Address from **0x14A0002C** to **0x14A00048** should not be used. This area is reserved for Test mode.

Dithering Mode Register

Register	Address	R/W	Description	Reset Value
DITHMODE	0X4D00004C	R/W	STN: Dithering mode register. This register reset value is 0x00000 But, user can change this value to 0x12210. (Refer to a sample program source for the latest value of this register.)	0x00000

DITHMODE	Bit	Description	Initial state
DITHMODE	[18:0]	Use one of following value for your LCD: 0x00000 or 0x12210	0x00000

LCD Interrupt Pending Register

Register	Address	R/W	Description	Reset Value
LCDINTPND	0X4D000054	R/W	Indicate the LCD interrupt pending register	0x0

LCDINTPND	Bit	Description	Initial state
INT_FrSyn	[1]	LCD frame synchronized interrupt pending bit. 0 = The interrupt has not been requested. 1 = The frame has asserted the interrupt request.	0
INT_FiCnt	[0]	LCD FIFO interrupt pending bit. 0 = The interrupt has not been requested. 1 = LCD FIFO interrupt is requested when LCD FIFO reaches trigger level.	0

LCD Source Pending Register

Register	Address	R/W	Description	Reset Value
LCDSRCPND	0X4D000058	R/W	Indicate the LCD interrupt source pending register	0x0

LCDSRCPND	Bit	Description	Initial state
INT_FrSyn	[1]	LCD frame synchronized interrupt source pending bit. 0 = The interrupt has not been requested. 1 = The frame has asserted the interrupt request.	0
INT_FiCnt	[0]	LCD FIFO interrupt source pending bit. 0 = The interrupt has not been requested. 1 = LCD FIFO interrupt is requested when LCD FIFO reaches trigger level.	0

TCON Control Register

Register	Address	R/W	Description	Reset Value
TCONSEL	0X4D000060	R/W	This register controls the LPC3600/LCC3600 modes.	0xF84

TCONSEL	Bit	Description	Initial state
LCC_TEST2	[11]	LCC3600 Test Mode 2 (Read Only)	1
LCC_TEST1	[10]	LCC3600 Test Mode 1 (Read Only)	1
LCC_SEL5	[9]	Select STV polarity	1
LCC_SEL4	[8]	Select CPV signal pin 0	1
LCC_SEL3	[7]	Select CPV signal pin 1	1
LCC_SEL2	[6]	Select Line/Dot inversion	0
LCC_SEL1	[5]	Select DG/Normal mode	0
LCC_EN	[4]	Determine LCC3600 Enable/Disable 0 = LCC3600 Disable 1 = LCC3600 Enable	0
CPV_SEL	[3]	Select CPV Pulse low width	0
MODE_SEL	[2]	Select DE/Sync mode 0 = Sync mode 1 = DE mode	1
RES_SEL	[1]	Select output resolution type 0 = 320 x 240 1 = 240 x 320	0
LPC_EN	[0]	Determine LPC3600 Enable/Disable 0 = LPC3600 Disable 1 = LPC3600 Enable	0

NOTE: Both LPC_EN and LCC_EN enable is not permitted. Only one TCON can be enabled at the same time.

Register Setting Guide (STN)

The LCD controller supports multiple screen sizes by special register setting.

The CLKVAL value determines the frequency of VCLK. This value has to be determined such that the VCLK value is greater than data transmission rate. The data transmission rate for the VD port of the LCD controller is used to determine the value of CLKVAL register.

The data transmission rate is given by the following equation:

$$\text{Data transmission rate} = \text{HS} \times \text{VS} \times \text{FR} \times \text{MV}$$

- HS: Horizontal LCD size
- VS: Vertical LCD size
- FR: Frame rate
- MV: Mode dependent value

Table 15-6. MV Value for Each Display Mode

Mode	MV Value
Mono, 4-bit single scan display	1/4
Mono, 8-bit single scan display or 4-bit dual scan display	1/8
4 level gray, 4-bit single scan display	1/4
4 level gray, 8-bit single scan display or 4-bit dual scan display	1/8
16 level gray, 4-bit single scan display	1/4
16 level gray, 8-bit single scan display or 4-bit dual scan display	1/8
Color, 4-bit single scan display	3/4
Color, 8-bit single scan display or 4-bit dual scan display	3/8

The LCDBASEU register value is the first address value of the frame buffer. The lowest 4 bits must be eliminated for burst 4 word access. The LCDBASEL register value depends on LCD size and LCDBASEU. The LCDBASEL value is given by the following equation:

- $\text{LCDBASEL} = \text{LCDBASEU} + \text{LCDBASEL offset}$

Example 1:

160 x 160, 4-level gray, 80 frame/sec, 4-bit single scan display, HCLK frequency is 60 MHz WLH = 1, WDLY = 1.

Data transmission rate = $160 \times 160 \times 80 \times 1/4 = 512$ kHz

CLKVAL = 58, VCLK = 517KHz

HOZVAL = 39, LINEVAL = 159

LINEBLANK = 10

LCDBASEL = LCDBASEU + 3200

NOTE

The higher the system load is, the lower the CPU performance.

Example 2 (Virtual screen register):

4-level gray, Virtual screen size = 1024 x 1024, LCD size = 320 x 240, LCDBASEU = 0x64, 4-bit dual scan.

1 halfword = 8 pixels (4-level gray),

Virtual screen 1 line = 128 halfword = 1024 pixels,

LCD 1 line = 320 pixels = 40 halfword,

OFFSIZE = $128 - 40 = 88 = 0x58$,

PAGEWIDTH = 40 = 0x28

LCDBASEL = LCDBASEU + (PAGEWIDTH + OFFSIZE) x (LINEVAL + 1) = $100 + (40 + 88) \times 120 = 0x3C64$

Gray Level Selection Guide

The S3C2440A LCD controller can generate 16 gray level using Frame Rate Control (FRC). The FRC characteristics may cause unexpected patterns in gray level. These unwanted erroneous patterns may be shown in fast response LCD or at lower frame rates.

Because the quality of LCD gray levels depends on LCD's own characteristics, the user has to select an appropriate gray level after viewing all gray levels on user's own LCD.

Select the gray level quality through the following procedures:

1. Get the latest dithering pattern register value from SAMSUNG.
2. Display 16 gray bar in LCD.
3. Change the frame rate into an optimal value.
4. Change the VM alternating period to get the best quality.
5. As viewing 16 gray bars, select a good gray level, which is displayed well on your LCD.
6. Use only the good gray levels for quality.

LCD Refresh Bus Bandwidth Calculation Guide

The S3C2440A LCD controller can support various LCD display sizes. To select a suitable size (for the flicker free LCD system application), the user have to consider the LCD refresh bus bandwidth determined by the LCD display size, bit per pixel (bpp), frame rate, memory bus width, memory type, and so on.

$$\text{LCD Data Rate (Byte/s)} = \text{bpp} \times (\text{Horizontal display size}) \times (\text{Vertical display size}) \times (\text{Frame rate}) / 8$$

$$\text{LCD DMA Burst Count (Times/s)} = \text{LCD Data Rate(Byte/s)} / 16(\text{Byte}) ; \text{LCD DMA using 4words(16Byte) burst}$$

Pdma means LCD DMA access period. In other words, the value of Pdma indicates the period of four-beat burst (4-words burst) for video data fetch. So, Pdma depends on memory type and memory setting.

Eventually, LCD System Load is determined by LCD DMA Burst Count and Pdma.

$$\text{— LCD System Load} = \text{LCD DMA Burst Count} \times \text{Pdma}$$

Example 3:

640 x 480, 8bpp, 60 frame/sec, 16-bit data bus width, SDRAM (Trp=2HCLK / Trcd=2HCLK / CL=2HCLK) and HCLK frequency is 60 MHz

$$\text{LCD Data Rate} = 8 \times 640 \times 480 \times 60 / 8 = 18.432\text{Mbyte/s}$$

$$\text{LCD DMA Burst Count} = 18.432 / 16 = 1.152\text{M/s}$$

$$\text{Pdma} = (\text{Trp} + \text{Trcd} + \text{CL} + (2 \times 4) + 1) \times (1/60\text{MHz}) = 0.250\text{ms}$$

$$\text{LCD System Load} = 1.152 \times 250 = 0.288$$

$$\text{System Bus Occupation Rate} = (0.288/1) \times 100 = 28.8\%$$

Register Setting Guide (TFT LCD)

The CLKVAL register value determines the frequency of VCLK and frame rate.

$$\text{Frame Rate} = 1 / [\{ (VSPW+1) + (VBPD+1) + (LINEVAL + 1) + (VFPD+1) \} \times \{ (HSPW+1) + (HBPD +1) + (HFPD+1) + (HOZVAL + 1) \} \times \{ 2 \times (CLKVAL+1) / (HCLK) \}]$$

For applications, the system timing must be considered to avoid under-run condition of the fifo of the lcd controller caused by memory bandwidth contention.

Example 4:

TFT Resolution: 240 x 240,

VSPW =2, VBPD =14, LINEVAL = 239, VFPD =4

HSPW =25, HBPD =15, HOZVAL = 239, HFPD =1

CLKVAL = 5

HCLK = 60 M (hz)

The parameters below must be referenced by LCD size and driver specifications:

VSPW, VBPD, LINEVAL, VFPD, HSPW, HBPD, HOZVAL, and HFPD

If target frame rate is 60–70Hz, then CLKVAL should be 5.

So, Frame Rate = 67Hz

16

ADC & TOUCH SCREEN INTERFACE

OVERVIEW

The 10-bit CMOS ADC (Analog to Digital Converter) is a recycling type device with 8-channel analog inputs. It converts the analog input signal into 10-bit binary digital codes at a maximum conversion rate of 500KSPS with 2.5MHz A/D converter clock. A/D converter operates with on-chip sample-and-hold function and power down mode is supported.

Touch Screen Interface can control/select pads (XP, XM, YP, YM) of the Touch Screen for X, Y position conversion. Touch Screen Interface contains Touch Screen Pads control logic and ADC interface logic with an interrupt generation logic.

FEATURES

- Resolution: 10-bit
- Differential Linearity Error: ± 1.0 LSB
- Integral Linearity Error: ± 2.0 LSB
- Maximum Conversion Rate: 500 KSPS
- Low Power Consumption
- Power Supply Voltage: 3.3V
- Analog Input Range: 0 ~ 3.3V
- On-chip sample-and-hold function
- Normal Conversion Mode
- Separate X/Y position conversion Mode
- Auto(Sequential) X/Y Position Conversion Mode
- Waiting for Interrupt Mode

ADC & TOUCH SCREEN INTERFACE OPERATION

BLOCK DIAGRAM

Figure 16-1 shows the functional block diagram of A/D converter and Touch Screen Interface. Note that the A/D converter device is a recycling type.

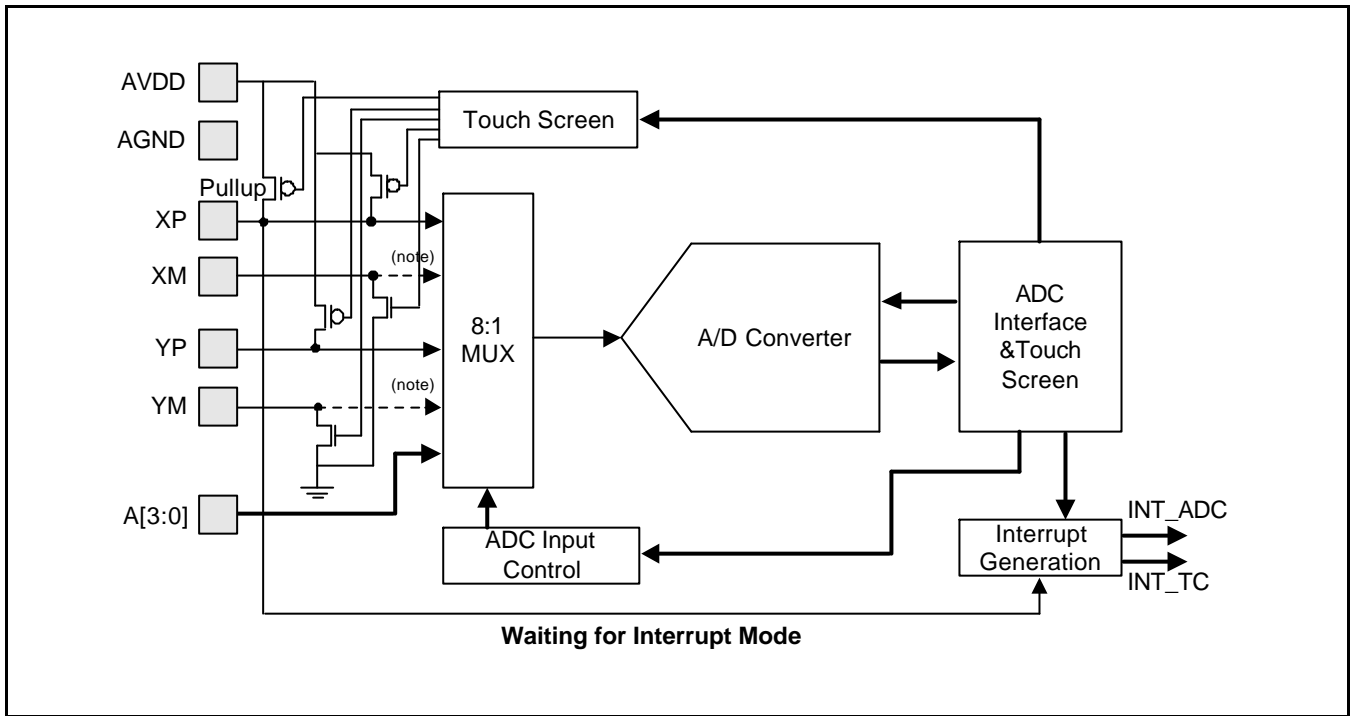

Figure 16-1. ADC and Touch Screen Interface Functional Block Diagram

NOTE: (symbol)

When Touch Screen device is used; XM or PM is only connected ground for Touch Screen I/F.

When Touch Screen device is not used, XM or PM is connecting Analog Input Signal for Normal ADC conversion.

FUNCTION DESCRIPTIONS

A/D Conversion Time

When the GCLK frequency is 50MHz and the prescaler value is 49, total 10-bit conversion time is as follows.

$$A/D \text{ converter freq.} = 50\text{MHz}/(49+1) = 1\text{MHz}$$

$$\text{Conversion time} = 1/(1\text{MHz} / 5\text{cycles}) = 1/200\text{KHz} = 5 \text{ us}$$

NOTE

This A/D converter was designed to operate at maximum 2.5MHz clock, so the conversion rate can go up to 500 KSPS.

Touch Screen Interface Mode

1. Normal Conversion Mode

Single Conversion Mode is the most likely used for General Purpose ADC Conversion. This mode can be initialized by setting the ADCCON (ADC Control Register) and completed with a read and a write to the ADCDAT0 (ADC Data Register 0).

2. Separate X/Y position conversion Mode

Touch Screen Controller can be operated by one of two Conversion Modes. Separate X/Y Position Conversion Mode is operated as the following way. X-Position Mode writes X-Position Conversion Data to ADCDAT0, so Touch Screen Interface generates the Interrupt source to Interrupt Controller. Y-Position Mode writes Y-Position Conversion Data to ADCDAT1, so Touch Screen Interface generates the Interrupt source to Interrupt Controller.

3. Auto(Sequential) X/Y Position Conversion Mode

Auto (Sequential) X/Y Position Conversion Mode is operated as the following. Touch Screen Controller sequentially converts X-Position and Y-Position that is touched. After Touch controller writes X-measurement data to ADCDAT0 and writes Y-measurement data to ADCDAT1, Touch Screen Interface is generating Interrupt source to Interrupt Controller in Auto Position Conversion Mode.

4. Waiting for Interrupt Mode

Touch Screen Controller generates interrupt (INT_TC) signal when the Stylus is down. Waiting for Interrupt Mode setting value is rADCTSC=0xd3; // XP_PU, XP_Dis, XM_Dis, YP_Dis, YM_En.

After Touch Screen Controller generates interrupt signal (INT_TC), Waiting for interrupt Mode must be cleared. (XY_PST sets to the No operation Mode)

Standby Mode

Standby mode is activated when ADCCON [2] is set to '1'. In this mode, A/D conversion operation is halted and ADCDAT0, ADCDAT1 register contains the previous converted data.

Programming Notes

1. The A/D converted data can be accessed by means of interrupt or polling method. With interrupt method the overall conversion time - from A/D converter start to converted data read - may be delayed because of the return time of interrupt service routine and data access time. With polling method, by checking the ADCCON[15] - end of conversion flag-bit, the read time from ADCDAT register can be determined.
2. Another way for starting A/D conversion is provided. After ADCCON[1] - A/D conversion start-by-read mode-is set to 1, A/D conversion starts simultaneously whenever converted data is read.

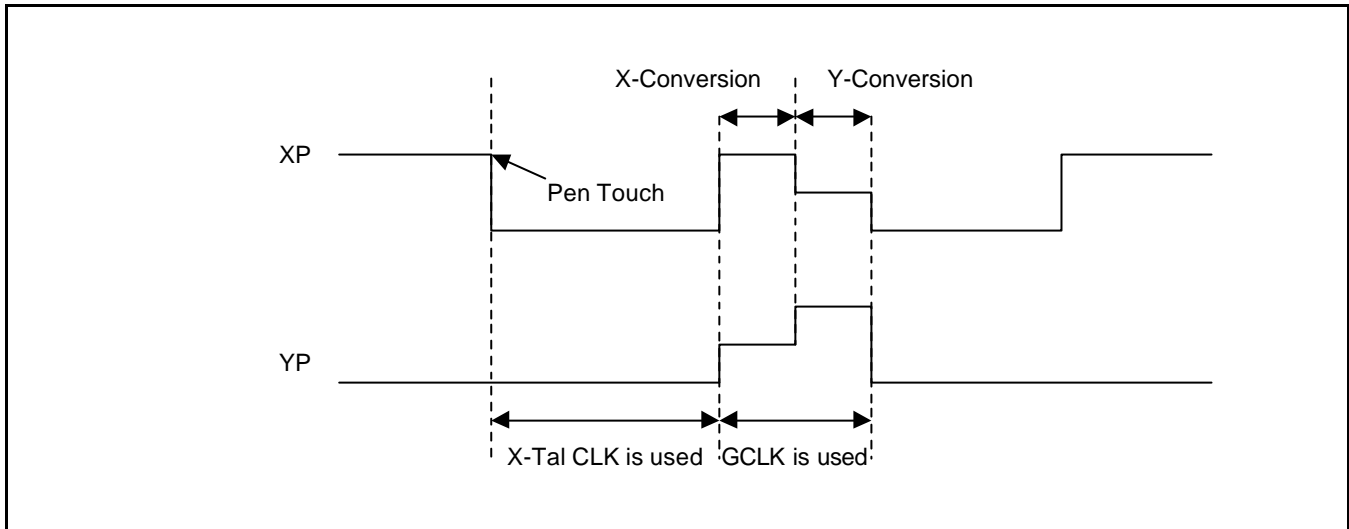

Figure 16-2. ADC and Touch Screen Operation signal

ADC AND TOUCH SCREEN INTERFACE SPECIAL REGISTERS

ADC CONTROL REGISTER (ADCCON)

Register	Address	R/W	Description	Reset Value
ADCCON	0x5800000	R/W	ADC control register	0x3FC4

ADCCON	Bit	Description	Initial State
ECFLG	[15]	End of conversion flag(Read only) 0 = A/D conversion in process 1 = End of A/D conversion	0
PRSCEN	[14]	A/D converter prescaler enable 0 = Disable 1 = Enable	0
PRSCVL	[13:6]	A/D converter prescaler value Data value: 0 ~ 255 NOTE: ADC Frequency should be set less than PCLK by 5times. (Ex. PCLK=10MHZ, ADC Freq.< 2MHz)	0xFF
SEL_MUX	[5:3]	Analog input channel select 000 = AIN 0 001 = AIN 1 010 = AIN 2 011 = AIN 3 100 = YM 101 = YP 110 = XM 111 = XP	0
STDBM	[2]	Standby mode select 0 = Normal operation mode 1 = Standby mode	1
READ_START	[1]	A/D conversion start by read 0 = Disable start by read operation 1 = Enable start by read operation	0
ENABLE_START	[0]	A/D conversion starts by enable. If READ_START is enabled, this value is not valid. 0 = No operation 1 = A/D conversion starts and this bit is cleared after the start-up.	0

NOTE: When Touch Screen Pads(YM, YP, XM, XP) are disabled, these ports can be used as Analog input ports(AIN4, AIN5, AIN6, AIN7) for ADC.

ADC TOUCH SCREEN CONTROL REGISTER (ADCTSC)

Register	Address	R/W	Description	Reset Value
ADCTSC	0x5800004	R/W	ADC Touch Screen Control Register	0x58

ADCTSC	Bit	Description	Initial State
UD_SEN	[8]	Detect Stylus Up or Down status. 0 = Detect Stylus Down Interrupt Signal. 1 = Detect Stylus Up Interrupt Signal.	0
YM_SEN	[7]	YM Switch Enable 0 = YM Output Driver Disable. 1 = YM Output Driver Enable.	0
YP_SEN	[6]	YP Switch Enable 0 = YP Output Driver Enable. 1 = YP Output Driver Disable.	1
XM_SEN	[5]	XM Switch Enable 0 = XM Output Driver Disable. 1 = XM Output Driver Enable.	0
XP_SEN	[4]	XP Switch Enable 0 = XP Output Driver Enable. 1 = XP Output Driver Disable.	1
PULL_UP	[3]	Pull-up Switch Enable 0 = XP Pull-up Enable. 1 = XP Pull-up Disable.	1
AUTO_PST	[2]	Automatically sequencing conversion of X-Position and Y-Position 0 = Normal ADC conversion. 1 = Auto Sequential measurement of X-position, Y-position.	0
XY_PST	[1:0]	Manually measurement of X-Position or Y-Position. 00 = No operation mode 01 = X-position measurement 10 = Y-position measurement 11 = Waiting for Interrupt Mode	0

NOTES:

- While waiting for Touch screen Interrupt, XP_SEN bit should be set to '1'(XP Output disable) and PULL_UP bit should be set to '0'(XP Pull-up enable).
- AUTO_PST bit should be set '1' only in Automatic & Sequential X/Y Position conversion.
- XP, YP should be disconnected with GND source during sleep mode to avoid leakage current. Because XP, YP will be maintained as 'H' states in sleep mode. Touch screen pin conditions in X/Y position conversion.

	XP	XM	YP	YM	ADC ch. select
X Position	Vref	GND	Hi-Z	Hi-Z	YP
Y Position	Hi-Z	Hi-Z	Vref	GND	XP

ADC START DELAY REGISTER (ADCDLY)

Register	Address	R/W	Description	Reset Value
ADCDLY	0x5800008	R/W	ADC Start or interval delay register	0x00ff

ADCDLY	Bit	Description	Initial State
DELAY	[15:0]	1) Normal Conversion Mode, XY position mode, auto position mode. → ADC conversion start delay value. 2) Waiting for Interrupt Mode. When stylus down occurs at SLEEP MODE, generates Wake-Up signal, having interval (several ms), for exiting SLEEP MODE. Note: Don't use Zero value (0x0000)	00ff

NOTE: Before ADC conversion, Touch screen uses X-tal clock (3.68MHz). During ADC conversion GCLK (Max. 50MHz) is used.

ADC CONVERSION DATA REGISTER (ADCDAT0)

Register	Address	R/W	Description	Reset Value
ADCDAT0	0x580000C	R	ADC conversion data register	–

ADCDAT0	Bit	Description	Initial State
UPDOWN	[15]	Up or Down state of stylus at waiting for interrupt mode. 0 = Stylus down state. 1 = Stylus up state.	–
AUTO_PST	[14]	Automatic sequencing conversion of X-position and Y-Position 0 = Normal ADC conversion. 1 = Sequencing measurement of X-position, Y-position.	–
XY_PST	[13:12]	Manually measurement of X-position or Y-position. 00 = No operation mode 01 = X-position measurement 10 = Y-position measurement 11 = Waiting for Interrupt Mode	–
Reserved	[11:10]	Reserved	–
XPDATA (Normal ADC)	[9:0]	X-Position conversion data value (include normal ADC conversion data value) Data value: 0 ~ 3FF	–

ADC CONVERSION DATA REGISTER (ADCDAT1)

Register	Address	R/W	Description	Reset Value
ADCDAT1	0x5800010	R	ADC conversion data register	–

ADCDAT1	Bit	Description	Initial State
UPDOWN	[15]	Up or down state of stylus at waiting for interrupt mode. 0 = Stylus down state. 1 = Stylus up state.	–
AUTO_PST	[14]	Automatically sequencing conversion of X-position and Y-position 0 = Normal ADC conversion. 1 = Sequencing measurement of X-position, Y-position.	–
XY_PST	[13:12]	Manually measurement of X-position or Y-position. 00 = No operation mode 01 = X-position measurement 10 = Y-position measurement 11 = Waiting for interrupt mode	–
Reserved	[11:10]	Reserved	–
Ypdata	[9:0]	Y-position conversion data value Data value: 0 ~ 3FF	–

ADC TOUCH SCREEN UP-DOWN INT CHECK REGISTER (ADCUPDN)

Register	Address	R/W	Description	Reset Value
ADCUPDN	0x5800014	R/W	Stylus up or down interrupt status register	0x0

ADCUPDN	Bit	Description	Initial State
TSC_UP	[1]	Stylus Up Interrupt. 0 = No stylus up status. 1 = Stylus up interrupt occurred.	0
TSC_DN	[0]	Stylus Down Interrupt. 0 = No stylus down status. 1 = Stylus down interrupt occurred.	0

NOTES

17 REAL TIME CLOCK

OVERVIEW

The Real Time Clock (RTC) unit can be operated by the backup battery while the system power is off. The RTC can transmit 8-bit data to CPU as Binary Coded Decimal (BCD) values using the STRB/LDRB ARM operation. The data include the time by second, minute, hour, date, day, month, and year. The RTC unit works with an external 32.768kHz crystal and also can perform the alarm function.

FEATURES

- BCD number: second, minute, hour, date, day, month, and year
- Leap year generator
- Alarm function: alarm interrupt or wake-up from power-off mode
- Year 2000 problem is removed.
- Independent power pin (RTCVDD)
- Supports millisecond tick time interrupt for RTOS kernel time tick.

REAL TIME CLOCK OPERATION

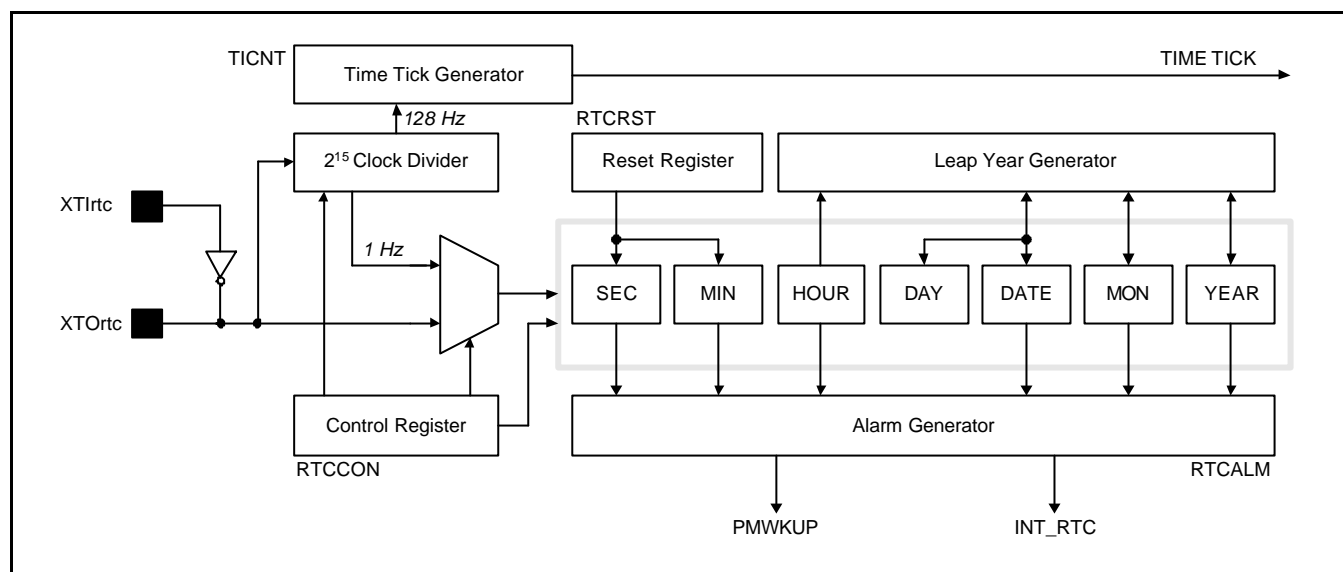

Figure 17-1. Real Time Clock Block Diagram

LEAP YEAR GENERATOR

The Leap Year Generator can determine the last date of each month out of 28, 29, 30, or 31, based on data from BCDDATE, BCDMON, and BCDYEAR. This block considers leap year in deciding on the last date. An 8-bit counter can only represent 2 BCD digits, so it cannot decide whether "00" year (the year with its last two digits zeros) is a leap year or not. For example, it cannot discriminate between 1900 and 2000. To solve this problem, the RTC block in S3C2440A has hard-wired logic to support the leap year in 2000. Note 1900 is not leap year while 2000 is leap year. Therefore, two digits of 00 in S3C2440A denote 2000, not 1900.

READ/WRITE REGISTERS

Bit 0 of the RTCCON register must be set high in order to write the BCD register in RTC block. To display the second, minute, hour, date, month, and year, the CPU should read the data in BCDSEC, BCDMIN, BCDHOUR, BCDDAY, BCDDATE, BCDMON, and BCDYEAR registers, respectively, in the RTC block. However, a one second deviation may exist because multiple registers are read. For example, when the user reads the registers from BCDYEAR to BCDMIN, the result is assumed to be 2059 (Year), 12 (Month), 31 (Date), 23 (Hour) and 59 (Minute). When the user read the BCDSEC register and the value ranges from 1 to 59 (Second), there is no problem, but, if the value is 0 sec., the year, month, date, hour, and minute may be changed to 2060 (Year), 1 (Month), 1 (Date), 0 (Hour) and 0 (Minute) because of the one second deviation that was mentioned. In this case, the user should re-read from BCDYEAR to BCDSEC if BCDSEC is zero.

BACKUP BATTERY OPERATION

The RTC logic can be driven by the backup battery, which supplies the power through the RTCVDD pin into the RTC block, even if the system power is off. When the system is off, the interfaces of the CPU and RTC logic should be blocked, and the backup battery only drives the oscillation circuit and the BCD counters to minimize power dissipation.

ALARM FUNCTION

The RTC generates an alarm signal at a specified time in the power-off mode or normal operation mode. In normal operation mode, the alarm interrupt (INT_RTC) is activated. In the power-off mode, the power management wakeup (PMWKUP) signal is activated as well as the INT_RTC. The RTC alarm register (RTCALM) determines the alarm enable/disable status and the condition of the alarm time setting.

TICK TIME INTERRUPT

The RTC tick time is used for interrupt request. The TICNT register has an interrupt enable bit and the count value for the interrupt. The count value reaches '0' when the tick time interrupt occurs. Then the period of interrupt is as follows:

- Period = (n+1) / 128 second
- n: Tick time count value (1~127)

This RTC time tick may be used for real time operating system (RTOS) kernel time tick. If time tick is generated by the RTC time tick, the time related function of RTOS will always synchronized in real time.

32.768KHZ X-TAL CONNECTION EXAMPLE

The Figure 17-2 shows a circuit of the RTC unit oscillation at 32.768Khz.

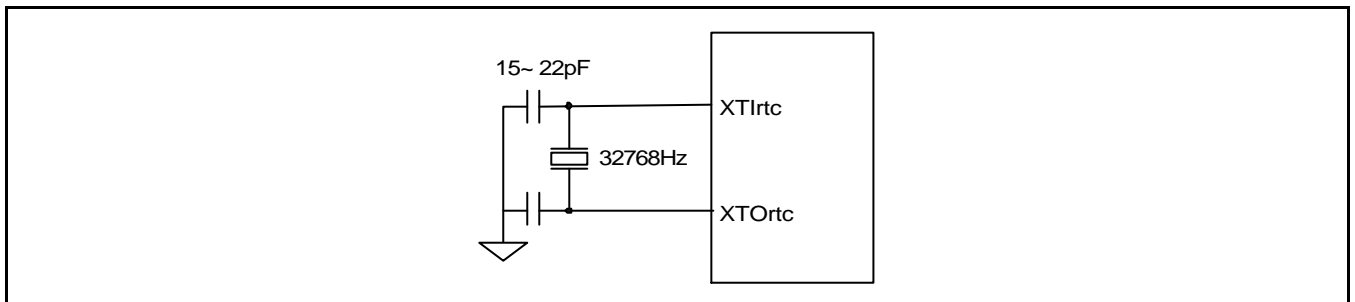

Figure 17-2. Main Oscillator Circuit Example

REAL TIME CLOCK SPECIAL REGISTERS

REAL TIME CLOCK CONTROL (RTCCON) REGISTER

The RTCCON register consists of 4 bits such as the RTCEN, which controls the read/write enable of the BCD registers, CLKSEL, CNTSEL, and CLKRST for testing.

RTCEN bit can control all interfaces between the CPU and the RTC, so it should be set to 1 in an RTC control routine to enable data read/write after a system reset. Also before power off, the RTCEN bit should be cleared to 0 to prevent inadvertent writing into RTC registers.

Register	Address	R/W	Description	Reset Value
RTCCON	0x57000040(L) 0x57000043(B)	R/W (by byte)	RTC control register	0x0

RTCCON	Bit	Description	Initial State
CLKRST	[3]	RTC clock count reset. 0 = No reset, 1 = Reset	0
CNTSEL	[2]	BCD count select. 0 = Merge BCD counters 1 = Reserved (Separate BCD counters)	0
CLKSEL	[1]	BCD clock select. 0 = XTAL 1/215 divided clock 1 = Reserved (XTAL clock only for test)	0
RTCEN	[0]	RTC control enable. 0 = Disable 1 = Enable Note: Only BCD time count and read operation can be performed.	0

NOTES:

- All RTC registers have to be accessed for each byte unit using STRB and LDRB instructions or char type pointer.
- (L): Little endian.
(B): Big endian.

TICK TIME COUNT (TICNT) REGISTER

Register	Address	R/W	Description	Reset Value
TICNT	0x57000044(L) 0x57000047(B)	R/W (by byte)	Tick time count register	0x0

TICNT	Bit	Description	Initial State
TICK INT Enable	[7]	Tick time interrupt enable. 0 = Disable 1 = Enable	0
TICK Time Count	[6:0]	Tick time count value (1~127). This counter value decreases internally, and users cannot read this counter value in working.	000000

RTC ALARM CONTROL (RTCALM) REGISTER

The RTCALM register determines the alarm enable and the alarm time. Please note that the RTCALM register generates the alarm signal through both INT_RTC and PMWKUP in power down mode, but only through INT_RTC in the normal operation mode.

Register	Address	R/W	Description	Reset Value
RTCALM	0x57000050(L) 0x57000053(B)	R/W (by byte)	RTC alarm control register	0x0

RTCALM	Bit	Description	Initial State
Reserved	[7]	–	0
ALMEN	[6]	Alarm global enable. 0 = Disable, 1 = Enable	0
YEAREN	[5]	Year alarm enable. 0 = Disable, 1 = Enable	0
MONREN	[4]	Month alarm enable. 0 = Disable, 1 = Enable	0
DATEEN	[3]	Date alarm enable. 0 = Disable, 1 = Enable	0
HOUREN	[2]	Hour alarm enable. 0 = Disable, 1 = Enable	0
MINEN	[1]	Minute alarm enable. 0 = Disable, 1 = Enable	0
SECEN	[0]	Second alarm enable. 0 = Disable, 1 = Enable	0

ALARM SECOND DATA (ALMSEC) REGISTER

Register	Address	R/W	Description	Reset Value
ALMSEC	0x57000054(L) 0x57000057(B)	R/W (by byte)	Alarm second data register	0x0

ALMSEC	Bit	Description	Initial State
Reserved	[7]	–	0
SECDATA	[6:4]	BCD value for alarm second. 0 ~ 5	000
	[3:0]	0 ~ 9	0000

ALARM MIN DATA (ALMMIN) REGISTER

Register	Address	R/W	Description	Reset Value
ALMMIN	0x57000058(L) 0x5700005B(B)	R/W (by byte)	Alarm minute data register	0x00

ALMMIN	Bit	Description	Initial State
Reserved	[7]	–	0
MINDATA	[6:4]	BCD value for alarm minute. 0 ~ 5	000
	[3:0]	0 ~ 9	0000

ALARM HOUR DATA (ALMHOUR) REGISTER

Register	Address	R/W	Description	Reset Value
ALMHOUR	0x5700005C(L) 0x5700005F(B)	R/W (by byte)	Alarm hour data register	0x0

ALMHOUR	Bit	Description	Initial State
Reserved	[7:6]	–	00
HOURDATA	[5:4]	BCD value for alarm hour. 0 ~ 2	00
	[3:0]	0 ~ 9	0000

ALARM DATE DATA (ALMDATE) REGISTER

Register	Address	R/W	Description	Reset Value
ALMDATE	0x57000060(L) 0x57000063(B)	R/W (by byte)	Alarm date data register	0x01

ALMDATE	Bit	Description	Initial State
Reserved	[7:6]	–	00
DATEDATA	[5:4]	BCD value for alarm date, from 0 to 28, 29, 30, 31. 0 ~ 3	00
	[3:0]	0 ~ 9	0001

ALARM MON DATA (ALMMON) REGISTER

Register	Address	R/W	Description	Reset Value
ALMMON	0x57000064(L) 0x57000067(B)	R/W (by byte)	Alarm month data register	0x01

ALMMON	Bit	Description	Initial State
Reserved	[7:5]	–	00
MONDATA	[4]	BCD value for alarm month. 0 ~ 1	0
	[3:0]	0 ~ 9	0001

ALARM YEAR DATA (ALMYEAR) REGISTER

Register	Address	R/W	Description	Reset Value
ALMYEAR	0x57000068(L) 0x5700006B(B)	R/W (by byte)	Alarm year data register	0x0

ALMYEAR	Bit	Description	Initial State
YEARDATA	[7:0]	BCD value for year. 00 ~ 99	0x0

BCD SECOND (BCDSEC) REGISTER

Register	Address	R/W	Description	Reset Value
BCDSEC	0x57000070(L) 0x57000073(B)	R/W (by byte)	BCD second register	Undefined

BCDSEC	Bit	Description	Initial State
SECDATA	[6:4]	BCD value for second. 0 ~ 5	–
	[3:0]	0 ~ 9	–

BCD MINUTE (BCDMIN) REGISTER

Register	Address	R/W	Description	Reset Value
BCDMIN	0x57000074(L) 0x57000077(B)	R/W (by byte)	BCD minute register	Undefined

BCDMIN	Bit	Description	Initial State
MINDATA	[6:4]	BCD value for minute. 0 ~ 5	–
	[3:0]	0 ~ 9	–

BCD HOUR (BCD HOUR) REGISTER

Register	Address	R/W	Description	Reset Value
BCD HOUR	0x57000078(L) 0x5700007B(B)	R/W (by byte)	BCD hour register	Undefined

BCD HOUR	Bit	Description	Initial State
Reserved	[7:6]	–	–
HOURDATA	[5:4]	BCD value for hour. 0 ~ 2	–
	[3:0]	0 ~ 9	–

BCD DATE (BCDDATE) REGISTER

Register	Address	R/W	Description	Reset Value
BCDDATE	0x5700007C(L) 0x5700007F(B)	R/W (by byte)	BCD date register	Undefined

BCDDATE	Bit	Description	Initial State
Reserved	[7:6]	–	–
DATEDATA	[5:4]	BCD value for date. 0 ~ 3	–
	[3:0]	0 ~ 9	–

BCD DAY (BCDDAY) REGISTER

Register	Address	R/W	Description	Reset Value
BCDDAY	0x57000080(L) 0x57000083(B)	R/W (by byte)	BCD a day of the week register	Undefined

BCDDAY	Bit	Description	Initial State
Reserved	[7:3]	–	–
DAYDATA	[2:0]	BCD value for a day of the week. 1 ~ 7	–

BCD MONTH (BCDMON) REGISTER

Register	Address	R/W	Description	Reset Value
BCDMON	0x57000084(L) 0x57000087(B)	R/W (by byte)	BCD month register	Undefined

BCDMON	Bit	Description	Initial State
Reserved	[7:5]	–	–
MONDATA	[4]	BCD value for month. 0 ~ 1	–
	[3:0]	0 ~ 9	–

BCD YEAR (BCDYEAR) REGISTER

Register	Address	R/W	Description	Reset Value
BCDYEAR	0x57000088(L) 0x5700008B(B)	R/W (by byte)	BCD year register	Undefined

BCDYEAR	Bit	Description	Initial State
YEARDATA	[7:0]	BCD value for year. 00 ~ 99	–

18

WATCHDOG TIMER

OVERVIEW

The S3C2440A watchdog timer is used to resume the controller operation whenever it is disturbed by malfunctions such as noise and system errors. It can be used as a normal 16-bit interval timer to request interrupt service. The watchdog timer generates the reset signal for 128 PCLK cycles.

FEATURES

- Normal interval timer mode with interrupt request
- Internal reset signal is activated for 128 PCLK cycles when the timer count value reaches 0 (time-out).

WATCHDOG TIMER OPERATION

Figure 18-1 shows the functional block diagram of the watchdog timer. The watchdog timer uses only PCLK as its source clock. The PCLK frequency is prescaled to generate the corresponding watchdog timer clock, and the resulting frequency is divided again.

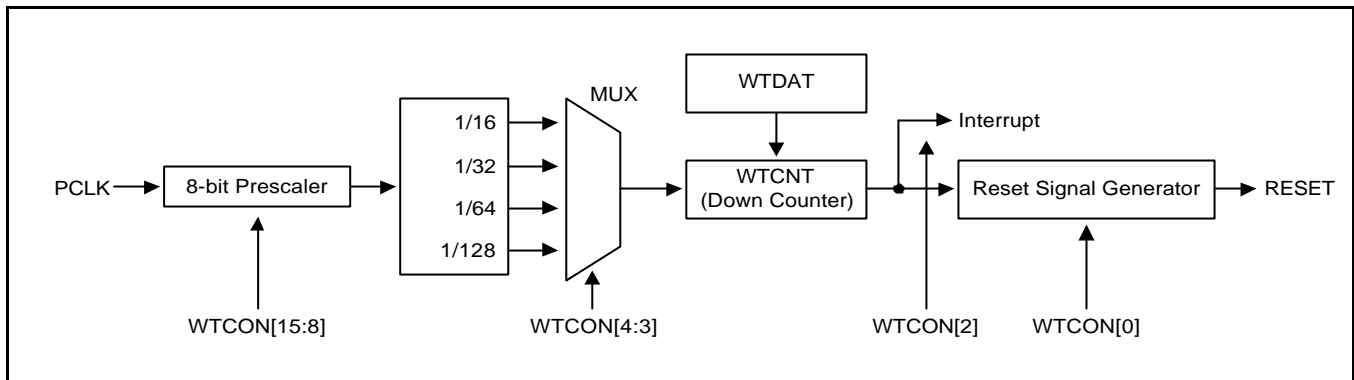

Figure 18-1. Watchdog Timer Block Diagram

The prescaler value and the frequency division factor are specified in the watchdog timer control (WTCON) register. Valid prescaler values range from 0 to 2^8-1 . The frequency division factor can be selected as 16, 32, 64, or 128.

Use the following equation to calculate the watchdog timer clock frequency and the duration of each timer clock cycle:

$$t_{\text{watchdog}} = 1 / [\text{PCLK} / (\text{Prescaler value} + 1) / \text{Division_factor}]$$

WTDAT & WTCNT

Once the watchdog timer is enabled, the value of watchdog timer data (WTDAT) register cannot be automatically reloaded into the timer counter (WTCNT). In this reason, an initial value must be written to the watchdog timer count (WTCNT) register, before the watchdog timer starts.

CONSIDERATION OF DEBUGGING ENVIRONMENT

When the S3C2440A is in debug mode using Embedded ICE, the watchdog timer must not operate.

The watchdog timer can determine whether or not it is currently in the debug mode from the CPU core signal (DBGACK signal). Once the DBGACK signal is asserted, the reset output of the watchdog timer is not activated as the watchdog timer is expired.

WATCHDOG TIMER SPECIAL REGISTERS

WATCHDOG TIMER CONTROL (WTCN) REGISTER

The WTCN register allows the user to enable/disable the watchdog timer, select the clock signal from 4 different sources, enable/disable interrupts, and enable/disable the watchdog timer output. The Watchdog timer is used to resume the S3C2440A restart on mal-function after its power on; if controller restart is not desired, the Watchdog timer should be disabled.

If the user wants to use the normal timer provided by the Watchdog timer, enable the interrupt and disable the Watchdog timer.

Register	Address	R/W	Description	Reset Value
WTCN	0x53000000	R/W	Watchdog timer control register	0x8021

WTCN	Bit	Description	Initial State
Prescaler value	[15:8]	Prescaler value. The valid range is from 0 to 255(2^8-1).	0x80
Reserved	[7:6]	Reserved. These two bits must be 00 in normal operation.	00
Watchdog timer	[5]	Enable or disable bit of Watchdog timer. 0 = Disable 1 = Enable	1
Clock select	[4:3]	Determine the clock division factor. 00: 16 01: 32 10: 64 11: 128	00
Interrupt generation	[2]	Enable or disable bit of the interrupt. 0 = Disable 1 = Enable	0
Reserved	[1]	Reserved. This bit must be 0 in normal operation.	0
Reset enable/disable	[0]	Enable or disable bit of Watchdog timer output for reset signal. 1: Assert reset signal of the S3C2440A at watchdog time-out 0: Disable the reset function of the watchdog timer.	1

WATCHDOG TIMER DATA (WTDAT) REGISTER

The WTDAT register is used to specify the time-out duration. The content of WTDAT cannot be automatically loaded into the timer counter at initial watchdog timer operation. However, using 0x8000 (initial value) will drive the first time-out. In this case, the value of WTDAT will be automatically reloaded into WTCNT.

Register	Address	R/W	Description	Reset Value
WTDAT	0x53000004	R/W	Watchdog timer data register	0x8000

WTDAT	Bit	Description	Initial State
Count reload value	[15:0]	Watchdog timer count value for reload.	0x8000

WATCHDOG TIMER COUNT (WTCNT) REGISTER

The WTCNT register contains the current count values for the watchdog timer during normal operation. Note that the content of the WTDAT register cannot be automatically loaded into the timer count register when the watchdog timer is enabled initially, so the WTCNT register must be set to an initial value before enabling it.

Register	Address	R/W	Description	Reset Value
WTCNT	0x53000008	R/W	Watchdog timer count register	0x8000

WTCNT	Bit	Description	Initial State
Count value	[15:0]	The current count value of the watchdog timer	0x8000

19

MMC/SD/SDIO CONTROLLER

FEATURES

- SD Memory Card Spec (ver 1.0) / MMC Spec(2.11) compatible
- SDIO Card Spec (Ver 1.0) compatible
- 16 words (64 bytes) FIFO for data Tx/Rx
- 40-bit Command Register
- 136-bit Response Register
- 8-bit Prescaler logic (Freq = System Clock/(P + 1))
- Normal, and DMA data transfer mode(byte, halfword, word transfer)
- DMA burst4 access support(only word transfer)
- 1-bit/4-bit (wide bus) mode & block/stream mode switch support

BLOCK DIAGRAM

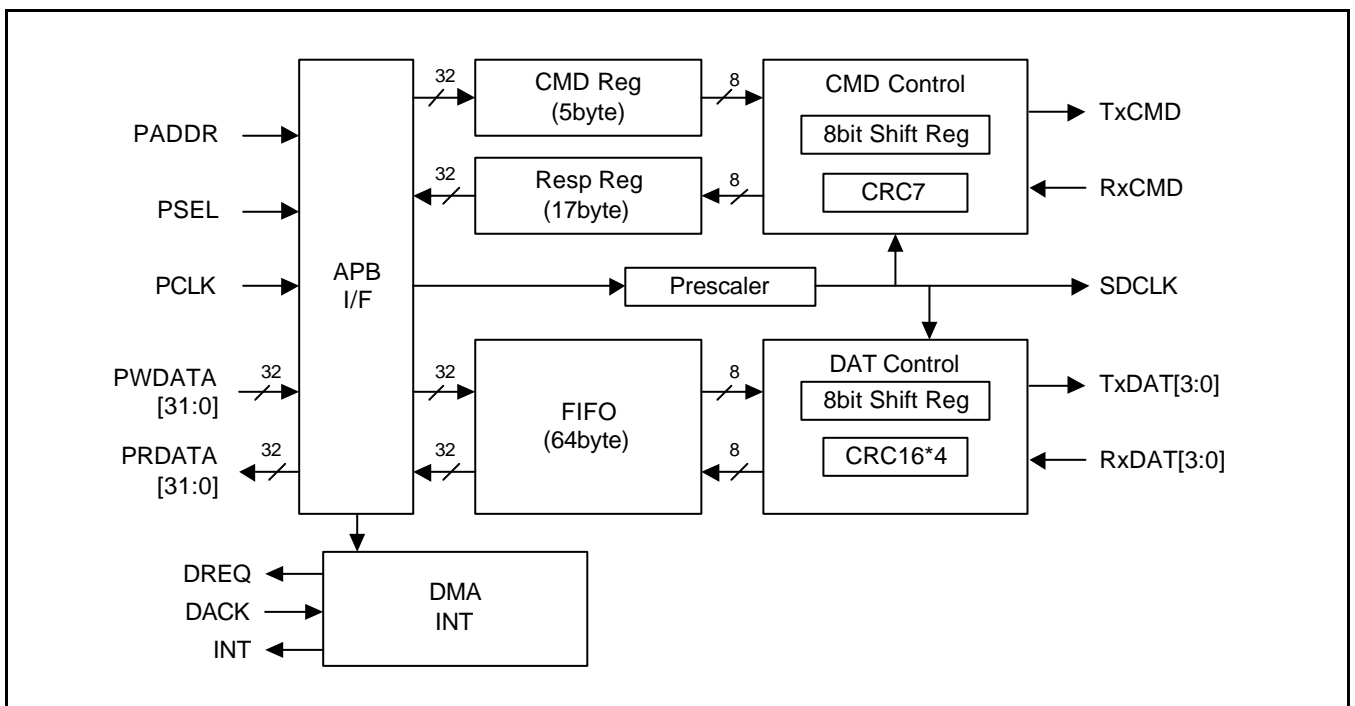

Figure 19-1. SD Interface block diagram

SD OPERATION

A serial clock line synchronizes shifting and sampling of the information on the five data lines. The transmission frequency is controlled by making the appropriate bit settings to the SDIPRE register. You can modify its frequency to adjust the baud rate data register value.

Programming Procedure (common)

To program the SDI modules, follow these basic steps:

1. Set SDICON to configure properly with clock & interrupt enable
2. Set SDIPRE to configure with a proper value.
3. Wait 74 SDCLK clock cycle in order to initialize the card.

CMD Path Programming

1. Write command argument 32bit to SDICmdArg.
2. Determine command types and start command transmit with setting SDICmdCon.
3. Confirm the end of SDI CMD path operation when the specific flag of SDICmdSta is set
4. The flag is CmdSent if command type is no response.
5. The flag is RspFin if command type is with response.
6. Clear the flags of SDICmdSta by writing '1' to the corresponding bit.

DAT Path Programming

1. Write data timeout period to SDIDTimer.
2. Write block size (block length) to SDIBSize (normally 0x80 word).
3. Determine the mode of block, wide bus, dma, etc and start data transfer with setting SDIDatCon.
4. Tx data → Write data to Data Register (SDIDAT) while Tx FIFO is available (TFDET is set), or half (TFHalf is set), or empty (TFEmpty is set).
5. Rx data → Read data from Data Register (SDIDAT) while Rx FIFO is available (RFDET is set), or full (RFFull is set), or half (RFHalf is set), or ready for last data (RFLast is set).
6. Confirm the end of SDI DAT path operation when DatFin flag of SDIDatSta is set
7. Clear the flags of SDIDatSta by writing '1' to the corresponding bit.

SDIO OPERATION

There are two functions of SDIO operation: SDIO Interrupt receiving and Read Wait Request generation. These two functions can operate when RcvIOInt bit and RwaitEn bit of SDICON register is activated respectively. And two functions have the steps and conditions like below.

SDIO Interrupt

In SD 1-bit mode, Interrupt is received through all range from RxDAT[1] pin.

In SD 4-bit mode, RxDAT[1] pin is shared between data receiving and interrupt receiving. When interrupt detection range(Interrupt Period) is:

1. Single Block: The time between A and B
 - A: 2clocks after the completion of a data packet
 - B: The completion of sending the end bit of the next withdata command
2. Multi Block, PrdType = 0: The time between A and B, restart at C
 - A: 2clocks after the completion of a data packet
 - B: 2clocks after A
 - C: 2clocks after the end bit of the abort command response
3. Multi Block, PrdType = 1: The time between A and B, restart at A
 - A: 2clocks after the completion of a data packet
 - B: 2clocks after A
 - In case of last block, interrupt period begins at A, but not ends at B (CMD53 case)

Read Wait Request

Regardless of 1bit or 4-bit mode, Read Wait Request signal transmits to TxDAT[2] pin in condition of below.

- In read multiple operation, request signal transmission begins at 2clocks after the end of the data block
- Transmission ends when user sets to one RwaitReq bit of SDIDatSta register

SDI SPECIAL REGISTERS

SDI Control Register (SDICON)

Register	Address	R/W	Description	Reset Value
SDICON	0x5A000000	R/W	SDI control register	0x0

SDICON	Bit	Description	Initial Value
Reserved	[31:9]	–	
SDMMC Reset (SDreset)	[8]	Reset whole sdmmc block. This bit is automatically cleared. 0 = Normal mode, 1 = SDMMC reset	0
Reserved	[7:6]		0
Clock Type (CTYP)	[5]	Determines which clock type is used as SDCLK. 0 = SD type, 1 = MMC type	0
Byte Order Type(ByteOrder)	[4]	Determines byte order type when you read(write) data from(to) sd host FIFO with word boundary. 0 = Type A, 1 = Type B	0
Receive SDIO Interrupt from card (RcvIOInt)	[3]	Determines whether sd host receives SDIO Interrupt from the card or not(for SDIO). 0 = Ignore, 1 = Receive SDIO Interrupt	0
Read Wait Enable(RWaitEn)	[2]	Determines read wait request signal generate when sd host waits the next block in multiple block read mode. This bit needs to delay the next block to be transmitted from the card(for SDIO). 0 = Disable(no generate), 1 = Read wait enable(use SDIO)	0
Reserved	[1]		
Clock Out Enable (ENCLK)	[0]	Determines whether SDCLK Out enable or not 0 = Disable (prescaler off), 1 = Clock enable	0

NOTE: Byte Order Type

Type A: (Access by Word) D[7:0] → D[15:8] → D[23:16] → D[31:24]

(Access by Halfword) D[7:0] → D[15:8]

Type B: (Access by Word) D[31:24] → D[23:16] → D[15:8] → D[7:0]

(Access by Halfword) D[15:8] → D[7:0]

SDI Baud Rate Prescaler Register (SDIPRE)

Register	Address	R/W	Description	Reset Value
SDIPRE	0x5A000004	R/W	SDI buad rate prescaler register	0x01

SDIPRE	Bit	Description	Initial Value
Prescaler Value	[7:0]	Determines SDI clock(SDCLK) rate as above equation. Baud rate = PCLK / (Prescaler value + 1)	0x01

NOTE: Prescaler Value should be greater than zero.

SDI Command Argument Register (SDICmdArg)

Register	Address	R/W	Description	Reset Value
SDICmdArg	0x5A000008	R/W	SDI command argument register	0x0

SDICmdArg	Bit	Description	Initial Value
CmdArg	[31:0]	Command argument	0x00000000

SDI Command Control Register (SDICmdCon)

Register	Address	R/W	Description	Reset Value
SDICmdCon	0x5A00000C	R/W	SDI command control register	0x0

SDICommand	Bit	Description	Initial Value
Reserved	[31:13]	–	
Abort Command (AbortCmd)	[12]	Determines whether command type is for abort (for SDIO). 0 = Normal command, 1 = Abort command (CMD12, CMD52)	0
Command with Data (WithData)	[11]	Determines whether command type is with data(for SDIO). 0 = Without data, 1 = With data	0
LongRsp	[10]	Determines whether host receives a 136-bit long response or not 0 = Short response, 1 = Long response	0
WaitRsp	[9]	Determines whether host waits for a response or not 0 = No response, 1 = Wait response	0
Command Start(CMST)	[8]	Determines whether command operation starts or not. . This bit is automatically cleared. 0 = Command ready, 1 = Command start	0
CmdIndex	[7:0]	Command index with start 2-bit (8-bit)	0x00

SDI Command Status Register (SDICmdSta)

Register	Address	R/W	Description	Reset Value
SDICmdSta	0x5A000010	R/(C)	SDI command status register	0x0

SDICmdSta	Bit	Description	Initial Value
Reserved	[31:13]	–	–
Response CRC Fail(RspCrc)	[12] R/C	CRC check failed when command response received. This flag is cleared by setting to one this bit. 0 = Not detect, 1 = CRC fail	0
Command Sent (CmdSent)	[11] R/C	Command sent(not concerned with response). This flag is cleared by setting to one this bit. 0 = Not detect, 1 = Command end	0
Command Time Out (CmdTout)	[10] R/C	Command response timeout (64CLK). This flag is cleared by setting to one this bit. 0 = Not detect, 1 = Timeout	0
Response Receive End (RspFin)	[9] R/C	Command response received. This flag is cleared by setting to one this bit. 0 = Not detect, 1 = Response end	0
CMD line progress On (CmdOn)	[8]	Command transfer in progress 0 = Not detect, 1 = In progress	0
RspIndex	[7:0]	Response index 6-bit with start 2-bit (8-bit)	0x00

SDI Response Register 0 (SDIRSP0)

Register	Address	R/W	Description	Reset Value
SDIRSP0	0x5A000014	R	SDI response register 0	0x0

SDIRSP0	Bit	Description	Initial Value
Response0	[31:0]	Card status[31:0](short), card status[127:96](long)	0x00000000

SDI Response Register 1 (SDIRSP1)

Register	Address	R/W	Description	Reset Value
SDIRSP1	0x5A000018	R	SDI response register 1	0x0

SDIRSP1	Bit	Description	Initial Value
RCRC7	[31:24]	CRC7(with end bit, short), card status[95:88](long)	0x00
Response1	[23:0]	unused(short), card status[87:64](long)	0x000000

SDI Response Register 2 (SDIRSP2)

Register	Address	R/W	Description	Reset Value
SDIRSP2	0x5A00001C	R	SDI Response Register 2	0x0

SDIRSP2	Bit	Description	Initial Value
Response2	[31:0]	unused(short), card status[63:32](long)	0x00000000

SDI Response Register 3 (SDIRSP3)

Register	Address	R/W	Description	Reset Value
SDIRSP3	0x5A000020	R	SDI response register 3	0x0

SDIRSP3	Bit	Description	Initial Value
Response3	[31:0]	unused(short), card status[31:0](long)	0x00000000

SDI Data / Busy Timer Register (SDIDTimer)

Register	Address	R/W	Description	Reset Value
SDIDTimer	0x5A000024	R/W	SDI data / busy timer register	0x0

SDIDTimer	Bit	Description	Initial Value
Reserved	[31:23]	–	–
DataTimer	[22:0]	Data / busy timeout period	0x10000

SDI Block Size Register (SDIBSize)

Register	Address	R/W	Description	Reset Value
SDIBSize	0x5A000028	R/W	SDI block size register	0x0

SDIBSize	Bit	Description	Initial Value
Reserved	[31:12]	–	–
BlkSize	[11:0]	Block size value (0~4095 byte), don't care when stream mode	0x000

NOTE: In Case of multi block, BlkSize must be aligned to word(4byte) size.(BlkSize[1:0] = 00)

SDI Data Control Register (SDIDatCon)

Register	Address	R/W	Description	Reset Value
SDIDatCon	0x5A00002C	R/W	SDI data control register	0x0

SDIDatCon	Bit	Description	Initial Value
Reserved	[31:25]	–	–
Burst4 enable (Burst4)	[24]	Enable Burst4 mode in DMA mode. This bit should be set only when Data Size is word. 0 = Disable, 1 = Burst4 enable	0
Data Size (DataSize)	[23:22]	Indicates the size of the transfer with FIFO, which is typically byte, halfword or word. 00 = Byte transfer, 01 = Halfword transfer 10 = Word transfer, 11 = Reserved	0
SDIO Interrupt Period Type (PrdType)	[21]	Determines whether SDIO Interrupt period is 2 cycle or extend more cycle when data block last is transferred (for SDIO). 0 = Exactly 2 cycle, 1 = More cycle (likely single block)	0
Transmit After Response (TARSP)	[20]	Determines when data transmit start after response receive or not 0 = Directly after DatMode set, 1 = After response receive (assume DatMode sets to 2'b11)	0
Receive After Command (RACMD)	[19]	Determines when data receive start after command sent or not 0 = Directly after DatMode set, 1 = After command sent (assume DatMode sets to 2'b10)	0
Busy After Command (BACMD)	[18]	Determines when busy receive start after command sent or not 0 = Directly after DatMode set, 1 = After command sent (assume DatMode sets to 2'b01)	0
Block mode (BlkMode)	[17]	Data transfer mode 0 = Stream data transfer, 1 = Block data transfer	0
Wide bus enable (WideBus)	[16]	Determines enable wide bus mode 0 = Standard bus mode(only SDIDAT[0] used), 1 = Wide bus mode(SDIDAT[3:0] used)	0
DMA Enable (EnDMA)	[15]	Enable DMA 0 = Disable(polling), 1 = Dma enable When DMA operation is completed, this bit should be disabled.	0
Data Transfer Start(DTST)	[14]	Determines whether data transfer start or not. . This bit is automatically cleared. 0 = Data ready, 1 = Data start	0
Data Transfer Mode (DatMode)	[13:12]	Determines which direction of data transfer 00 = No operation, 01 = Only busy check mode 10 = Data receive mode, 11 = Data transmit mode	00
BlkNum	[11:0]	Block Number (0~4095), don't care when stream mode	0x000

NOTE: If you want one of TARSP, RACMD, BACMD bits(SDIDatCon[20:18]) to "1", you need to write on SDIDatCon register ahead of on SDICmdCon register.(always need for SDIO)

SDI Data Remain Counter Register (ADIDatCnt)

Register	Address	R/W	Description	Reset Value
SDIDatCnt	0x5A000030	R	SDI data remain counter register	0x0

SDIDatCnt	Bit	Description	Initial Value
Reserved	[31:24]	–	–
BlkNumCnt	[23:12]	Remaining block number	0x000
BlkCnt	[11:0]	Remaining data byte of 1 block	0x000

SDI Data Status Register (ADIDatSta)

Register	Address	R/W	Description	Reset Value
SDIDatSta	0x5A000034	R/(C)	SDI data status register	0x0

SDIDatSta	Bit	Description	Initial Value
Reserved	[31:12]	–	–
No busy (NoBusy)	[11] R/C	Busy is not active during 16cycle after cmd packet transmitted in only busy check mode. This flag is cleared by setting to 1 this bit. 0 = Not detect, 1 = No busy signal	0
Read wait request occur (RWaitReq)	[10] R/C	Read wait request signal transmits to sd card. The request signal is stopped and this flag is cleared by setting to one this bit. 0 = Not occur, 1 = Read wait request occur	0
SDIO interrupt detect (IOIntDet)	[9] R/C	SDIO interrupt detect. This flag is cleared by setting to one this bit. 0 = Not detect, 1 = SDIO interrupt detect	0
Reserved	[8]	–	–
CRC status fail (CrcSta)	[7] R/C	CRC Status error when data block sent(CRC check failed). This flag is cleared by setting to one this bit. 0 = Not detect, 1 = Crc status fail	0
Data receive CRC fail (DatCrc)	[6] R/C	Data block received error(CRC check failed). This flag is cleared by setting to one this bit. 0 = Not detect, 1 = Receive crc fail	0
Data time out (DatTout)	[5] R/C	Data / Busy receive timeout. This flag is cleared by setting to one this bit. 0 = Not detect, 1 = Timeout	0
Data transfer finish (DatFin)	[4] R/C	Data transfer completes(data counter is zero). This flag is cleared by setting to one this bit. 0 = Not detect, 1 = Data finish detect	0
Busy finish (BusyFin)	[3] R/C	Only busy check finish. This flag is cleared by setting to one this bit 0 = Not detect, 1 = Busy finish detect	0
Reserved	[2]	–	–
Tx data progress on (TxDatOn)	[1]	Data transmit in progress 0 = Not active, 1 = Data Tx in progress	0
Rx data progress on (RxDatOn)	[0]	Data receive in progress 0 = Not active, 1 = Data Rx in progress	0

SDI Fifo Status Register (SDIFSTA)

Register	Address	R/W	Description	Reset Value
SDIFSTA	0x5A000038	R/(C)	SDI FIFO status register	0x0

SDIFSTA	Bit	Description	Initial State
Reserved	[31:16]	–	–
FIFO reset(FRST)	[16] C	Reset FIFO value. This bit is automatically cleared. 0 = Normal mode, 1 = FIFO reset	0
FIFO fail error (FFfail)	[15:14] R/C	FIFO fail error when FIFO occurs overrun / underrun data saving. This flag is cleared by setting to one these bits. 00 = Not detect, 01 = FIFO fail 10 = FIFO fail in the last transfer (only FIFO reset need) 11 = Reserved	0
FIFO available detect for Tx (TFDET)	[13]	This bit indicates that FIFO data is available for transmit when DatMode is data transmit mode. If DMA mode is enable, sd host requests DMA operation. 0 = Not detect(FIFO full), 1 = Detect ($0 \leq \text{FIFO} \leq 63$)	0
FIFO available detect for Rx (RFDET)	[12]	This bit indicates that FIFO data is available for receive when DatMode is data receive mode. If DMA mode is enable, sd host requests DMA operation. 0 = Not detect(FIFO empty), 1 = Detect ($1 \leq \text{FIFO} \leq 64$)	0
Tx FIFO half full (TFHalf)	[11]	This bit sets to 1 whenever Tx FIFO is less than 33byte. 0 = $33 \leq \text{Tx FIFO} \leq 64$, 1 = $0 \leq \text{Tx FIFO} \leq 32$	0
Tx FIFO empty (TFEmpty)	[10]	This bit sets to 1 whenever Tx FIFO is empty. 0 = $1 \leq \text{Tx FIFO} \leq 64$, 1 = Empty (0byte)	0
Rx FIFO last data ready (RFLast)	[9] R/C	This bit sets to 1 when Rx FIFO occurs to behave last data of all block. This flag is cleared by setting to one this bit. 0 = Not received yet, 1 = Rx FIFO gets Last data	0
Rx FIFO full (RFFull)	[8]	This bit sets to 1 whenever Rx FIFO is full. 0 = $0 \leq \text{Rx FIFO} \leq 63$, 1 = Full (64byte)	0
Rx FIFO half full (RFHalf)	[7]	This bit sets to 1 whenever Rx FIFO is more than 31byte. 0 = $0 \leq \text{Rx FIFO} \leq 31$, 1 = $32 \leq \text{Rx FIFO} \leq 64$	0
FIFO count (FFCNT)	[6:0]	Number of data(byte) in FIFO	0000000

NOTE: Although the last Rx data size is larger than remained count of FIFO data, you could read this data. If this event happens, you should clear FFail field, and FIFO reset field

SDI Interrupt Mask Register (SDIIntMsk)

Register	Address	R/W	Description	Reset Value
SDIIntMsk	0x5A00003C	R/W	SDI interrupt mask register	0x0

SDIIntMsk	Bit	Description	Initial Value
Reserved	[31:19]	–	–
NoBusy Interrupt Enable (NoBusyInt)	[18]	Determines SDI generate an interrupt if busy signal is not active 0 = Disable, 1 = Interrupt enable	0
RspCrc Interrupt Enable (RspCrcInt)	[17]	Determines SDI generate an interrupt if response CRC check fails 0 = Disable, 1 = Interrupt enable	0
CmdSent Interrupt Enable (CmdSentInt)	[16]	Determines SDI generate an interrupt if command sent(no response required) 0 = Disable, 1 = Interrupt enable	0
CmdTout Interrupt Enable (CmdToutInt)	[15]	Determines SDI generate an interrupt if command response timeout occurs 0 = Disable, 1 = Interrupt enable	0
RspEnd Interrupt Enable (RspEndInt)	[14]	Determines SDI generate an interrupt if command response received 0 = Disable, 1 = Interrupt enable	0
RWaitReq Interrupt Enable (RWaitReqInt)	[13]	Determines SDI generate an interrupt if read wait request occur. 0 = Disable, 1 = Interrupt enable	0
IOIntDet Interrupt Enable (IOIntDetInt)	[12]	Determines SDI generate an interrupt if sd host receives SDIO Interrupt from the card(for SDIO). 0 = Disable, 1 = Interrupt enable	0
FFfail Interrupt Enable (FFfailInt)	[11]	Determines SDI generate an interrupt if FIFO fail error occurs 0 = Disable, 1 = Interrupt enable	0
CrcSta Interrupt Enable (CrcStaInt)	[10]	Determines SDI generate an interrupt if CRC status error occurs 0 = Disable, 1 = Interrupt enable	0
DatCrc Interrupt Enable (DatCrcInt)	[9]	Determines SDI generate an interrupt if data receive CRC failed 0 = Disable, 1 = Interrupt enable	0
DatTout Interrupt Enable (DatToutInt)	[8]	Determines SDI generate an interrupt if data receive timeout occurs 0 = Disable, 1 = Interrupt enable	0
DatFin Interrupt Enable (DatFinInt)	[7]	Determines SDI generate an interrupt if data counter is zero 0 = Disable, 1 = Interrupt enable	0

SDI Interrupt Mask Register (SDIIntMsk) (Continued)

SDIIntMsk	Bit	Description	Initial Value
BusyFin Interrupt Enable (BusyFinInt)	[6]	Determines SDI generate an interrupt if only busy check completes 0 = Disable, 1 = Interrupt enable	0
Reserved	[5]	–	0
TFHalf Interrupt Enable (TFHalfInt)	[4]	Determines SDI generate an interrupt if Tx FIFO fills half 0 = Disable, 1 = Interrupt enable	0
TFFull Interrupt Enable (TFFullInt)	[3]	Determines SDI generate an interrupt if Tx FIFO is empty 0 = Disable, 1 = Interrupt enable	0
RFLast Interrupt Enable (RFLastInt)	[2]	Determines SDI generate an interrupt if Rx FIFO has last data 0 = Disable, 1 = Interrupt enable	0
RFFull Interrupt Enable (RFFullInt)	[1]	Determines SDI generate an interrupt if Rx FIFO fills full 0 = Disable, 1 = Interrupt enable	0
RFHalf Interrupt Enable (RFHalfInt)	[0]	Determines SDI generate an interrupt if Rx FIFO fills half 0 = Disable, 1 = Interrupt enable	0

SDI Data Register (SDIDAT)

Register	Address	R/W	Description	Reset Value
SDIDAT	0x5A000040, 44, 48, 4C(Li/W, Li/HW, Li/B, Bi/W) 0x5A000041(Bi/HW), 0x5A000043(Bi/B)	R/W	SDI data register	0x0

SDIDAT	Bit	Description	Initial State
Data Register	[31:0]	This field contains the data to be transmitted or received over the SDI channel	0x00000000

NOTE:

- (Li/W, Li/HW, Li/B): Access by Word/HalfWord/Byte unit when endian mode is Little
- (Bi/W): Access by Word unit when endian mode is Big
- (Bi/HW): Access by HalfWord unit when endian mode is Big
- (Bi/B): Access by Byte unit when endian mode is Big

20 IIC-BUS INTERFACE

OVERVIEW

The S3C2440A RISC microprocessor can support a multi-master IIC-bus serial interface. A dedicated serial data line (SDA) and a serial clock line (SCL) carry information between bus masters and peripheral devices which are connected to the IIC-bus. The SDA and SCL lines are bi-directional.

In multi-master IIC-bus mode, multiple S3C2440A RISC microprocessors can receive or transmit serial data to or from slave devices. The master S3C2440A can initiate and terminate a data transfer over the IIC-bus. The IIC-bus in the S3C2440A uses Standard bus arbitration procedure.

To control multi-master IIC-bus operations, values must be written to the following registers:

- Multi-master IIC-bus control register, IICCON
- Multi-master IIC-bus control/status register, IICSTAT
- Multi-master IIC-bus Tx/Rx data shift register, IICDS
- Multi-master IIC-bus address register, IICADD

When the IIC-bus is free, the SDA and SCL lines should be both at High level. A High-to-Low transition of SDA can initiate a Start condition. A Low-to-High transition of SDA can initiate a Stop condition while SCL remains steady at High Level.

The Start and Stop conditions can always be generated by the master devices. A 7-bit address value in the first data byte, which is put onto the bus after the Start condition has been initiated, can determine the slave device which the bus master device has selected. The 8th bit determines the direction of the transfer (read or write).

Every data byte put onto the SDA line should be eight bits in total. The bytes can be unlimitedly sent or received during the bus transfer operation. Data is always sent from most-significant bit (MSB) first, and every byte should be immediately followed by acknowledge (ACK) bit.

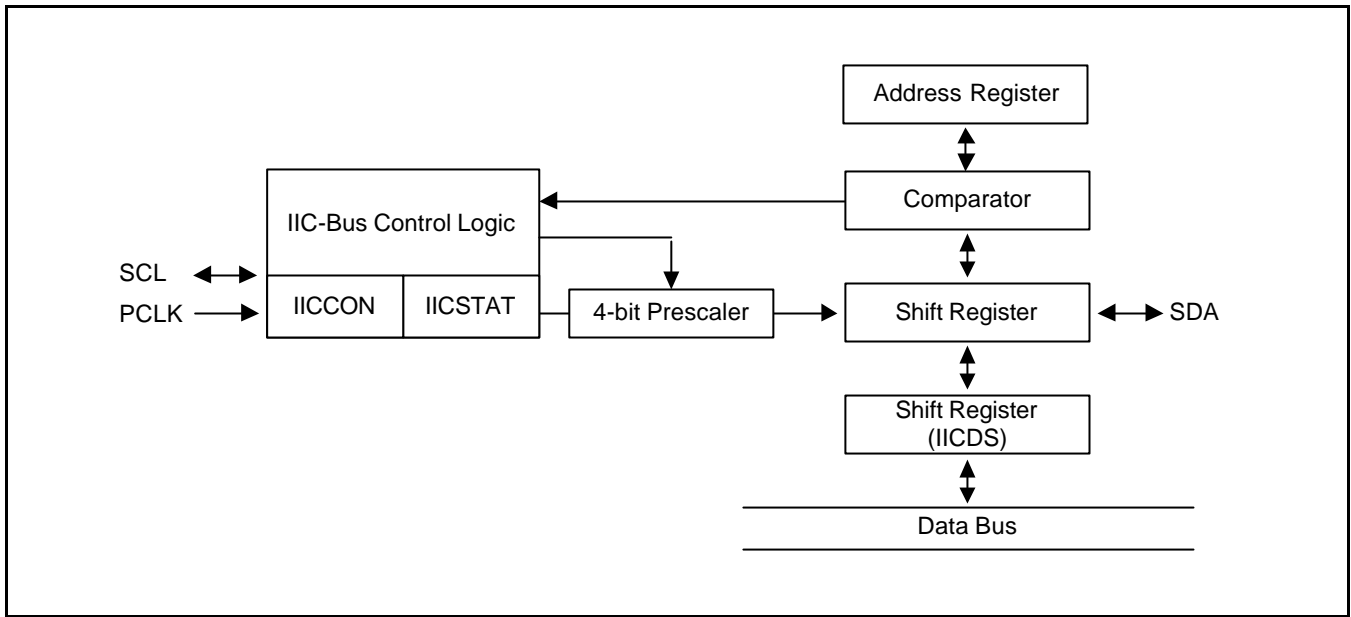

Figure 20-1. IIC-Bus Block Diagram

IIC-BUS INTERFACE

The S3C2440A IIC-bus interface has four operation modes:

- Master transmitter mode
- Master receive mode
- Slave transmitter mode
- Slave receive mode

Functional relationships among these operating modes are described below.

START AND STOP CONDITIONS

When the IIC-bus interface is inactive, it is usually in Slave mode. In other words, the interface should be in Slave mode before detecting a Start condition on the SDA line (a Start condition can be initiated with a High-to-Low transition of the SDA line while the clock signal of SCL is High). When the interface state is changed to Master mode, a data transfer on the SDA line can be initiated and SCL signal generated.

A Start condition can transfer a one-byte serial data over the SDA line, and a Stop condition can terminate the data transfer. A Stop condition is a Low-to-High transition of the SDA line while SCL is High. Start and Stop conditions are always generated by the master. The IIC-bus gets busy when a Start condition is generated. A Stop condition will make the IIC-bus free.

When a master initiates a Start condition, it should send a slave address to notify the slave device. One byte of address field consists of a 7-bit address and a 1-bit transfer direction indicator (showing write or read). If bit 8 is 0, it indicates a write operation (transmit operation); if bit 8 is 1, it indicates a request for data read (receive operation).

The master will complete the transfer operation by transmitting a Stop condition. If the master wants to continue the data transmission to the bus, it should generate another Start condition as well as a slave address. In this way, the read-write operation can be performed in various formats.

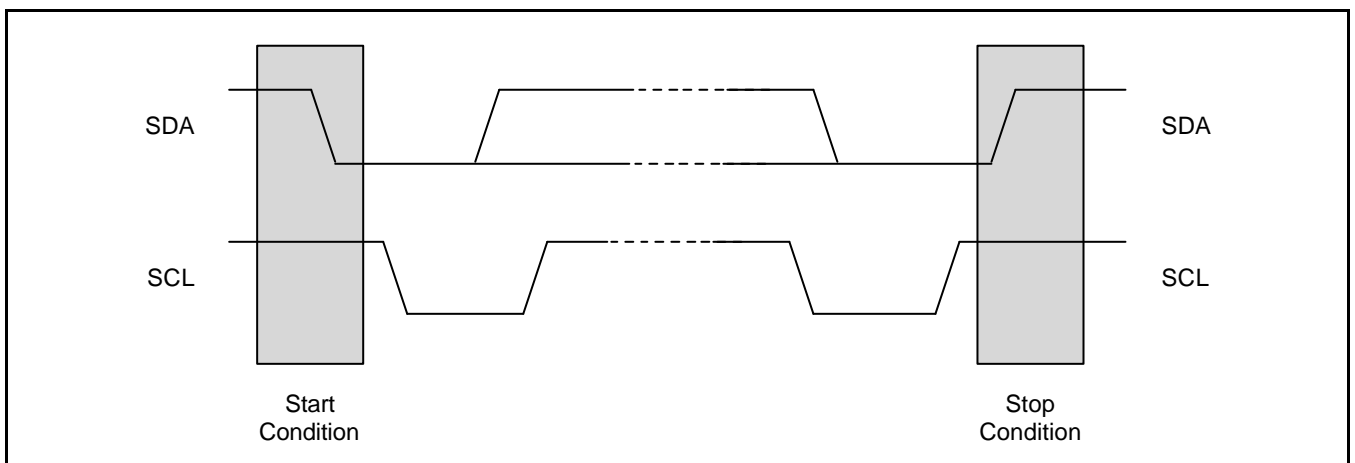

Figure 20-2. Start and Stop Condition

DATA TRANSFER FORMAT

Every byte placed on the SDA line should be eight bits in length. The bytes can be unlimitedly transmitted per transfer. The first byte following a Start condition should have the address field. The address field can be transmitted by the master when the IIC-bus is operating in Master mode. Each byte should be followed by an acknowledgement (ACK) bit. The MSB bit of the serial data and addresses are always sent first.

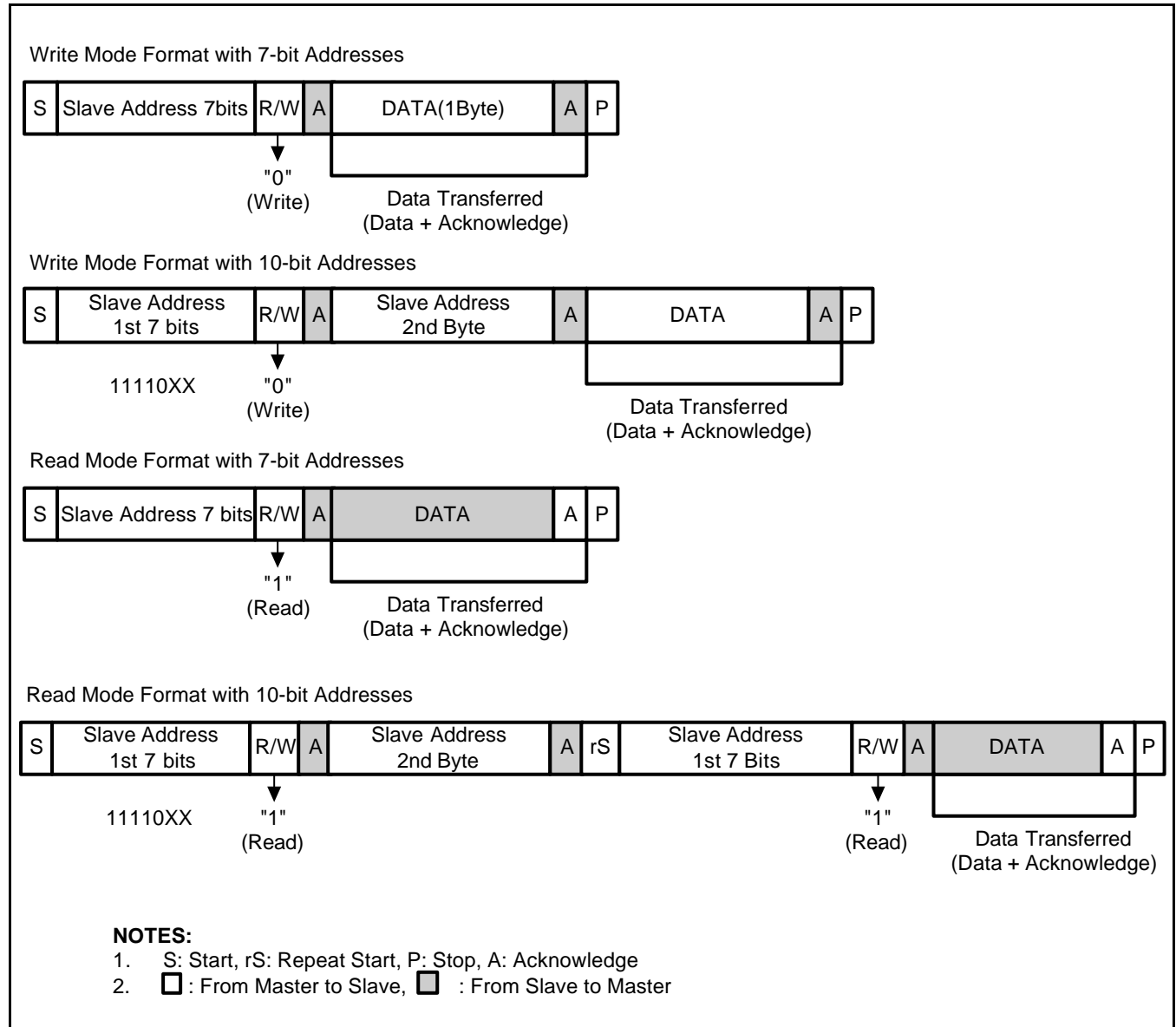

Figure 20-3. IIC-Bus Interface Data Format

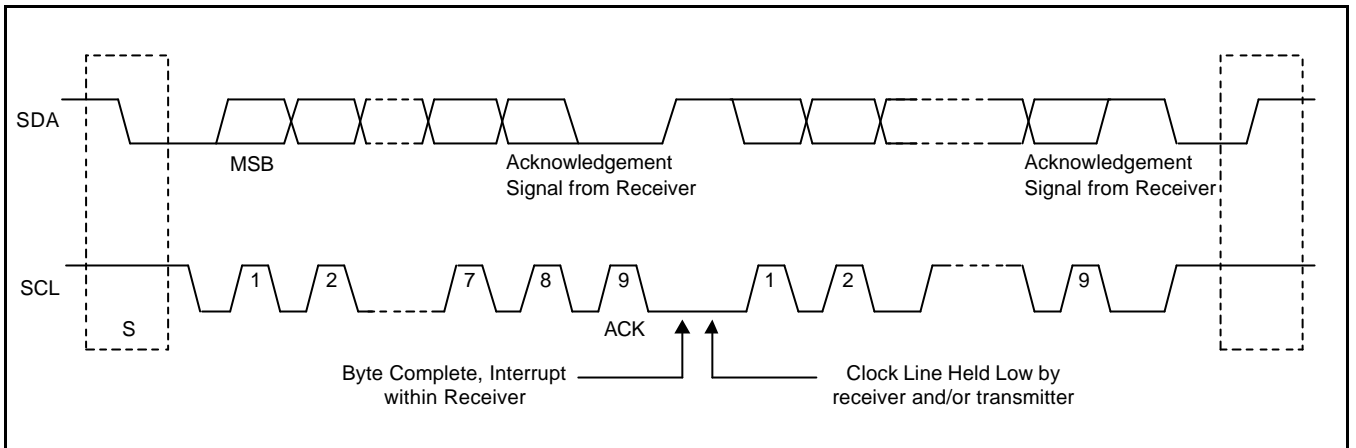

Figure 20-4. Data Transfer on the IIC-Bus

ACK SIGNAL TRANSMISSION

To complete a one-byte transfer operation, the receiver should send an ACK bit to the transmitter. The ACK pulse should occur at the ninth clock of the SCL line. Eight clocks are required for the one-byte data transfer. The master should generate the clock pulse required to transmit the ACK bit.

The transmitter should release the SDA line by making the SDA line High when the ACK clock pulse is received. The receiver should also drive the SDA line Low during the ACK clock pulse so that the SDA keeps Low during the High period of the ninth SCL pulse.

The ACK bit transmit function can be enabled or disabled by software (IICSTAT). However, the ACK pulse on the ninth clock of SCL is required to complete the one-byte data transfer operation.

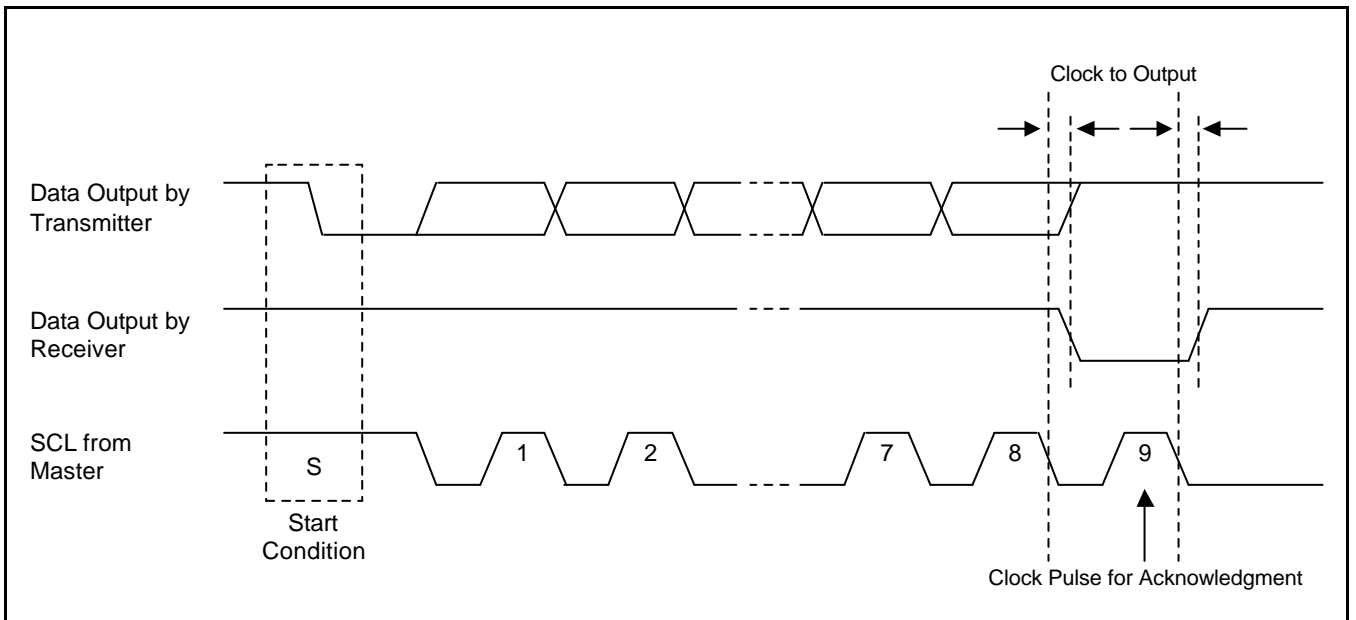

Figure 20-5. Acknowledge on the IIC-Bus

READ-WRITE OPERATION

In Transmitter mode, when the data is transferred, the IIC-bus interface will wait until IIC-bus Data Shift (IICDS) register receives a new data. Before the new data is written into the register, the SCL line will be held low, and then released after it is written. The S3C2440A should hold the interrupt to identify the completion of current data transfer. After the CPU receives the interrupt request, it should write a new data into the IICDS register, again.

In Receive mode, when data is received, the IIC-bus interface will wait until IICDS register is read. Before the new data is read out, the SCL line will be held low and then released after it is read. The S3C2440A should hold the interrupt to identify the completion of the new data reception. After the CPU receives the interrupt request, it should read the data from the IICDS register.

BUS ARBITRATION PROCEDURES

Arbitration takes place on the SDA line to prevent the contention on the bus between two masters. If a master with a SDA High level detects the other master with a SDA active Low level, it will not initiate a data transfer because the current level on the bus does not correspond to its own. The arbitration procedure will be extended until the SDA line turns High.

However, when the masters simultaneously lower the SDA line, each master should evaluate whether the mastership is allocated itself or not. For the purpose of evaluation is that each master should detect the address bits. While each master generates the slaver address, it should also detect the address bit on the SDA line because the SDA line is likely to get Low rather than to keep High. Assume that one master generates a Low as first address bit, while the other master is maintaining High. In this case, both masters will detect Low on the bus because the Low status is superior to the High status in power. When this happens, Low (as the first bit of address) generating master will get the mastership while High (as the first bit of address) generating master should withdraw the mastership. If both masters generate Low as the first bit of address, there should be arbitration for the second address bit, again. This arbitration will continue to the end of last address bit.

ABORT CONDITIONS

If a slave receiver cannot acknowledge the confirmation of the slave address, it should hold the level of the SDA line High. In this case, the master should generate a Stop condition and to abort the transfer.

If a master receiver is involved in the aborted transfer, it should signal the end of the slave transmit operation by canceling the generation of an ACK after the last data byte received from the slave. The slave transmitter should then release the SDA to allow a master to generate a Stop condition.

CONFIGURING IIC-BUS

To control the frequency of the serial clock (SCL), the 4-bit prescaler value can be programmed in the IICCON register. The IIC-bus interface address is stored in the IIC-bus address (IICADD) register. (By default, the IIC-bus interface address has an unknown value.)

FLOWCHARTS OF OPERATIONS IN EACH MODE

The following steps must be executed before any IIC Tx/Rx operations.

1. Write own slave address on IICADD register, if needed.
2. Set IICCON register.
 - a) Enable interrupt
 - b) Define SCL period
3. Set IICSTAT to enable Serial Output

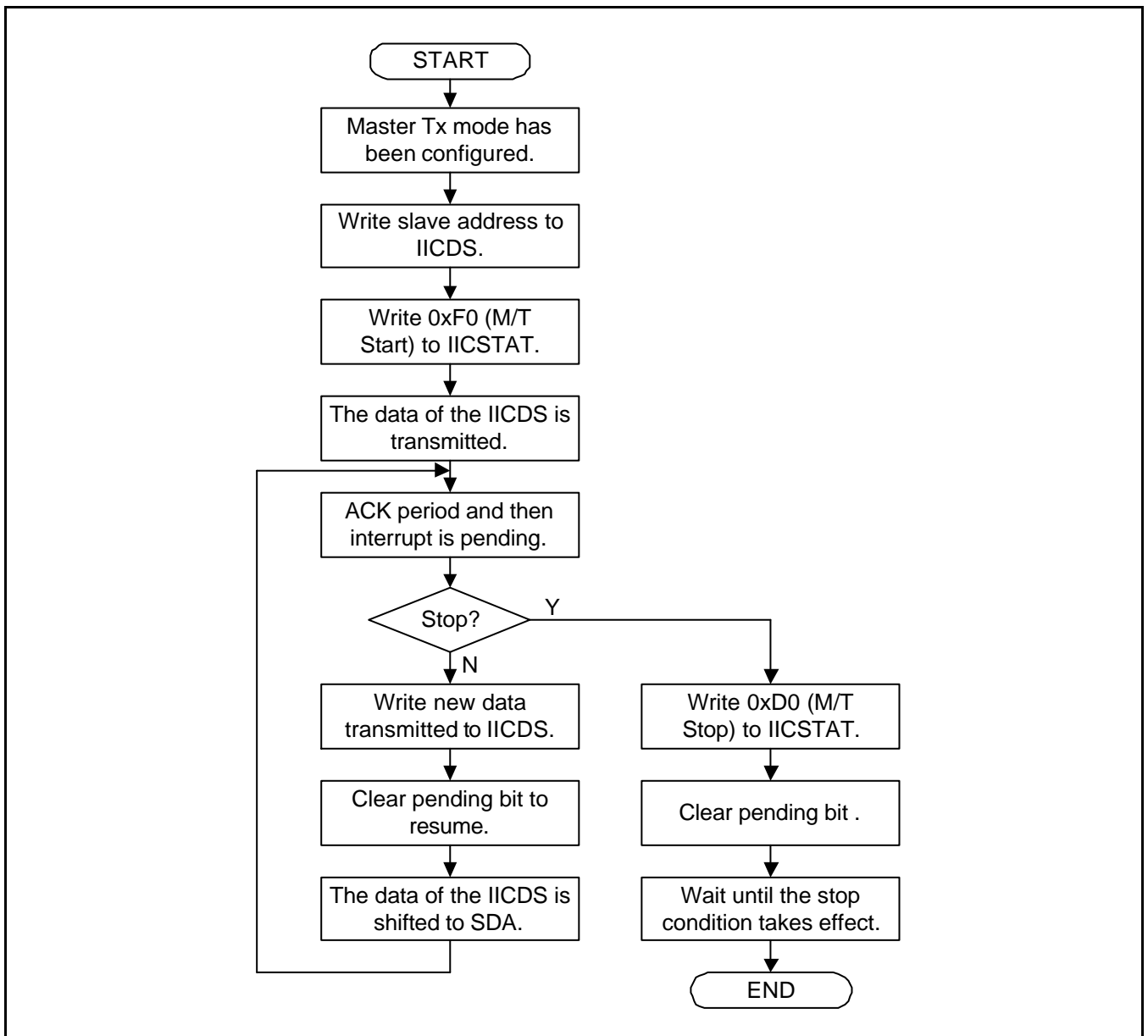

Figure 20-6. Operations for Master/Transmitter Mode

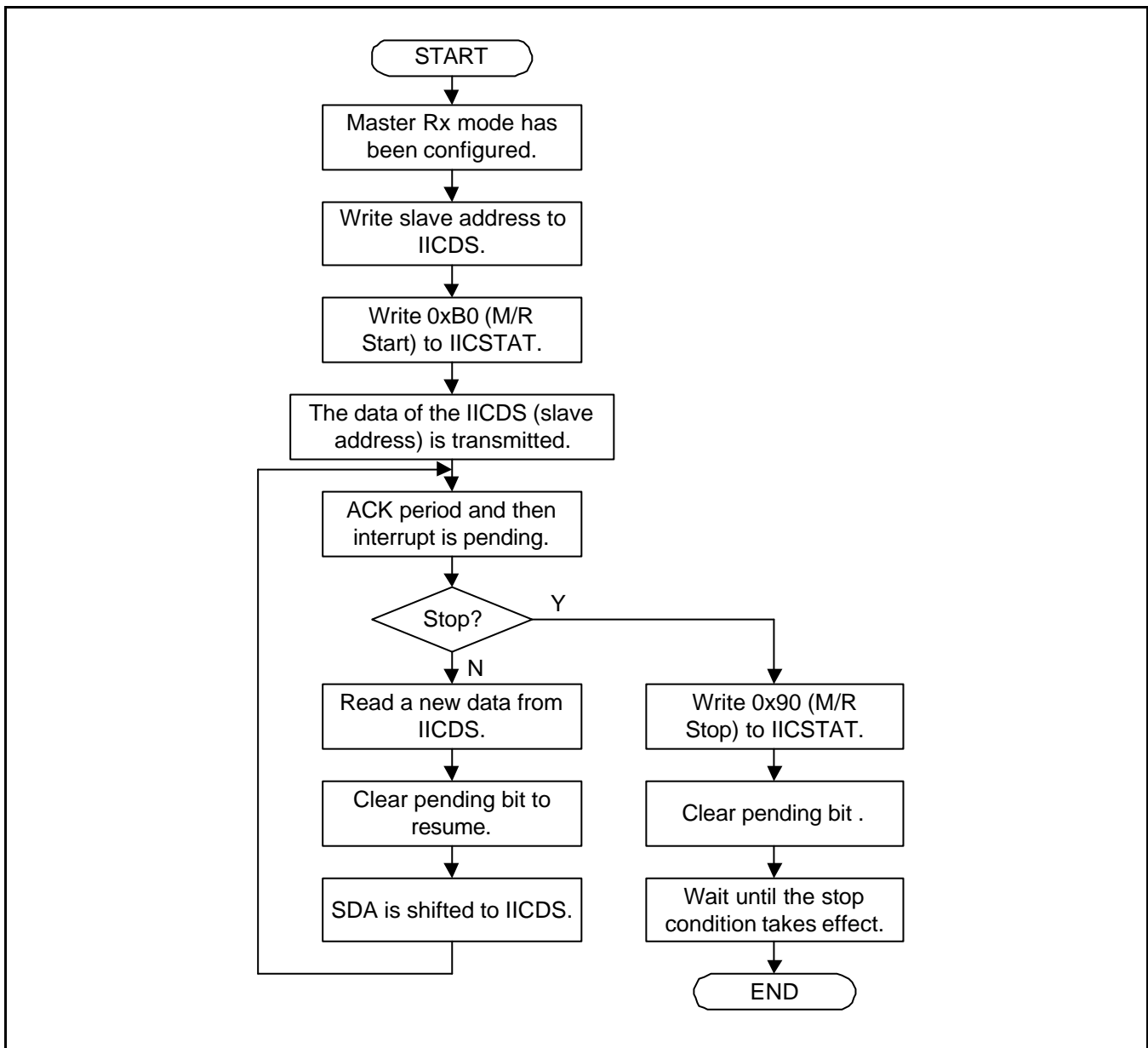

Figure 20-7. Operations for Master/Receiver Mode

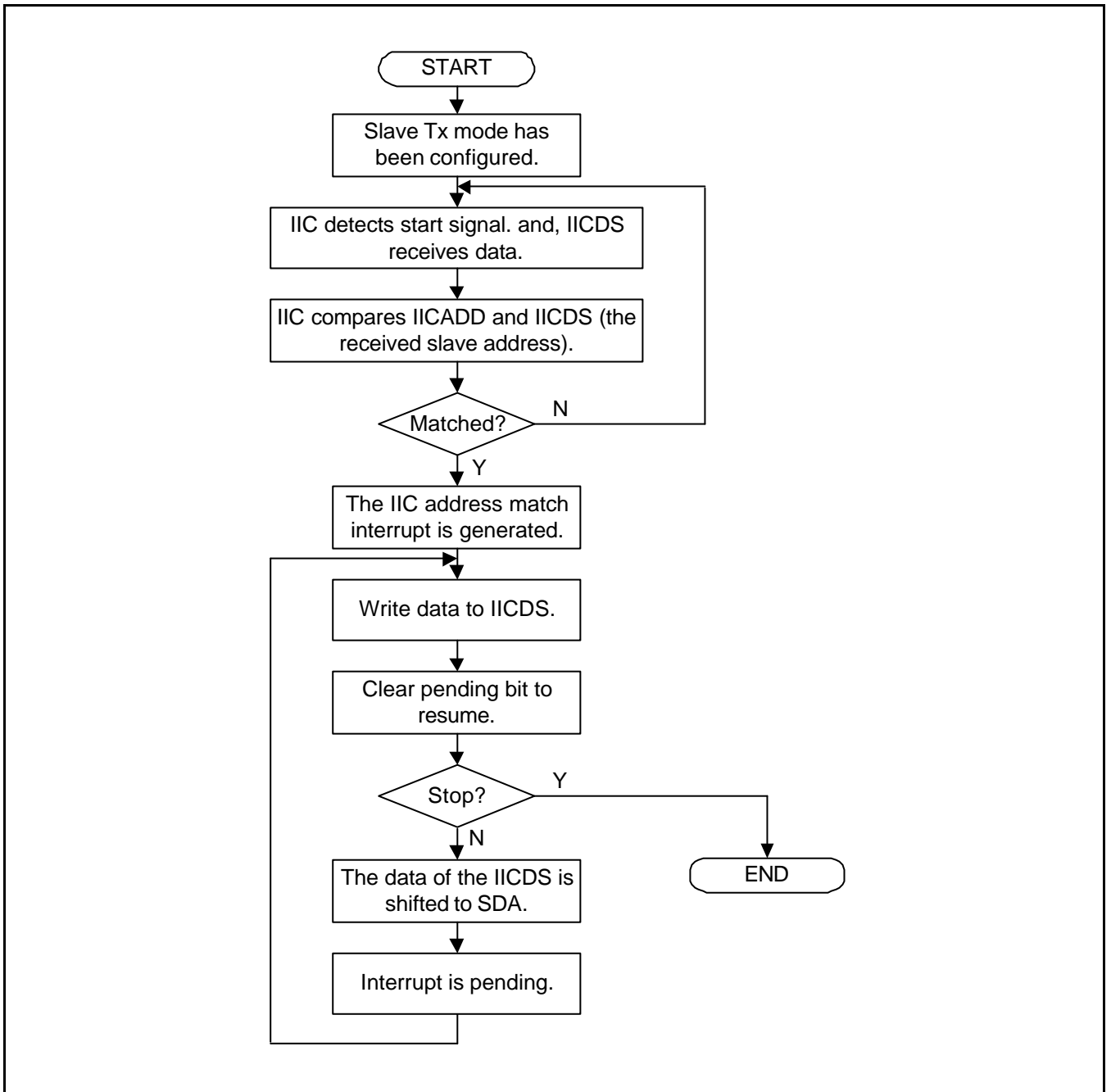

Figure 20-8. Operations for Slave/Transmitter Mode

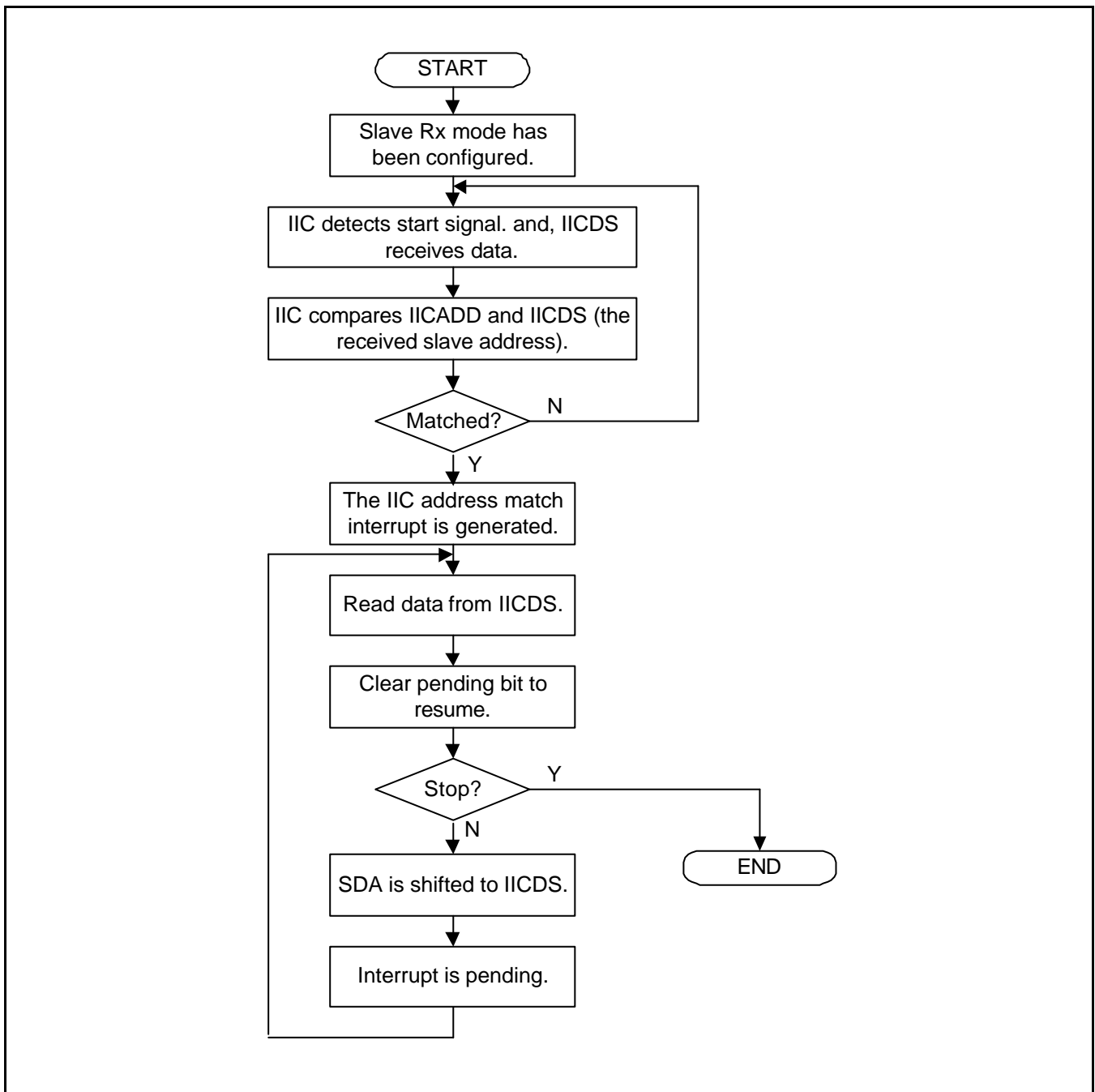

Figure 20-9. Operations for Slave/Receiver Mode

IIC-BUS INTERFACE SPECIAL REGISTERS

MULTI-MASTER IIC-BUS CONTROL (IICCON) REGISTER

Register	Address	R/W	Description	Reset Value
IICCON	0x54000000	R/W	IIC-Bus control register	0x0X

IICCON	Bit	Description	Initial State
Acknowledge generation ⁽¹⁾	[7]	IIC-bus acknowledge enable bit. 0: Disable 1: Enable In Tx mode, the IICSDA is free in the ack time. In Rx mode, the IICSDA is L in the ack time.	0
Tx clock source selection	[6]	Source clock of IIC-bus transmit clock prescaler selection bit. 0: IICCLK = fPCLK /16 1: IICCLK = fPCLK /512	0
Tx/Rx Interrupt ⁽⁵⁾	[5]	IIC-Bus Tx/Rx interrupt enable/disable bit. 0: Disable, 1: Enable	0
Interrupt pending flag ^{(2) (3)}	[4]	IIC-bus Tx/Rx interrupt pending flag. This bit cannot be written to 1. When this bit is read as 1, the IIC_SCL is tied to L and the IIC is stopped. To resume the operation, clear this bit as 0. 0: 1) No interrupt pending (when read). 2) Clear pending condition & Resume the operation (when write). 1: 1) Interrupt is pending (when read) 2) N/A (when write)	0
Transmit clock value ⁽⁴⁾	[3:0]	IIC-Bus transmit clock prescaler. IIC-Bus transmit clock frequency is determined by this 4-bit prescaler value, according to the following formula: Tx clock = IICCLK/(IICCON[3:0]+1).	Undefined

NOTES:

- Interfacing with EEPROM, the ack generation may be disabled before reading the last data in order to generate the STOP condition in Rx mode.
- An IIC-bus interrupt occurs 1) when a 1-byte transmits or receive operation is completed, 2) when a general call or a slave address match occurs, or 3) if bus arbitration fails.
- To adjust the setup time of SDA before SCL rising edge, IICDS has to be written before clearing the IIC interrupt pending bit.
- IICCLK is determined by IICCON[6].
Tx clock can vary by SCL transition time.
When IICCON[6]=0, IICCON[3:0]=0x0 or 0x1 is not available.
- If the IICCON[5]=0, IICCON[4] does not operate correctly.
So, It is recommended that you should set IICCON[5]=1, although you does not use the IIC interrupt.

MULTI-MASTER IIC-BUS CONTROL/STATUS (IICSTAT) REGISTER

Register	Address	R/W	Description	Reset Value
IICSTAT	0x54000004	R/W	IIC-Bus control/status register	0x0

IICSTAT	Bit	Description	Initial State
Mode selection	[7:6]	IIC-bus master/slave Tx/Rx mode select bits. 00: Slave receive mode 01: Slave transmit mode 10: Master receive mode 11: Master transmit mode	00
Busy signal status / START STOP condition	[5]	IIC-Bus busy signal status bit. 0: read) Not busy (when read) write) STOP signal generation 1: read) Busy (when read) write) START signal generation. The data in IICDS will be transferred automatically just after the start signal.	0
Serial output	[4]	IIC-bus data output enable/disable bit. 0: Disable Rx/Tx, 1: Enable Rx/Tx	0
Arbitration status flag	[3]	IIC-bus arbitration procedure status flag bit. 0: Bus arbitration successful 1: Bus arbitration failed during serial I/O	0
Address-as-slave status flag	[2]	IIC-bus address-as-slave status flag bit. 0: Cleared when START/STOP condition was detected 1: Received slave address matches the address value in the IICADD	0
Address zero status flag	[1]	IIC-bus address zero status flag bit. 0: Cleared when START/STOP condition was detected 1: Received slave address is 00000000b.	0
Last-received bit status flag	[0]	IIC-bus last-received bit status flag bit. 0: Last-received bit is 0 (ACK was received). 1: Last-received bit is 1 (ACK was not received).	0

MULTI-MASTER IIC-BUS ADDRESS (IICADD) REGISTER

Register	Address	R/W	Description	Reset Value
IICADD	0x54000008	R/W	IIC-Bus address register	0xXX

IICADD	Bit	Description	Initial State
Slave address	[7:0]	7-bit slave address, latched from the IIC-bus. When serial output enable = 0 in the IICSTAT, IICADD is write-enabled. The IICADD value can be read any time, regardless of the current serial output enable bit (IICSTAT) setting. Slave address : [7:1] Not mapped : [0]	XXXXXXXX

MULTI-MASTER IIC-BUS TRANSMIT/RECEIVE DATA SHIFT (IICDS) REGISTER

Register	Address	R/W	Description	Reset Value
IICDS	0x5400000C	R/W	IIC-Bus transmit/receive data shift register	0xXX

IICDS	Bit	Description	Initial State
Data shift	[7:0]	8-bit data shift register for IIC-bus Tx/Rx operation. When serial output enable = 1 in the IICSTAT, IICDS is write-enabled. The IICDS value can be read any time, regardless of the current serial output enable bit (IICSTAT) setting.	XXXXXXXX

MULTI-MASTER IIC-BUS LINE CONTROL(IICLC) REGISTER

Register	Address	R/W	Description	Reset Value
IICLC	0x54000010	R/W	IIC-Bus multi-master line control register	0x00

IICLC	Bit	Description	Initial State
Filter enable	[2]	IIC-bus filter enable bit. When SDA port is operating as input, this bit should be High. This filter can prevent from occurred error by a glitch during double of PCLK time. 0: Filter disable 1: Filter enable	0
SDA output delay	[1:0]	IIC-Bus SDA line delay length selection bits. SDA line is delayed as following clock time(PCLK) 00: 0 clocks 01: 5 clocks 10: 10 clocks 11: 15 clocks	00

21

IIS-BUS INTERFACE

OVERVIEW

Currently, many digital audio systems are attracting the consumers on the market, in the form of compact discs, digital audio tapes, digital sound processors, and digital TV sound. The S3C2440A Inter-IC Sound (IIS) bus interface can be used to implement a CODEC interface to an external 8/16-bit stereo audio CODEC IC for mini-disc and portable applications. The IIS bus interface supports both IIS bus data format and MSB-justified data format. The interface provides DMA transfer mode for FIFO access instead of an interrupt. It can transmit and receive data simultaneously as well as transmit or receive data alternatively at a time.

BLOCK DIAGRAM

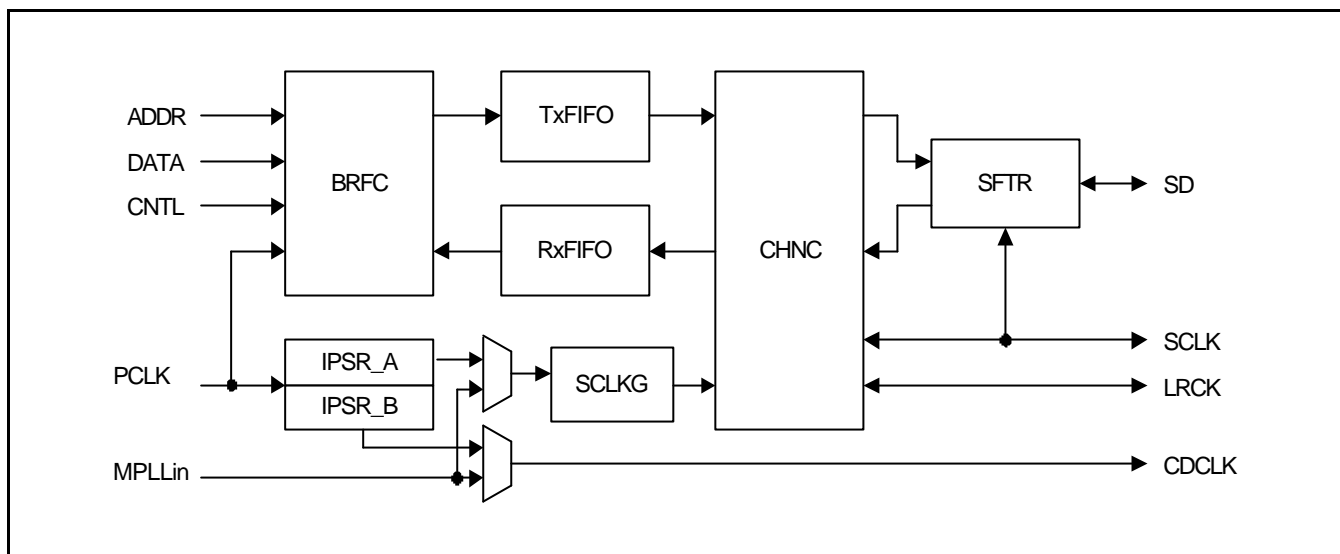

Figure 21-1. IIS-Bus Block Diagram

FUNCTIONAL DESCRIPTIONS

Bus interface, register bank, and state machine (BRFC): Bus interface logic and FIFO access are controlled by the state machine.

5-bit dual prescaler (IPSR): One prescaler is used as the master clock generator of the IIS bus interface and the other is used as the external CODEC clock generator.

64-byte FIFOs (Tx FIFO and Rx FIFO): In transmit data transfer, data are written to Tx FIFO, and, in the receive data transfer, data are read from Rx FIFO.

Master IISCLK generator (SCLKG): In master mode, serial bit clock is generated from the master clock.

Channel generator and state machine (CHNC): IISCLK and IISLRCK are generated and controlled by the channel state machine.

16-bit shift register (SFTR): Parallel data is shifted to serial data output in the transmit mode, and serial data input is shifted to parallel data in the receive mode.

TRANSMIT OR RECEIVE ONLY MODE

Normal Transfer

IIS control register has FIFO ready flag bits for transmit and receive FIFOs. When FIFO is ready to transmit data, the FIFO ready flag is set to '1' if transmit FIFO is not empty. If transmit FIFO is empty, FIFO ready flag is set to '0'. While receiving FIFO is not full, the FIFO ready flag for receive FIFO is set to '1'; it indicates that FIFO is ready to receive data. If receive FIFO is full, FIFO ready flag is set to '0'. These flags can determine the time that CPU is to write or read FIFOs. Serial data can be transmitted or received while the CPU is accessing transmit and receive FIFOs in this way.

DMA TRANSFER

In this mode, transmit or receive FIFO is accessible by the DMA controller. DMA service request in transmit or receive mode is made by the FIFO ready flag automatically.

TRANSMIT AND RECEIVE MODE

In this mode, IIS bus interface can transmit and receive data simultaneously.

AUDIO SERIAL INTERFACE FORMAT

IIS-BUS FORMAT

The IIS bus has four lines including serial data input (IISDI), serial data output (IISDO), left/right channel select (IISLRCK), and serial bit clock (IISCLK); the device generating IISLRCK and IISCLK is the master.

Serial data is transmitted in 2's complement with the MSB first. The MSB is transmitted first because the transmitter and receiver may have different word lengths. The transmitter does not have to know how many bits the receiver can handle, nor does the receiver need to know how many bits are being transmitted.

When the system word length is greater than the transmitter word length, the word is truncated (least significant data bits are set to '0') for data transmission. If the receiver gets more bits than its word length, the bits after the LSB are ignored. On the other hand, if the receiver gets fewer bits than its word length, the missing bits are set to zero internally. And therefore, the MSB has a fixed position, whereas the position of the LSB depends on the word length. The transmitter sends the MSB of the next word at one clock period whenever the IISLRCK is changed.

Serial data sent by the transmitter may be synchronized with either the trailing (HIGH to LOW) or the leading (LOW to HIGH) edge of the clock signal. However, the serial data must be latched into the receiver on the leading edge of the serial clock signal, and so there are some restrictions when transmitting data that is synchronized with the leading edge.

The LR channel select line indicates the channel being transmitted. IISLRCK may be changed either on a trailing or leading edge of the serial clock, but it does not need to be symmetrical. In the slave, this signal is latched on the leading edge of the clock signal. The IISLRCK line changes one clock period before the MSB is transmitted. This allows the slave transmitter to derive synchronous timing of the serial data that will be set up for transmission. Furthermore, it enables the receiver to store the previous word and clear the input for the next word.

MSB (LEFT) JUSTIFIED

MSB / left justified bus format is the same as IIS bus format architecturally. Only, different from the IIS bus format, the MSB justified format realizes that the transmitter always sends the MSB of the next word whenever the IISLRCK is changed.

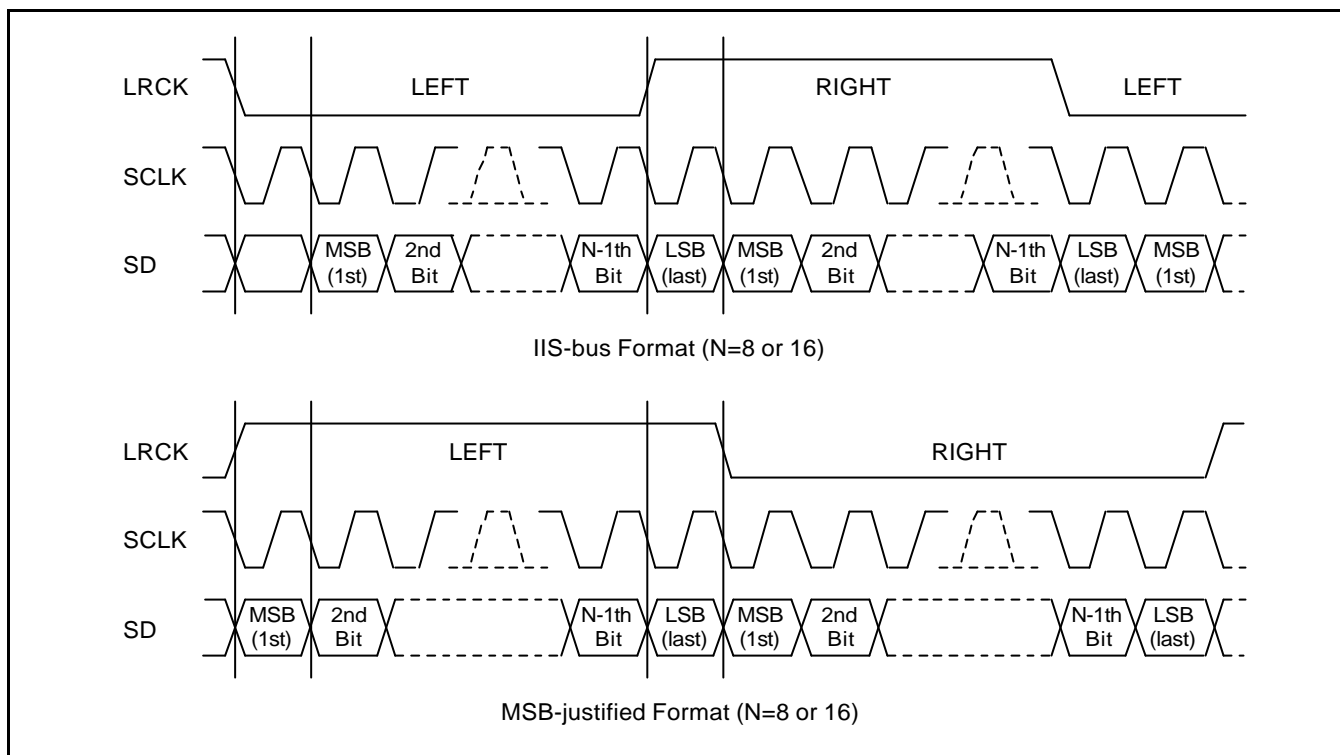

Figure 21-2. IIS-Bus and MSB (Left)-justified Data Interface Formats

SAMPLING FREQUENCY AND MASTER CLOCK

Master clock frequency (PCLK or MPLLIn) can be selected by sampling frequency as shown in Table 21-1. Because Master clock is made by IIS prescaler, the prescaler value and Master clock type (256 or 384fs) should be determined properly. Serial bit clock frequency type (16/32/48fs) can be selected by the serial bit per channel and Master clock as shown in Table 21-2.

Table 21-1. CODEC clock (CODECLK = 256 or 384fs)

IISLRCK (fs)	8.000 kHz	11.025 kHz	16.000 kHz	22.050 kHz	32.000 kHz	44.100 kHz	48.000 kHz	64.000 kHz	88.200 kHz	96.000 kHz
CODECLK (MHz)	256fs									
	2.0480	2.8224	4.0960	5.6448	8.1920	11.2896	12.2880	16.3840	22.5792	24.5760
CODECLK (MHz)	384fs									
	3.0720	4.2336	6.1440	8.4672	12.2880	16.9344	18.4320	24.5760	33.8688	36.8640

Table 21-2. Usable Serial Bit Clock Frequency (IISCLK = 16 or 32 or 48fs)

Serial bit per channel	8-bit		16-bit	
Serial clock frequency (IISCLK)				
@CODECLK = 256fs	16fs, 32fs		32fs	
@CODECLK = 384fs	16fs, 32fs, 48fs		32fs, 48fs	

IIS-BUS INTERFACE SPECIAL REGISTERS

IIS CONTROL (IISCON) REGISTER

Register	Address	R/W	Description	Reset Value
IISCON	0x55000000 (Li/HW, Li/W, Bi/W) 0x55000002 (Bi/HW)	R/W	IIS control register	0x100

IISCON	Bit	Description	Initial State
Left/Right channel index (Read only)	[8]	0 = Left 1 = Right	1
Transmit FIFO ready flag (Read only)	[7]	0 = Empty 1 = Not empty	0
Receive FIFO ready flag (Read only)	[6]	0 = Full 1 = Not full	0
Transmit DMA service request	[5]	0 = Disable 1 = Enable	0
Receive DMA service request	[4]	0 = Disable 1 = Enable	0
Transmit channel idle command	[3]	In Idle state the IISLRCK is inactive (Pause Tx). 0 = Not idle 1 = Idle	0
Receive channel idle command	[2]	In Idle state the IISLRCK is inactive (Pause Rx). 0 = Not idle 1 = Idle	0
IIS prescaler	[1]	0 = Disable 1 = Enable	0
IIS interface	[0]	0 = Disable (stop) 1 = Enable (start)	0

NOTES:

1. The IISCON register is accessible for each byte, halfword and word unit using STRB/STRH/STR and LDRB/LDRH/LDR instructions or char/short int/int type pointer in Little/Big endian mode.
2. (Li/HW/W) : Little/HalfWord/Word
(Bi/HW/W) : Big/HalfWord/Word

IIS MODE REGISTER (IISMOD) REGISTER

Register	Address	R/W	Description	Reset Value
IISMOD	0x55000004 (Li/W, Li/HW, Bi/W) 0x55000006 (Bi/HW)	R/W	IIS mode register	0x0

IISMOD	Bit	Description	Initial State
Master clock select	[9]	Master clock select 0 = PCLK 1 = MPLLin	0
Master/slave mode select	[8]	0 = Master mode (IISLRCK and IISCLK are output mode). 1 = Slave mode (IISLRCK and IISCLK are input mode).	0
Transmit/receive mode select	[7:6]	00 = No transfer 01 = Receive mode 10 = Transmit mode 11 = Transmit and receive mode	00
Active level of left/right channel	[5]	0 = Low for left channel (High for right channel) 1 = High for left channel (Low for right channel)	0
Serial interface format	[4]	0 = IIS compatible format 1 = MSB (Left)-justified format	0
Serial data bit per channel	[3]	0 = 8-bit 1 = 16-bit	0
Master clock frequency select	[2]	0 = 256fs 1 = 384fs (fs: sampling frequency)	0
Serial bit clock frequency select	[1:0]	00 = 16fs 01 = 32fs 10 = 48fs 11 = N/A	00

NOTES:

- The IISMOD register is accessible for each halfword and wordunit using STRH/STR and LDRH/LDR instructions or short int/int type pointer in Little/Big endian mode.
- (Li/HW/W) : Little/HalfWord/Word.
(Bi/HW/W) : Big/HalfWord/Word.

IIS PRESCALER (IISPSR) REGISTER

Register	Address	R/W	Description	Reset Value
IISPSR	0x55000008 (Li/HW, Li/W, Bi/W) 0x5500000A (Bi/HW)	R/W	IIS prescaler register	0x0

IISPSR	Bit	Description	Initial State
Prescaler control A	[9:5]	Data value: 0 ~ 31 Note: Prescaler A makes the master clock that is used the internal block and division factor is N+1.	00000
Prescaler control B	[4:0]	Data value: 0 ~ 31 Note: Prescaler B makes the master clock that is used the external block and division factor is N+1.	00000

NOTES:

1. The IISPSR register is accessible for each byte, halfword and word unit using STRB/STRH/STR and LDRB/LDRH/LDR instructions or char/short int/int type pointer in Little/Big endian mode.
2. (Li/HW/W): Little/HalfWord/Word.
(Bi/HW/W): Big/HalfWord/Word.

IIS FIFO CONTROL (IISFCN) REGISTER

Register	Address	R/W	Description	Reset Value
IISFCN	0x5500000C (Li/HW, Li/W, Bi/W) 0x5500000E (Bi/HW)	R/W	IIS FIFO interface register	0x0

IISFCN	Bit	Description	Initial State
Transmit FIFO access mode select	[15]	0 = Normal 1 = DMA	0
Receive FIFO access mode select	[14]	0 = Normal 1 = DMA	0
Transmit FIFO	[13]	0 = Disable 1 = Enable	0
Receive FIFO	[12]	0 = Disable 1 = Enable	0
Transmit FIFO data count (Read only)	[11:6]	Data count value = 0 ~ 32	000000
Receive FIFO data count (Read only)	[5:0]	Data count value = 0 ~ 32	000000

NOTES:

- The IISFCN register is accessible for each halfword and word unit using STRH/STR and LDRH/LDR instructions or short int/int type pointer in Little/Big endian mode.
- (Li/HW/W): Little/HalfWord/Word.
(Bi/HW/W): Big/HalfWord/Word.

IIS FIFO (IISFIFO) REGISTER

IIS bus interface contains two 64-byte FIFO for the transmit and receive mode. Each FIFO has 16-width and 32-depth form, which allows the FIFO to handles data for each halfword unit regardless of valid data size. Transmit and receive FIFO access is performed through FIFO entry; the address of FENTRY is 0x55000010.

Register	Address	R/W	Description	Reset Value
IISFIFO	0x55000010(Li/HW) 0x55000012(Bi/HW)	R/W	IIS FIFO register	0x0

IISFIF	Bit	Description	Initial State
FENTRY	[15:0]	Transmit/Receive data for IIS	0x0

NOTES:

- The IISFIFO register is accessible for each halfword and word unit using STRH and LDRH instructions or short int type pointer in Little/Big endian mode.
- (Li/HW): Little/HalfWord.
(Bi/HW): Big/HalfWord.

22

SPI

OVERVIEW

The S3C2440A Serial Peripheral Interface (SPI) can interface with the serial data transfer. The S3C2440A includes two SPI, each of which has two 8-bit shift registers for transmission and receiving, respectively. During an SPI transfer, data is simultaneously transmitted (shifted out serially) and received (shifted in serially). 8-bit serial data at a frequency is determined by its corresponding control register settings. If you only want to transmit, receive data can be kept dummy. Otherwise, if you only want to receive, you should transmit dummy '1' data.

There are 4 I/O pin signals associated with SPI transfers: SCK (SPICLK0,1), MISO (SPIMISO0,1) data line, MOSI (SPIMOSI0,1) data line and active low /SS (nSS0,1) pin (input).

FEATURES

- Support 2-ch SPI
- SPI Protocol (ver. 2.11) compatible
- 8-bit Shift Register for transmit
- 8-bit Shift Register for receive
- 8-bit Prescaler logic
- Polling, Interrupt and DMA transfer mode

BLOCK DIAGRAM

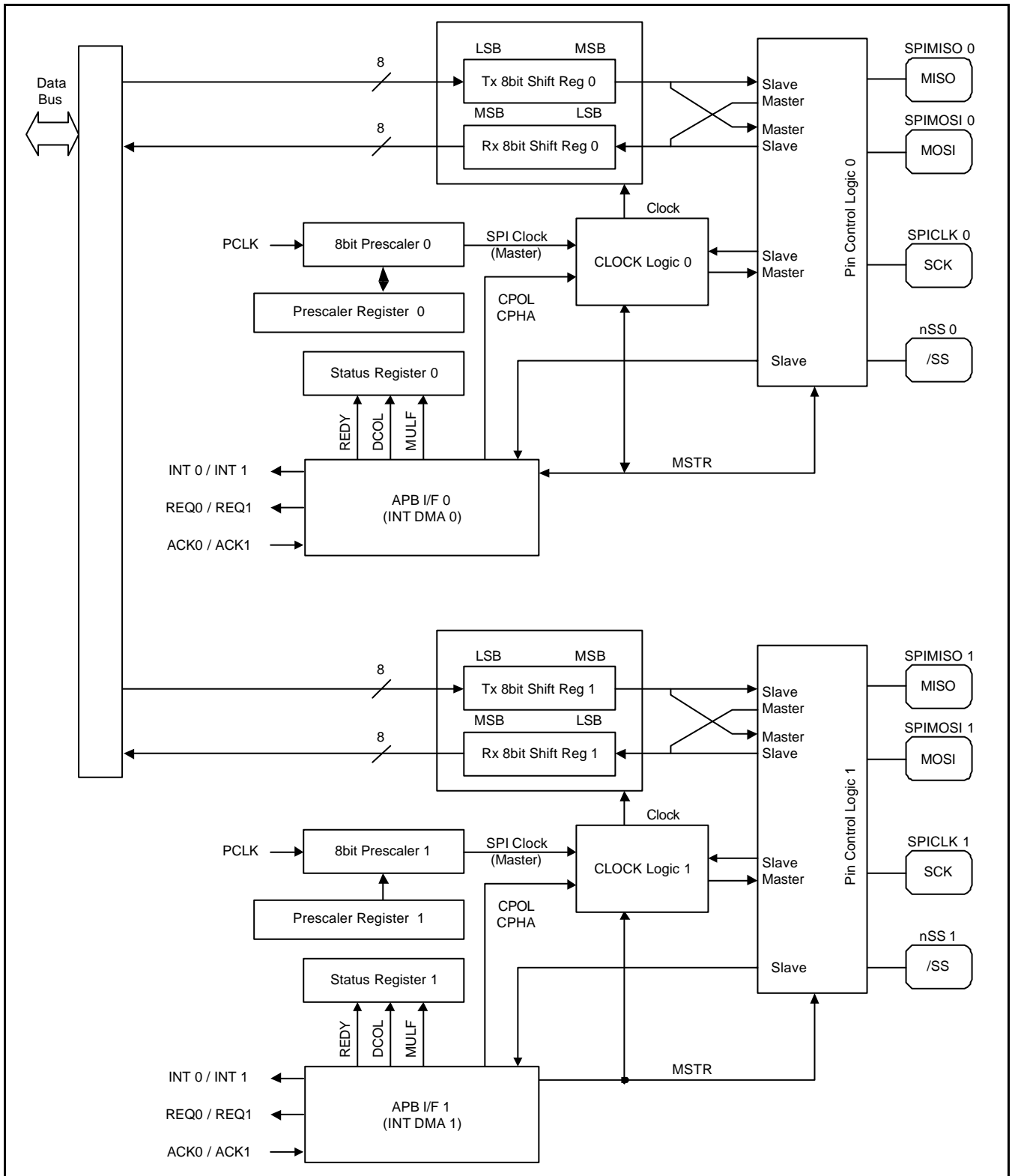

Figure 22-1. SPI Block Diagram

SPI OPERATION

Using the SPI interface, S3C2440A can send/receive 8-bit data simultaneously with an external device. A serial clock line is synchronized with the two data lines for shifting and sampling of the information. When the SPI is the master, transmission frequency can be controlled by setting the appropriate bit in SPPREn register. You can modify its frequency to adjust the baud rate data register value. When the SPI is a slave, other master supplies the clock. When the programmer writes byte data to SPTDATn register, SPI transmit/receive operation will start simultaneously. In some cases, nSS should be activated before writing byte data to SPTDATn.

PROGRAMMING PROCEDURE

When a byte data is written into the SPTDATn register, SPI starts to transmit if ENSCK and MSTR of SPCONn register are set. You can use a typical programming procedure to operate an SPI card.

To program the SPI modules, follow these basic steps:

1. Set Baud Rate Prescaler Register (SPPREn).
2. Set SPCONn to configure properly the SPI module.
3. Write data 0xFF to SPTDATn 10 times in order to initialize MMC or SD card.
4. Set a GPIO pin, which acts as nSS, low to activate the MMC or SD card.
5. Tx data ; Check the status of Transfer Ready flag (REDY=1), and then write data to SPTDATn.
6. Rx data(1): SPCONn's TAGD bit disable = normal mode
7. ; write 0xFF to SPTDATn, then confirm REDY to set, and then read data from Read Buffer.
8. Rx data(2): SPCONn's TAGD bit enable = Tx Auto Garbage Data mode
9. ; confirm REDY to set, and then read data from Read Buffer (then automatically start to transfer).
10. Set a GPIO pin, which acts as nSS, high to deactivate the MMC or SD card.

SPI TRANSFER FORMAT

The S3C2440A supports 4 different formats to transfer data. Figure 22-2 shows the four waveforms for SPICLK.

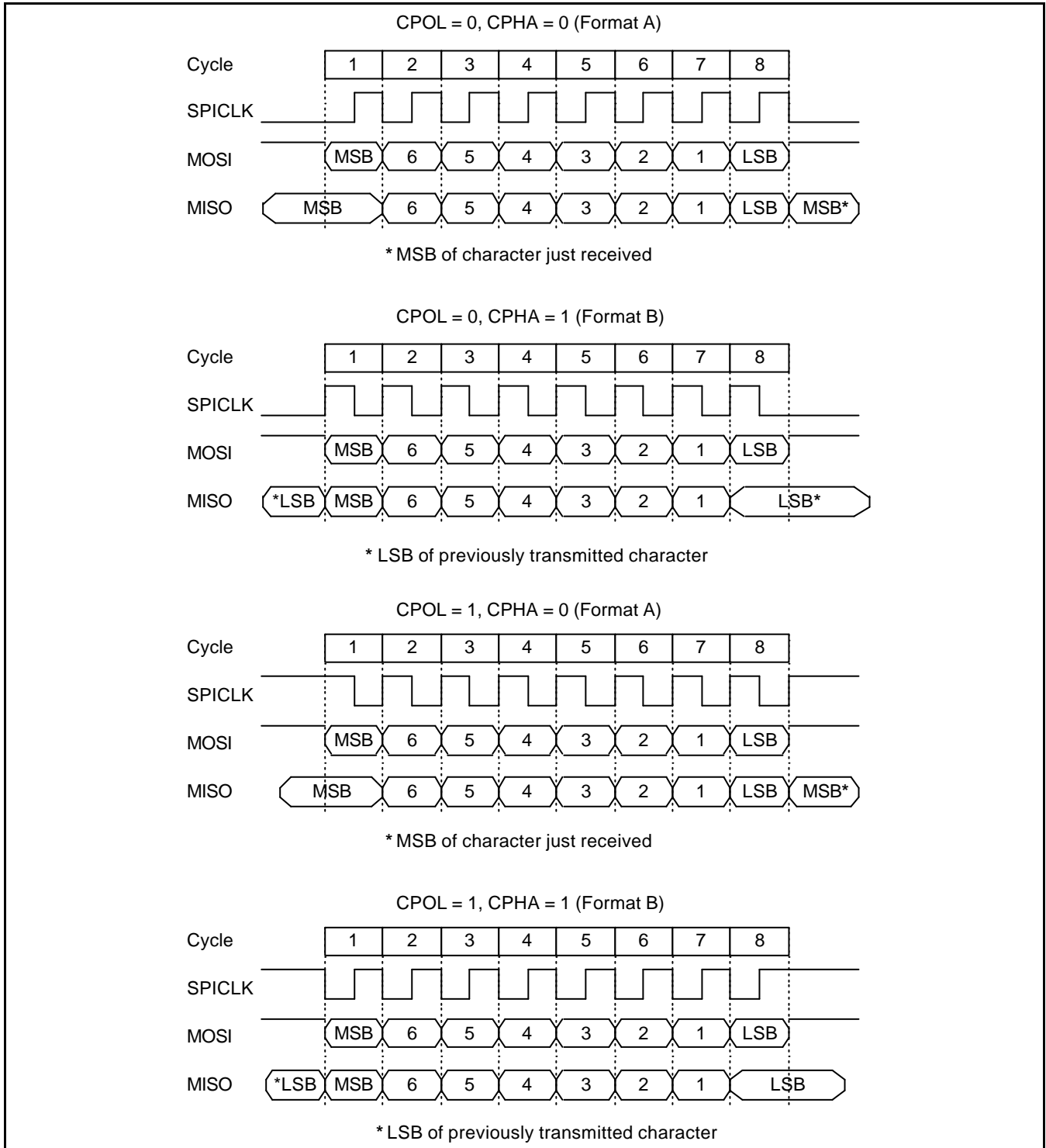

Figure 22-2. SPI Transfer Format

TRANSMITTING PROCEDURE FOR DMA

1. SPI is configured as DMA mode.
2. DMA is configured properly.
3. SPI requests DMA service.
4. DMA transmits 1byte data to the SPI.
5. SPI transmits the data to card.
6. Return to Step 3 until DMA count becomes 0.
6. SPI is configured as interrupt or polling mode with SMOD bits.

RECEIVING PROCEDURE FOR DMA

1. SPI is configured as DMA start with SMOD bits and TAGD bit set.
2. DMA is configured properly.
3. SPI receives 1byte data from card.
4. SPI requests DMA service.
5. DMA receives the data from the SPI.
6. Write data 0xFF automatically to SPTDATn.
7. Return to Step 4 until DMA count becomes 0.
8. SPI is configured as polling mode with SMOD bits and clear TAGD bit.
9. If SPSTAn's READY flag is set, then read the last byte data.

NOTE

Total received data = DMA TC values + the last data in polling mode (Step 9).
The first DMA received data is dummy and the user can neglect it.

SPI SPECIAL REGISTERS

SPI CONTROL REGISTER

Register	Address	R/W	Description	Reset Value
SPCON0	0x59000000	R/W	SPI channel 0 control register	0x00
SPCON1	0x59000020	R/W	SPI channel 1 control register	0x00

SPCONn	Bit	Description	Initial State
SPI Mode Select (SMOD)	[6:5]	Determine how SPTDAT is read/written 00 = polling mode 01 = interrupt mode 10 = DMA mode 11 = reserved	00
SCK Enable (ENSCK)	[4]	Determine whether you want SCK enabled or not (master only). 0 = disable 1 = enable	0
Master/Slave Select (MSTR)	[3]	Determine the desired mode (master or slave). 0 = slave 1 = master Note: In slave mode, there should be set up time for master to initiate Tx/Rx.	0
Clock Polarity Select (CPOL)	[2]	Determine an active high or active low clock. 0 = active high 1 = active low	0
Clock Phase Select (CPHA)	[1]	Select one of the two fundamentally different transfer format 0 = format A 1 = format B	0
Tx Auto Garbage Data mode enable (TAGD)	[0]	Decide whether the receiving data is required or not. 0 = normal mode 1 = Tx auto garbage data mode Note: In normal mode, if you only want to receive data, you should transmit dummy 0xFF data.	0

SPI BAUD RATE PRESCALER REGISTER

Register	Address	R/W	Description	Reset Value
SPPRE0	0x5900000C	R/W	SPI channel 0 baud rate prescaler register	0x00
SPPRE1	0x5900002C	R/W	SPI channel 1 baud rate prescaler register	0x00

SPPREn	Bit	Description	Initial State
Prescaler Value	[7:0]	Determine SPI clock rate. Baud rate = PCLK / 2 / (Prescaler value + 1)	0x00

NOTE: Baud rate should be less than 25 MHz.

SPI TX DATA REGISTER

Register	Address	R/W	Description	Reset Value
SPTDAT0	0x59000010	R/W	SPI channel 0 Tx data register	0x00
SPTDAT1	0x59000030	R/W	SPI channel 1 Tx data register	0x00

SPTDATn	Bit	Description	Initial State
Tx Data Register	[7:0]	This field contains the data to be transmitted over the SPI channel.	0x00

SPI RX DATA REGISTER

Register	Address	R/W	Description	Reset Value
SPRDAT0	0x59000014	R	SPI channel 0 Rx data register	0xFF
SPRDAT1	0x59000034	R	SPI channel 1 Rx data register	0xFF

SPRDATn	Bit	Description	Initial State
Rx Data Register	[7:0]	This field contains the data to be received over the SPI channel.	0xFF

NOTES

23

CAMERA INTERFACE

OVERVIEW

This chapter will explain the specification and defines the camera interface. **CAMIF (CAMera InterFace)** within the S3C2440A consists of 7 parts – **pattern mux, capturing unit, preview scaler, codec scaler, preview DMA, codec DMA, and SFR**. The CAMIF supports ITU-R BT.601/656 YCbCr 8-bit standard. Maximum input size is 4096x4096 pixels (2048x2048 pixels for scaling) and two scalers exist. Preview scaler is dedicated to generate smaller size image like **PIP** (Picture In Picture) and codec scaler is dedicated to generate codec useful image like plane type YCbCr 4:2:0 or 4:2:2. Two master DMAs can do mirror and rotate the captured image for mobile environments. These features are very useful in folder type cellular phones and the test pattern generated can be useful in calibration of input sync signals as CAMHREF, CAMVSYNC. Also, video sync signals and pixel clock polarity can be inverted in the CAMIF side by using register setting.

FEATURES

- ITU-R BT. 601/656 8-bit mode external interface support
- DZI (Digital Zoom In) capability
- Programmable polarity of video sync signals
- Max. 4096 x 4096 pixel input support without scaling (2048 x 2048 pixel input support with scaling)
- Max. 4096 x 4096 pixel output support for CODEC path
- Max. 640 x 480 pixel output support for PREVIEW path
- Image mirror and rotation (X-axis mirror, Y-axis mirror, and 180° rotation)
- PIP and codec input image generation (RGB 16/24-bit format and YCbCr 4:2:0/4:2:2 format)

SIGNAL DESCRIPTION

Table 23-1. Camera Interface Signal Description

Name	I/O	Active	Description
CAMPCLK	I	–	Pixel clock, driven by the camera processor
CAMVSYNC	I	H/L	Frame sync, driven by the camera processor
CAMHREF	I	H/L	Horizontal sync, driven by the camera processor
CAMDATA[7:0]	I	–	Pixel data driven by the camera processor
CAMCLKOUT	O	–	Master clock to the camera processor
CAMRESET	O	H/L	Software reset or power down to the camera processor

NOTE: I/O direction is on the AP side. I: input, O: output

BLOCK DIAGRAM

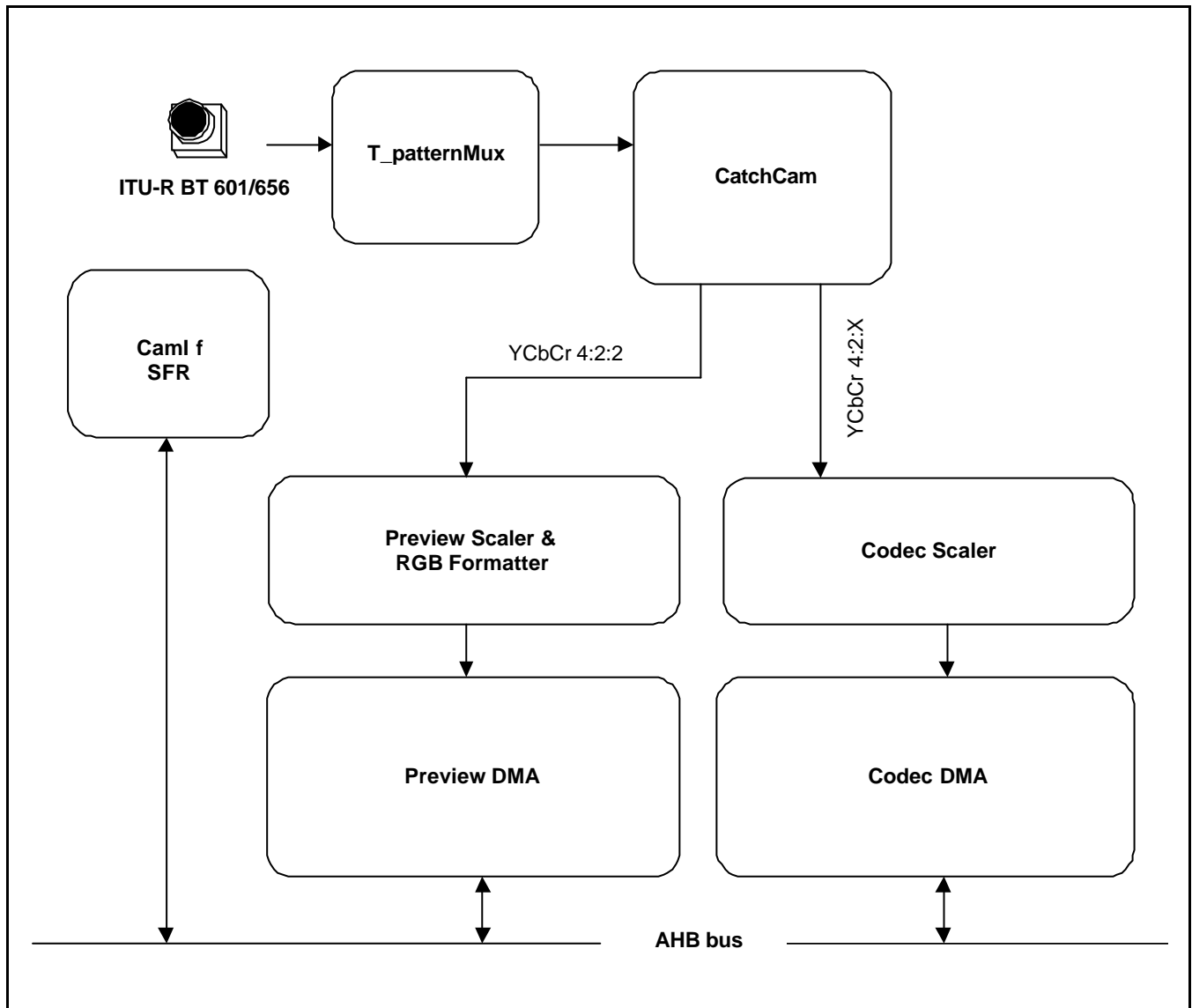

Figure 23-1. CAMIF Overview

TIMING DIAGRAM

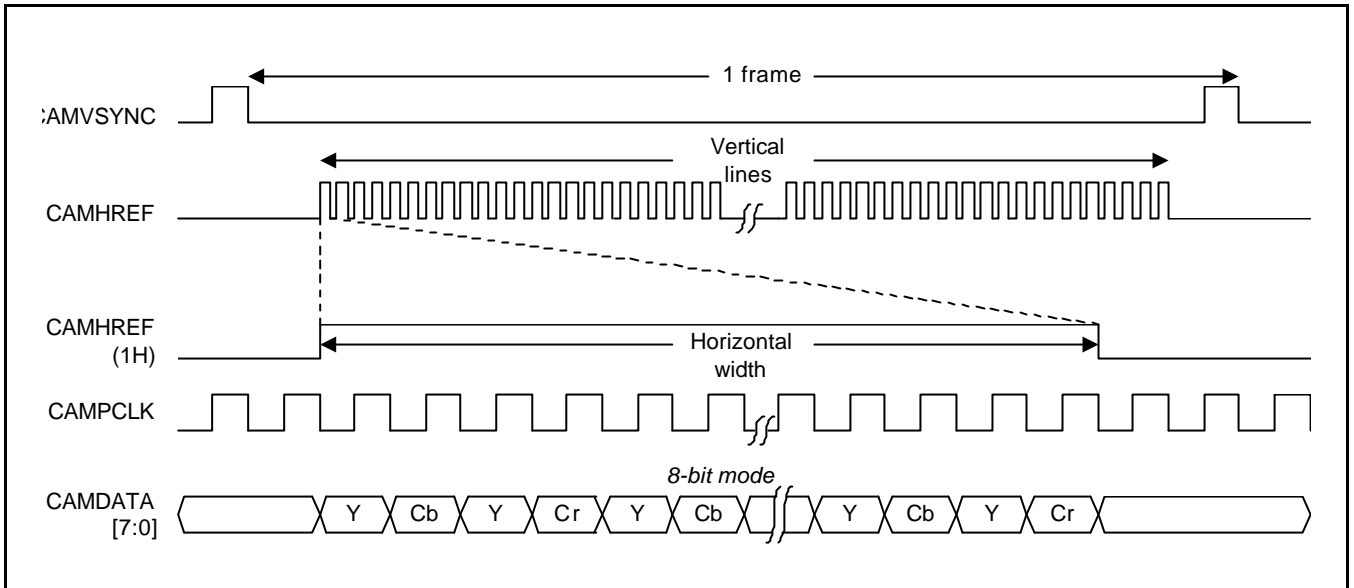

Figure 23-2. ITU-R BT 601 Input Timing Diagram

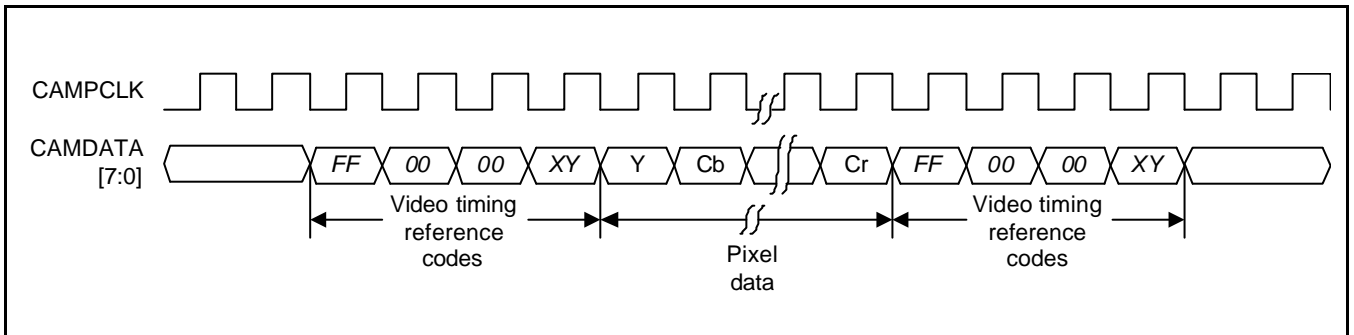

Figure 23-3. ITU-R BT 656 Input Timing Diagram

There are two timing reference signals in ITU-R BT 656 format, one is at the beginning of each video data block (start of active video, SAV) and other is at the end of each video data block (end of active video, EAV) as shown in Figure 23-3 and Table 23-2.

Table 23-2. Video Timing Reference Codes of ITU-656 Format

Data Bit Number	First Word	Second Word	Third Word	Fourth Word
9 (MSB)	1	0	0	1
8	1	0	0	F
7	1	0	0	V
6	1	0	0	H
5	1	0	0	P3
4	1	0	0	P2
3	1	0	0	P1
2	1	0	0	P0
1 (NOTE)	1	0	0	0
0	1	0	0	0

For compatibility with existing 8-bit interfaces, the values of bits D1 and D0 are not defined.

F = 0 (during field 1), 1 (during field 2)

V = 0 (elsewhere), 1 (during field blanking)

H = 0 (in SAV: Start of Active Video), 1 (in EAV: End of Active Video)

P0, P1, P2, P3 = protection bit

Camera interface logic can catch the video sync bits like H (SAV, EAV) and V (Frame Sync) after reserved data as "FF-00-00".

NOTE: All external camera interface IOs are recommended to be Schmitt-trigger type IO for noise reduction.

CAMERA INTERFACE OPERATION

TWO DMA PATHS

CAMIF has 2 DMA paths. **P-path (Preview path)** and **C-path (Codec path)** are separated from each other on the AHB bus. In view of the system bus, both the paths are independent. The P-path stores the RGB image data into memory for PIP. The C-path stores the YCbCr 4:2:0 or 4:2:2 image data into memory for Codec as MPEG-4, H.263, etc. These two master paths support the variable applications like DSC (Digital Steel Camera), MPEG-4 video conference, video recording, etc. *For example*, P-path image can be used as preview image, and C-path image can be used as JPEG image in DSC application. Register setting can separately disable to P-path or C-path.

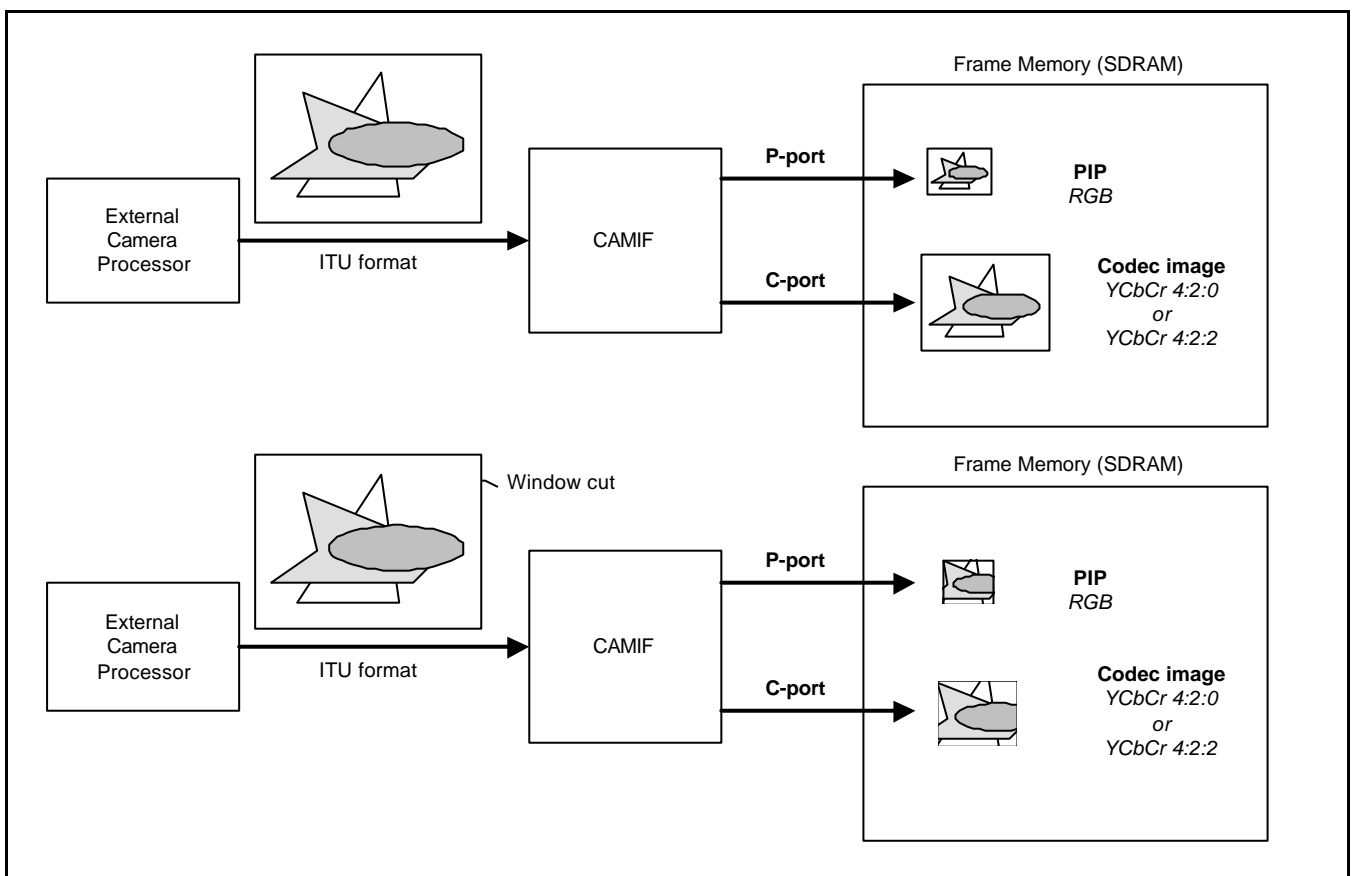

Figure 23-4. Two DMA Paths

CLOCK DOMAIN

CAMIF has two clock domains. One is the system bus clock, which is **HCLK**. The other is the pixel clock, which is **CAMPCLK**. **The system clock must be faster than pixel clock**. Figure 23-5 shows CAMCLKOUT must be divided from the fixed frequency like USB PLL clock. If external clock oscillator is used, CAMCLKOUT should be floated. Internal scaler clock is system clock. It is not necessary for two clock domains to synchronize each other. Other signals such as CAMPCLK should be similarly connected to the Schmitt-triggered level shifter.

FRAME MEMORY HIRERARCHY

Frame memories consist of four ping-pong memories for each of P and C paths as shown in the Figure 23-6. C-path ping-pong memories have three element memories – luminance Y, chrominance Cb, and chrominance Cr. If AHB-bus traffic is not enough for the DMA operation to complete during one horizontal line period, it may lead to malfunctioning

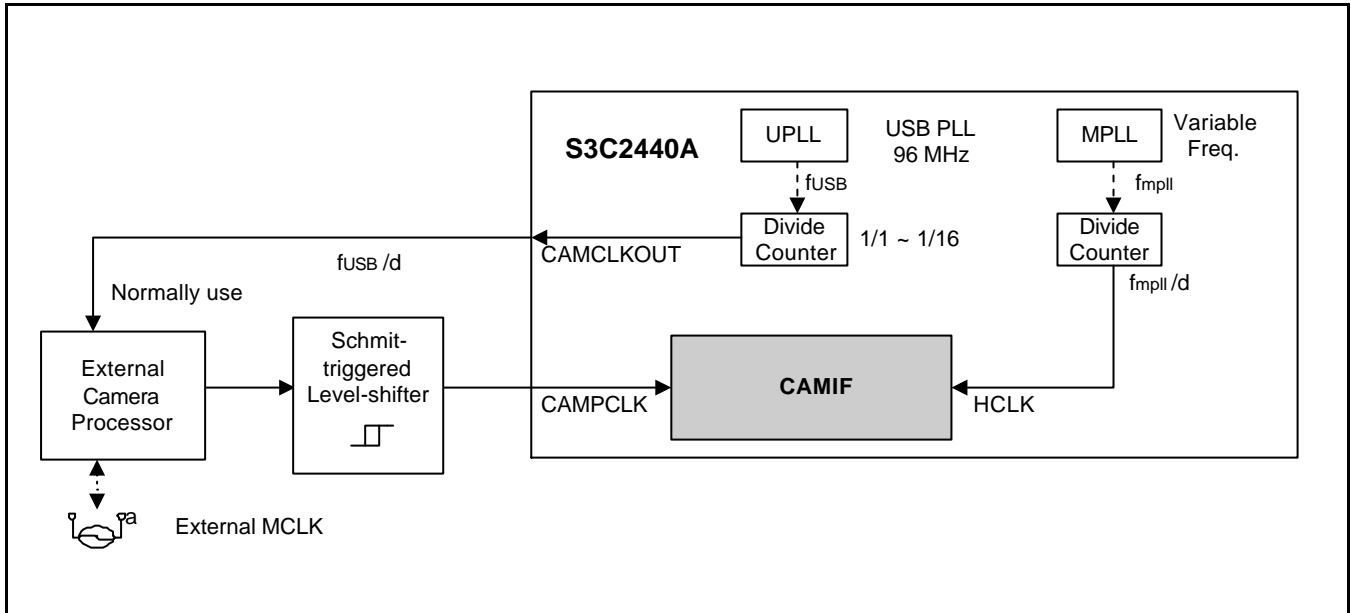

Figure 23-5. CAMIF Clock Generation

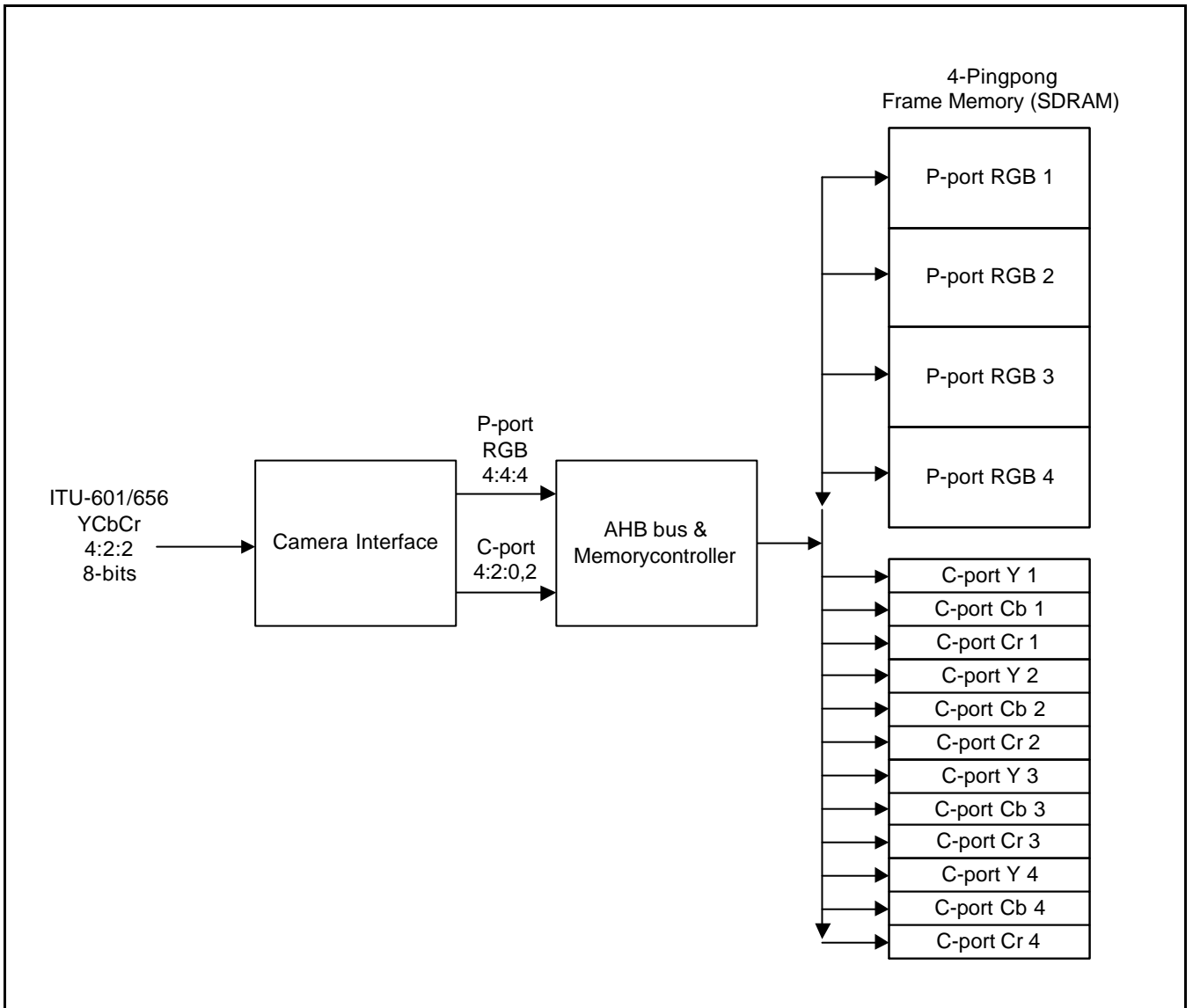

Figure 23-6. Ping-Pong Memory Hierarchy

MEMORY STORING METHOD

The little-endian method in codec path is used to store in the frame memory. The pixels are stored from LSB to MSB side. AHB bus carries 32-bit word data. So, CAMIF makes each of the Y-Cb-Cr words in little-endian style. For preview path, two different formats exist. One pixel (Color 1 pixel) is one word for RGB 24-bit format. Otherwise, two pixels are one word for RGB 16-bit format. Please refer the following figure.

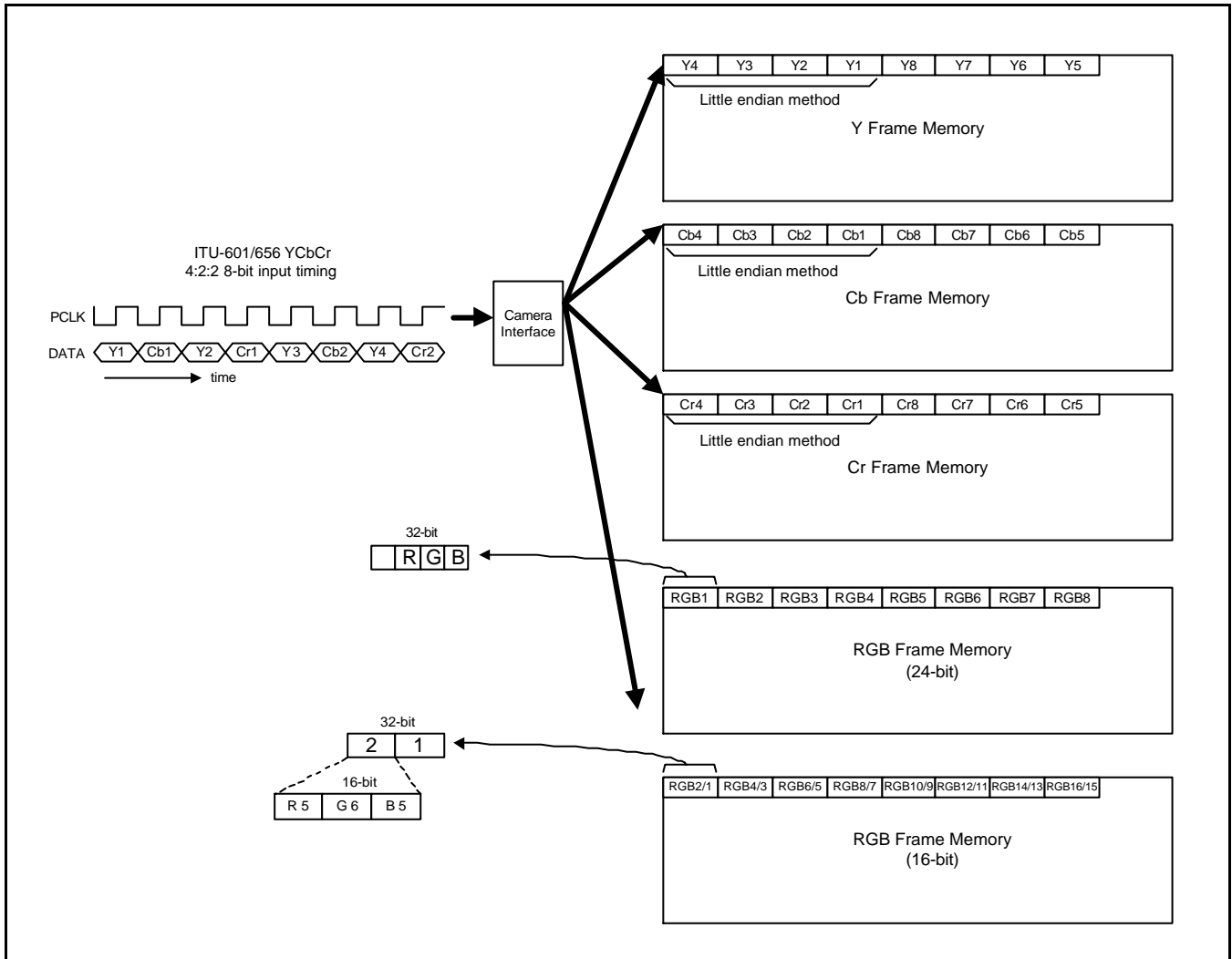

Figure 23-7. Memory Storing Style

TIMING DIAGRAM FOR REGISTER SETTING

The first register setting for frame capture command can occur anywhere in the frame period. But, it is recommended that you set it at the CAMVSYNC “L” state first and the CAMVSYNC information can be read from the status SFR (Please see next page). All command include *ImgCptEn*, is valid at CAMVSYNC falling edge. But be careful that except for first SFR setting, all command should be programmed in an **ISR (Interrupt Service Routine)**. Especially, capture operation should be disabled when related information for target size are changed.

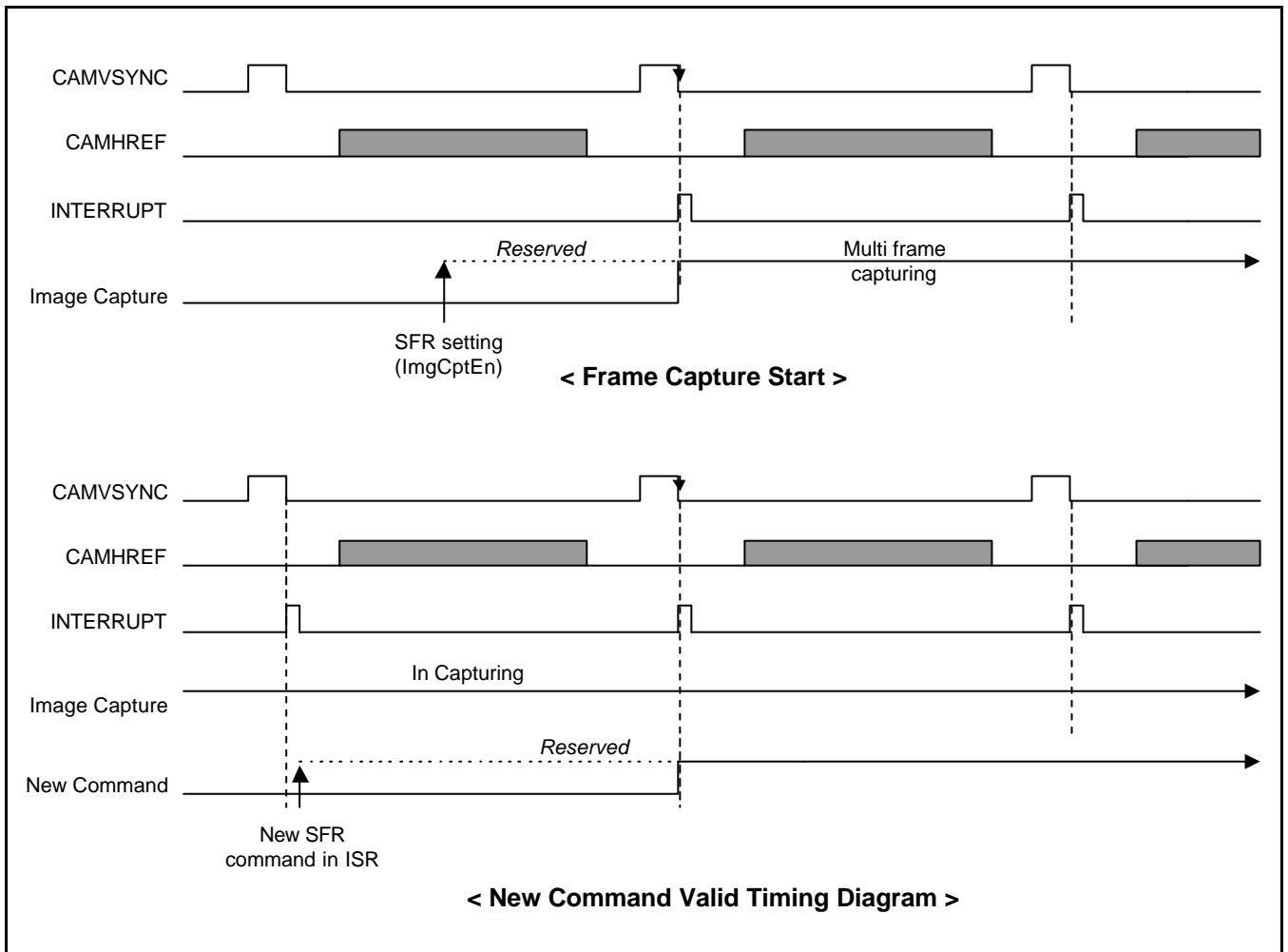

Figure 23-8. Timing Diagram for Register Setting

NOTE: FIFO overflow of codec path will be occurred if codec path is not operating when preview path is operated. If you want to use codec path under this case, you should stop preview path and reset CAMIF using *SwRst* bit of *CIGCTRL* register. Then clear overflow of codec path and set special function registers that you want.

TIMING DIAGRAM FOR LAST IRQ

IRQ except LastIRQ is generated before image capturing. Last IRQ which means capture-end can be set by following timing diagram. LastIRQEn is auto-cleared and, as mentioned, SFR setting in ISR is for next frame command. So, for adequate last IRQ, you should follow next sequence between LastIRQEn and ImgCptEn /ImgCptEn_CoSc /ImgCptEnPrSC. It is recommended that ImgCptEn /ImgCptEn_CoSc /ImgCptEnPrSC are set at same time and at last of SFR setting in ISR. FrameCnt which is read in ISR, means next frame count. On following diagram, last captured frame count is "1". That is, Frame 1 is the last-captured frame among frame 0~3. FrameCnt is increased by 1 at IRQ rising.

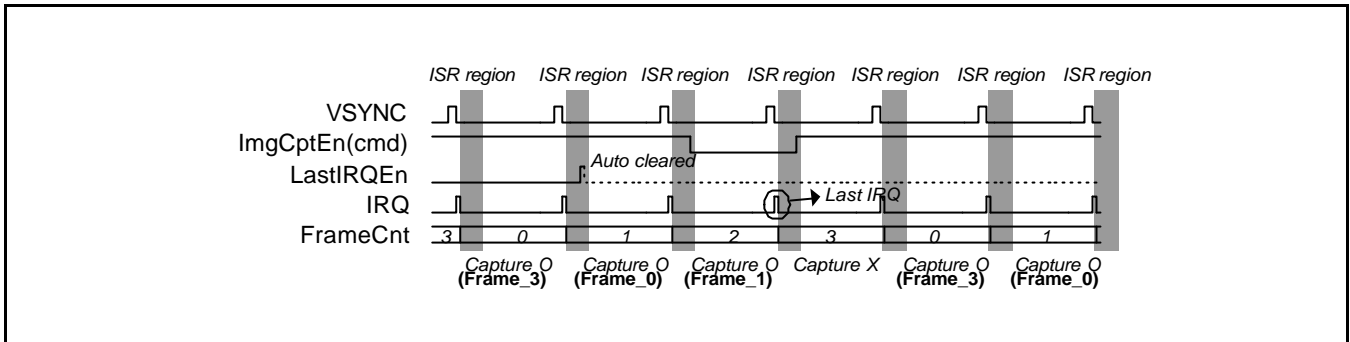

Figure 23-9. Timing diagram for last IRQ

CAMERA INTERFACE SPECIAL REGISTERS

SOURCE FORMAT REGISTER

Register	Address	R/W	Description	Reset Value
CISRCFMT	0x4F000000	RW	Input source format register	0

CISRCFMT	Bit	Description	Initial State
ITU601_656n	[31]	0 = ITU-R BT.656 YCbCr 8-bit mode enable 1 = ITU-R BT.601 YCbCr 8-bit mode enable	0
UVOffset	[30]	Cb,Cr Value Offset Control. 0 = +0 (normally used) - for YCbCr 1 = +128 - for YUV	0
Reserved	[29]	This bit is reserved and the value must be 0.	0
SourceHsize	[28:16]	Source Horizontal Pixel Number (must be multiple of 8)	0
Order422	[15:14]	Input YcbCr order inform for input 8-bit mode 00 = YCbYCr 01 = YCrYCb 10 = CbYCrY 11 = CrYCbY	0
SourceVsize	[12:0]	Source Vertical Pixel Number	0

NOTE: We recommend a following sequence for preventing FIFO overflow at first frame of capture operation in CODEC path

<ITU 601 Format>

1. CISRCFMT[31] <- '1'
2. S/W reset
3. Initialize the Camera I/F
4. Start Capturing

<ITU 656 Format>

1. CISRCFMT[31] <- '1'
2. S/W reset
3. Initialize the Camera I/F
4. CISRCFMT[31] <- '0' //for ITU 656 format
6. Start Capturing
7. Clear Overflow of codec on First ISR

WINDOW OPTION REGISTER

Register	Address	R/W	Description	Reset Value
CIWDOFST	0x4F000004	RW	Window offset register	0

CIWDOFST	Bit	Description	Initial State
WinOfsEn	[31]	0 = No offset 1 = Window offset enable	0
ClrOvCoFiY	[30]	0 = Normal 1 = Clear the overflow indication flag of input CODEC FIFO Y	0
WinHorOfst	[26:16]	Window Horizontal Offset (the number which is the horizontal pixels except WinHorOfst * 2, must be multiple of 8) * WinHorOfst >= (SourceHsize-640*PreHorRatio_Pr)/2	0
ClrOvCoFiCb	[15]	0 = Normal 1 = Clear the overflow indication flag of input CODEC FIFO Cb	0
ClrOvCoFiCr	[14]	0 = Normal 1 = Clear the overflow indication flag of input CODEC FIFO Cr	0
ClrOvPrFiCb	[13]	0 = Normal 1 = Clear the overflow indication flag of input PREVIEW FIFO Cb	0
ClrOvPrFiCr	[12]	0 = Normal 1 = Clear the overflow indication flag of input PREVIEW FIFO Cr	0
WinVerOfst	[10:0]	Window Vertical Offset	0

NOTE: We recommend you to clear all the overflow bits before starting the capture operation.

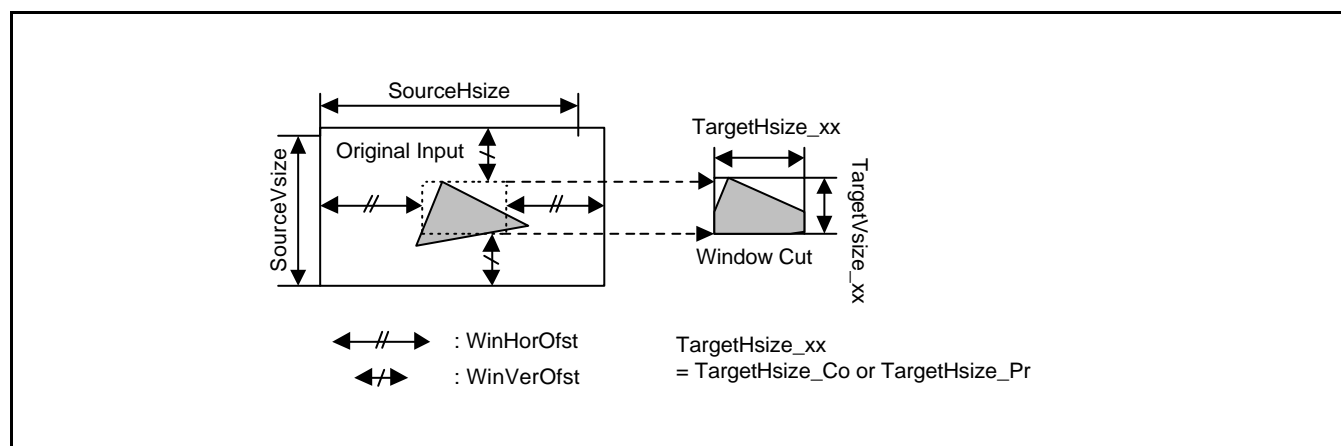

Figure 23-10. Window Offset Scheme

GLOBAL CONTROL REGISTER

Register	Address	R/W	Description	Reset Value
CIGCTRL	0x4F000008	RW	Global control register	0

CIGCTRL	Bit	Description	Initial State
SwRst	[31]	Camera interface software reset	0
CamRst	[30]	External camera processor reset or power down	0
Reserved	[29]	This bit is reserved and the value must be 1.	1
TestPattern	[28:27]	This register should be set only at ITU-T 601 8-bit mode. It is not allowed with ITU-T 656 mode. (max. 1280 X 1024) 00 = External camera processor input (normal) 01 = Color bar test pattern 10 = Horizontal increment test pattern 11 = Vertical increment test pattern	0
InvPolCAMCLK	[26]	0 = Normal 1 = Inverse the polarity of CAMCLK	0
InvPolCAMVSYNC	[25]	0 = Normal 1 = Inverse the polarity of CAMVSYNC	0
InvPolCAMHREF	[24]	0 = Normal 1 = Inverse the polarity of CAMHREF	0

Y1 START ADDRESS REGISTER

Register	Address	R/W	Description	Reset Value
CICOYSA1	0x4F000018	RW	Y 1 st frame start address for codec DMA	0

CICOYSA1	Bit	Description	Initial State
CICOYSA1	[31:0]	Y 1 st frame start address for codec DMA	0

NOTE: Address of buffers must be multiple of 1024.

Y2 START ADDRESS REGISTER

Register	Address	R/W	Description	Reset Value
CICOYSA2	0x4F00001C	RW	Y 2 nd frame start address for codec DMA	0

CICOYSA2	Bit	Description	Initial State
CICOYSA2	[31:0]	Y 2 nd frame start address for codec DMA	0

Y3 START ADDRESS REGISTER

Register	Address	R/W	Description	Reset Value
CICOYSA3	0x4F000020	RW	Y 3 rd frame start address for codec DMA	0

CICOYSA3	Bit	Description	Initial State
CICOYSA3	[31:0]	Y 3 rd frame start address for codec DMA	0

Y4 START ADDRESS REGISTER

Register	Address	R/W	Description	Reset Value
CICOYSA4	0x4F000024	RW	Y 4 th frame start address for codec DMA	0

CICOYSA4	Bit	Description	Initial State
CICOYSA4	[31:0]	Y 4 th frame start address for codec DMA	0

CB1 START ADDRESS REGISTER

Register	Address	R/W	Description	Reset Value
CICOCBSA1	0x4F000028	RW	Cb 1 st frame start address for codec DMA	0

CICOCBSA1	Bit	Description	Initial State
CICOCBSA1	[31:0]	Cb 1 st frame start address for codec DMA	0

CB2 START ADDRESS REGISTER

Register	Address	R/W	Description	Reset Value
CICOCBSA2	0x4F00002C	RW	Cb 2 nd frame start address for codec DMA	0

CICOCBSA2	Bit	Description	Initial State
CICOCBSA2	[31:0]	Cb 2 nd frame start address for codec DMA	0

CB3 START ADDRESS REGISTER

Register	Address	R/W	Description	Reset Value
CICOCBSA3	0x4F000030	RW	Cb 3 rd frame start address for codec DMA	0

CICOCBSA3	Bit	Description	Initial State
CICOCBSA3	[31:0]	Cb 3 rd frame start address for codec DMA	0

CB4 START ADDRESS REGISTER

Register	Address	R/W	Description	Reset Value
CICOCBSA4	0x4F000034	RW	Cb 4 th frame start address for codec DMA	0

CICOCBSA4	Bit	Description	Initial State
CICOCBSA4	[31:0]	Cb 4 th frame start address for codec DMA	0

CR1 START ADDRESS REGISTER

Register	Address	R/W	Description	Reset Value
CICOCRSA1	0x4F000038	RW	Cr 1 st frame start address for codec DMA	0

CICOCRSA1	Bit	Description	Initial State
CICOCRSA1	[31:0]	Cr 1 st frame start address for codec DMA	0

CR2 START ADDRESS REGISTER

Register	Address	R/W	Description	Reset Value
CICOCRSA2	0x4F00003C	RW	Cr 2 nd frame start address for codec DMA	0

CICOCRSA2	Bit	Description	Initial State
CICOCRSA2	[31:0]	Cr 2 nd frame start address for codec DMA	0

CR3 START ADDRESS REGISTER

Register	Address	R/W	Description	Reset Value
CICOCSA3	0x4F000040	RW	Cr 3 rd frame start address for codec DMA	0

CICOCSA3	Bit	Description	Initial State
CICOCSA3	[31:0]	Cr 3 rd frame start address for codec DMA	0

CR4 START ADDRESS REGISTER

Register	Address	R/W	Description	Reset Value
CICOCSA4	0x4F000044	RW	Cr 4 th frame start address for codec DMA	0

CICOCSA4	Bit	Description	Initial State
CICOCSA4	[31:0]	Cr 4 th frame start address for codec DMA	0

CODEC TARGET FORMAT REGISTER

Register	Address	R/W	Description	Reset Value
CICOTRGFMT	0x4F000048	RW	Target image format of codec DMA	0

CICOTRGFMT	Bit	Description	Initial State
In422_Co	[31]	0 = YCbCr 4:2:0 codec scaler input image format. In this case, horizontal line decimation is performed before codec scaler. (normally used) 1 = YCbCr 4:2:2 codec scaler input image format.	0
Out422_Co	[30]	0 = YCbCr 4:2:0 codec scaler output image format. This mode is mainly for MPEG-4 codec & H/W JPEG DCT (normally used) 1 = YCbCr 4:2:2 codec scaler output image format. This mode is mainly for S/W JPEG.	0
TargetHsize_Co	[28:16]	Horizontal pixel number of target image for codec DMA (multiple of 16)	0
FlipMd_Co	[15:14]	Image mirror and rotation for codec DMA 00 = Normal 01 = X-axis mirror 10 = Y-axis mirror 11 = 180° rotation	0
TargetVsize_Co	[12:0]	Vertical pixel number of target image for codec DMA	0

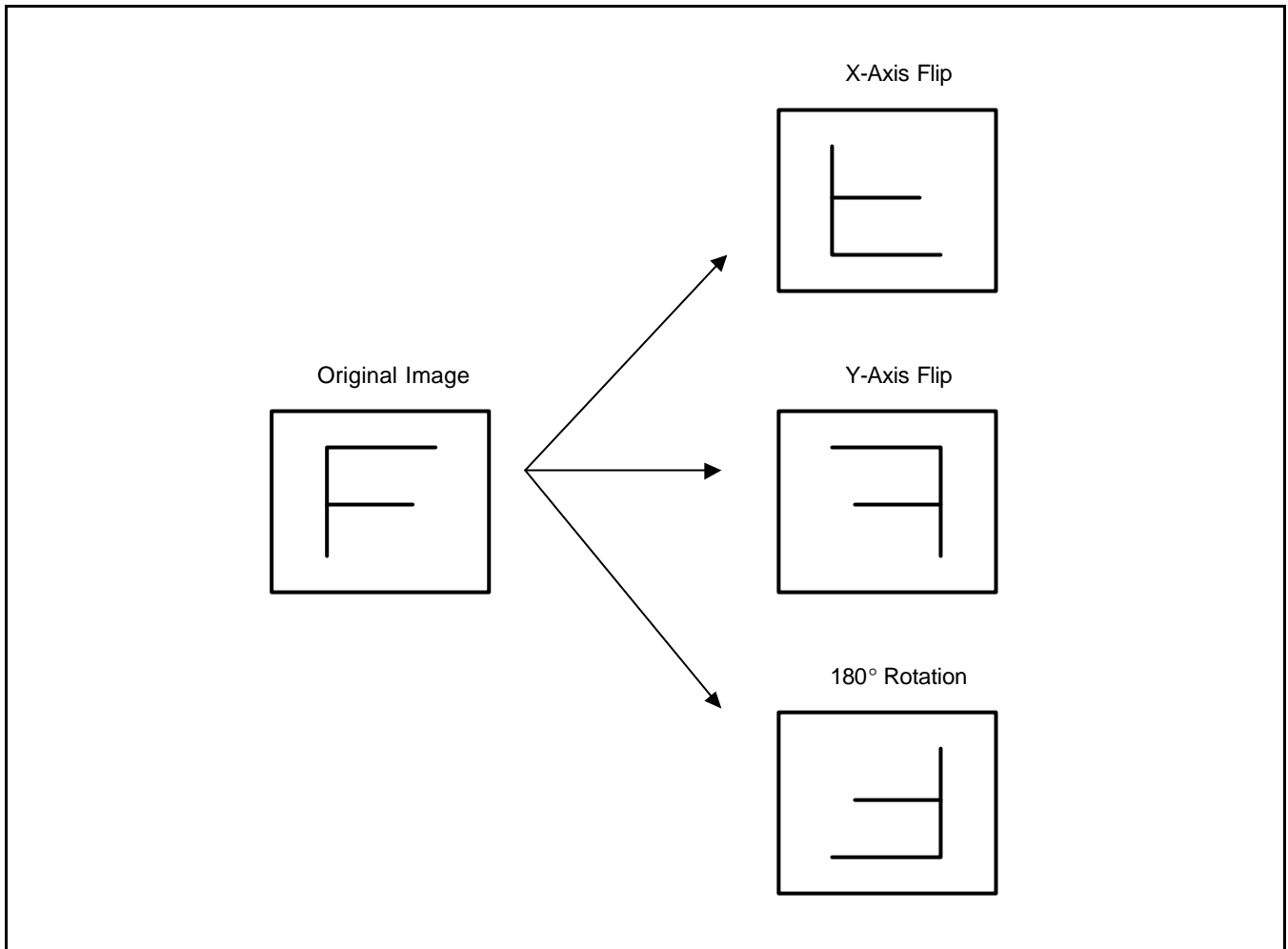

Figure 23-11. Image Mirror and Rotation

CODEC DMA CONTROL REGISTER

Register	Address	R/W	Description	Reset Value
CICOCTRL	0x4F00004C	RW	Codec DMA control related	0

CICOCTRL	Bit	Description	Initial State
Yburst1_Co	[23:19]	Main burst length for codec Y frames	0
Yburst2_Co	[18:14]	Remained burst length for codec Y frames	0
Cburst1_Co	[13:9]	Main burst length for codec Cb/Cr frames	0
Cburst2_Co	[8:4]	Remained burst length for codec Cb/Cr frames	0
LastIRQEn_Co	[2]	0 = normal 1 = enable last IRQ at the end of the frame capture (This bit is cleared automatically)	0

NOTE: All burst lengths must be one of the 2, 4, 8, 16.

Example 1: Target image size: QCIF (horizontal Y width = 176 pixels. 1 pixel = 1 Byte. 1 word = 4 pixel)

$$176 / 4 = 44 \text{ word}$$

$$44 \% 8 = 4 \rightarrow \text{main burst} = 8, \text{remained burst} = 4$$

Example 2: Target image size: VGA (horizontal Y width = 640 pixels. 1 pixel = 1 Byte. 1 word = 4 pixel)

$$640 / 4 = 160 \text{ word}$$

$$160 \% 16 = 0 \rightarrow \text{main burst} = 16, \text{remained burst} = 16$$

Example 3: Target image size: QCIF (horizontal C width = 88 pixels. 1 pixel = 1 Byte. 1 word = 4 pixel)

$$88 / 4 = 22 \text{ word}$$

$$22 \% 4 = 2 \rightarrow \text{main burst} = 4, \text{remained burst} = 2 \text{ (HTRANS==INCR)}$$

REGISTER SETTING GUIDE FOR CODEC SCALER AND PREVIEW SCALER

SRC_Width and **DST_Width** satisfy the word boundary constraints such that the number of horizontal pixel can be represented to kn where $n = 1, 2, 3, \dots$ and $k = 1 / 2 / 8$ for 24bppRGB / 16bppRGB / YCbCr420 image, respectively. TargetHsize should not be larger than SourceHsize. Similarly, TargetVsize should not be larger than SourceVsize.

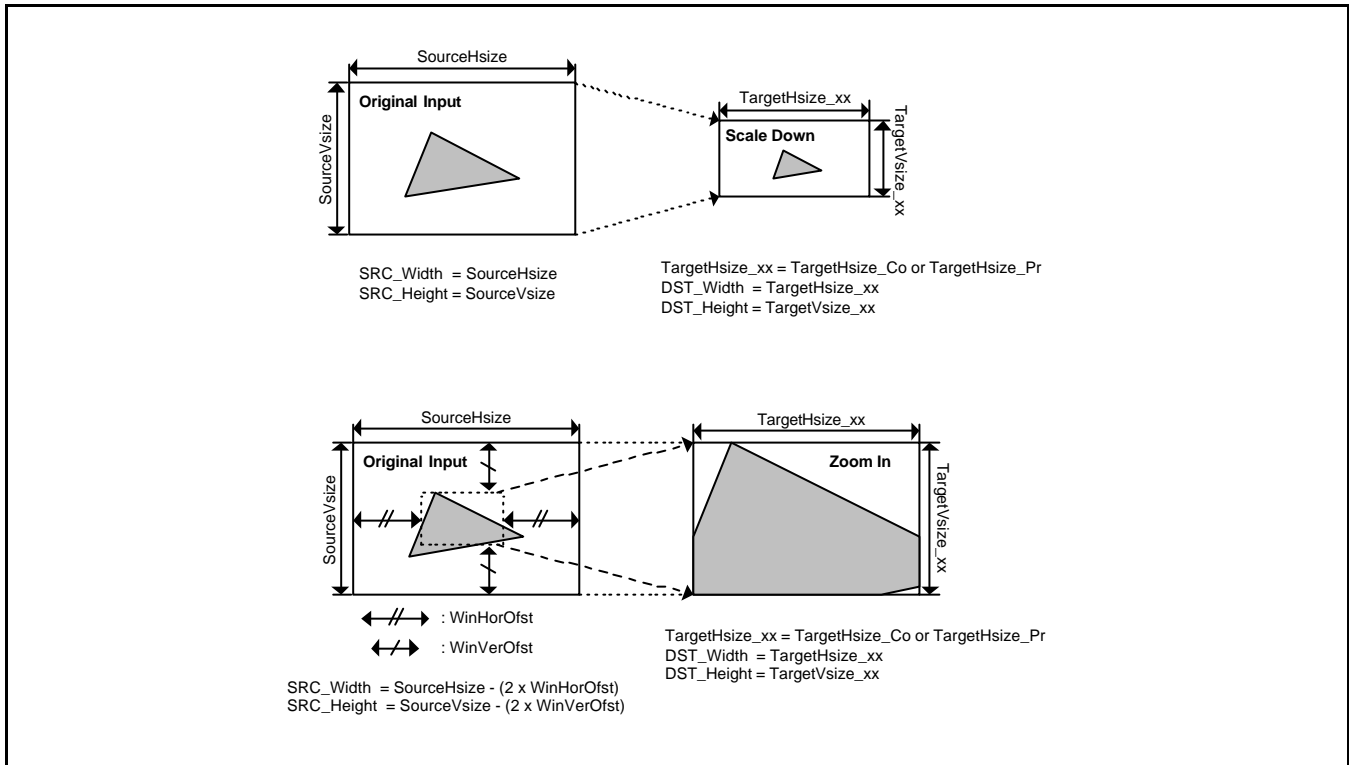

Figure 23-12. Scaling Scheme

The other control registers of pre-scaled like image size, pre-scale ratio, pre-scale shift ratio and main scale ratio are defined according to the following equations.

```

If ( SRC_Width >= 64 x DST_Width ) { Exit(-1); /* Out Of Horizontal Scale Range */ }
else if ( SRC_Width >= 32 x DST_Width ) { PreHorRatio_xx = 32; H_Shift = 5; }
else if ( SRC_Width >= 16 x DST_Width ) { PreHorRatio_xx = 16; H_Shift = 4; }
else if ( SRC_Width >= 8 x DST_Width ) { PreHorRatio_xx = 8; H_Shift = 3; }
else if ( SRC_Width >= 4 x DST_Width ) { PreHorRatio_xx = 4; H_Shift = 2; }
else if ( SRC_Width >= 2 x DST_Width ) { PreHorRatio_xx = 2; H_Shift = 1; }
else { PreHorRatio_xx = 1; H_Shift = 0; }

PreDstWidth_xx = SRC_Width / PreHorRatio_xx;
MainHorRatio_xx = ( SRC_Width << 8 ) / ( DST_Width << H_Shift);

```

```

If ( SRC_Height >= 64 × DST_Height ) { Exit(-1); /* Out Of Vertical Scale Range */ }
else if (SRC_Height >= 32 × DST_Height) { PreVerRatio_xx = 32; V_Shift = 5; }
else if (SRC_Height >= 16 × DST_Height) { PreVerRatio_xx = 16; V_Shift = 4; }
else if (SRC_Height >= 8 × DST_Height) { PreVerRatio_xx = 8; V_Shift = 3; }
else if (SRC_Height >= 4 × DST_Height) { PreVerRatio_xx = 4; V_Shift = 2; }
else if (SRC_Height >= 2 × DST_Height) { PreVerRatio_xx = 2; V_Shift = 1; }
else { PreVerRatio_xx = 1; V_Shift = 0; }
PreDstHeight_xx = SRC_Height / PreVerRatio_xx;
MainVerRatio_xx = ( SRC_Height << 8 ) / ( DST_Height << V_Shift);
SHfactor_xx = 10 - ( H_Shift + V_Shift);

```

NOTE

Preview path contains 640 pixel line buffer. (Codec path contains 2048 pixel line buffer) So, upper 1280 pixels, input images must be pre-scaled by over 1/2 for capturing valid preview image. ((SourceHsize-2*WinHorOfst)/PreHorRatio_Pr) <= 640

CODEC PRE-SCALER CONTROL REGISTER 1

Register	Address	R/W	Description	Reset Value
CICOSCPREERATIO	0x4F000050	RW	Codec pre-scaler ratio control	0

CICOSCPREERATIO	Bit	Description	Initial State
SHfactor_Co	[31:28]	Shift factor for codec pre-scaler	0
PreHorRatio_Co	[22:16]	Horizontal ratio of codec pre-scaler	0
PreVerRatio_Co	[6:0]	Vertical ratio of codec pre-scaler	0

CODEC PRE-SCALER CONTROL REGISTER 2

Register	Address	R/W	Description	Reset Value
CICOSCPREDST	0x4F000054	RW	Codec pre-scaler destination format	0

CICOSCPREDST	Bit	Description	Initial State
PreDstWidth_Co	[27:16]	Destination width for codec pre-scaler	0
PreDstHeight_Co	[11:0]	Destination height for codec pre-scaler	0

CODEC MAIN-SCALER CONTROL REGISTER

Register	Address	R/W	Description	Reset Value
CICOSCTRL	0x4F000058	RW	Codec main-scaler control	0

CICOSCTRL	Bit	Description	Initial State
ScalerBypass_Co	[31]	Codec scaler bypass for upper 2048 x 2048 size (In this case, ImgCptEn_CoSC and ImgCptEn_PrSC should be 0, but ImgCptEn should be 1. It is not allowed to capture preview image. This mode is intended to capture JPEG input image for DSC application) In this case, input pixel buffering depends on only input FIFOs, so the system bus should be not busy in this mode.	0
ScaleUpDown_Co	[30:29]	Scale up/down flag for codec scaler (In 1:1 scale ratio, this bit should be "1") 00 = Down 11 = Up	00
MainHorRatio_Co	[24:16]	Horizontal scale ratio for codec main-scaler	0
CoScalerStart	[15]	Codec scaler start	0
MainVerRatio_Co	[8:0]	Vertical scale ratio for codec main-scaler	0

CODEC DMA TARGET AREA REGISTER

Register	Address	R/W	Description	Reset Value
CICOTAREA	0x4F00005C	RW	Codec scaler target area	0

CICOTAREA	Bit	Description	Initial State
CICOTAREA	[25:0]	Target area for codec DMA = Target H size x Target V size	0

CODEC STATUS REGISTER

Register	Address	R/W	Description	Reset Value
CICOSTATUS	0x4F000064	R	Codec path status	0

CICOSTATUS	Bit	Description	Initial State
OvFiY_Co	[31]	Overflow state of codec source FIFO Y	0
OvFiCb_Co	[30]	Overflow state of codec source FIFO Cb	0
OvFiCr_Co	[29]	Overflow state of codec source FIFO Cr	0
VSYNC	[28]	Camera VSYNC (This bit can be referred by CPU for first SFR setting. And, it can be seen in the ITU-R BT 656 mode, too)	0
FrameCnt_Co	[27:26]	Frame count of codec DMA (This counter value indicates the next frame number)	0
WinOfstEn_Co	[25]	Window offset enable status	0
FlipMd_Co	[24:23]	Flip mode of codec DMA	0
ImgCptEn_CamIf	[22]	Image capture enable of camera interface	0
ImgCptEn_CoSC	[21]	Image capture enable of codec path	0

RGB1 START ADDRESS REGISTER

Register	Address	R/W	Description	Reset Value
CIPRCLRSA1	0x4F00006C	RW	RGB 1 st frame start address for preview DMA	0

CIPRCLRSA1	Bit	Description	Initial State
CIPRCLRSA1	[31:0]	RGB 1 st frame start address for preview DMA	0

RGB2 START ADDRESS REGISTER

Register	Address	R/W	Description	Reset Value
CIPRCLRSA2	0x4F000070	RW	RGB 2 nd frame start address for preview DMA	0

CIPRCLRSA2	Bit	Description	Initial State
CIPRCLRSA2	[31:0]	RGB 2 nd frame start address for preview DMA	0

RGB3 START ADDRESS REGISTER

Register	Address	R/W	Description	Reset Value
CIPRCLRSA3	0x4F000074	RW	RGB 3 rd frame start address for preview DMA	0

CIPRCLRSA3	Bit	Description	Initial State
CIPRCLRSA3	[31:0]	RGB 3 rd frame start address for preview DMA	0

RGB4 START ADDRESS REGISTER

Register	Address	R/W	Description	Reset Value
CIPRCLRSA4	0x4F000078	RW	RGB 4 th frame start address for preview DMA	0

CIPRCLRSA4	Bit	Description	Initial State
CIPRCLRSA4	[31:0]	RGB 4 th frame start address for preview DMA	0

PREVIEW TARGET FORMAT REGISTER

Register	Address	R/W	Description	Reset Value
CIPRTRGFMT	0x4F00007C	RW	Target image format of preview DMA	0

CIPRTRGFMT	Bit	Description	Initial State
TargetHsize_Pr	[28:16]	Horizontal pixel number of target image for preview DMA (even)	0
FlipMd_Pr	[15:14]	Image mirror and rotation for preview DMA 00 = Normal 01 = X-axis mirror 10 = Y-axis mirror 11 = 180° rotation	0
TargetVsize_Pr	[12:0]	Vertical pixel number of target image for preview DMA	0

PREVIEW DMA CONTROL REGISTER

Register	Address	R/W	Description	Reset Value
CIPRCTRL	0x4F000080	RW	Preview DMA control related	0

CIPRCTRL	Bit	Description	Initial State
RGBburst1_Pr	[23:19]	Main burst length for preview RGB frames	0
RGBburst2_Pr	[18:14]	Remained burst length for preview RGB frames	0
LastIRQEn_Pr	[2]	0 = Normal 1 = Enable last IRQ at the end of frame capture. (This bit is cleared automatically.)	0

NOTE: All burst lengths must be one of the 2, 4, 8, 16.

Example 1: Target image size: QCIF for RGB 32-bit format (horizontal width = 176 pixels. 1 pixel = 1 word)

176 pixel = 176 word.

$176 \% 16 = 0 \rightarrow$ main burst = 16, remained burst = 16

Example 2: Target image size: VGA for RGB 16-bit format (horizontal width = 640 pixels. 2 pixel = 1 word)

$640 / 2 = 320$ word

$160 \% 16 = 0 \rightarrow$ main burst = 16, remained burst = 16

PREVIEW PRE-SCALER CONTROL REGISTER 1

Register	Address	R/W	Description	Reset Value
CIPRSCPRERATIO	0x4F000084	RW	Preview pre-scaler ratio control	0

CIPRSCPRERATIO	Bit	Description	Initial State
SHfactor_Pr	[31:28]	Shift factor for preview pre-scaler	0
PreHorRatio_Pr	[22:16]	Horizontal ratio of preview pre-scaler	0
PreVerRatio_Pr	[6:0]	Vertical ratio of preview pre-scaler	0

PREVIEW STATUS REGISTER

Register	Address	R/W	Description	Reset Value
CIPRSTATUS	0x4F000098	R	Preview path status	0

CIPRSTATUS	Bit	Description	Initial State
OvFiCb_Pr	[31]	Overflow state of preview source FIFO Cb	0
OvFiCr_Pr	[30]	Overflow state of preview source FIFO Cr	0
FrameCnt_Pr	[27:26]	Frame count of preview DMA	0
FlipMd_Pr	[24:23]	Flip mode of preview DMA	0
ImgCptEn_PrSC	[21]	Image capture enable of preview path	0

IMAGE CAPTURE ENABLE REGISTER

This register must be set at last.

Register	Address	R/W	Description	Reset Value
CIIMGCPT	0x4F0000A0	RW	Image capture enable command	0

CIGCTRL	Bit	Description	Initial State
ImgCptEn	[31]	Camera interface global capture enable	0
ImgCptEn_CoSc	[30]	Capture enable for codec scaler. This bit must be '0' in scaler bypass mode.	0
ImgCptEn_PrSc	[29]	Capture enable for preview scaler This bit must be '0' in scaler bypass mode.	0

NOTES

24

AC97 CONTROLLER

OVERVIEW

The AC97 Controller Unit of the S3C2440A supports AC97 revision 2.0 features. AC97 Controller communicates with AC97 Codec using an audio controller link (AC-link). Controller sends the stereo PCM data to Codec. The external digital-to-analog converter (DAC) in the Codec then converts the audio sample to an analog audio waveform. Also, the Controller receives the stereo PCM data and the mono Mic data from the Codec and then stores them in the memories. This chapter describes the programming model for the AC97 Controller Unit. The information in this chapter requires an understanding of the AC97 revision 2.0 specifications.

NOTE

The AC97 Controller and the I²S Controller must not be used at the same time.

FEATURES

- Independent channels for stereo PCM In, stereo PCM Out, mono MIC In.
- DMA-based operation and interrupt based operation.
- All of the channels support only 16-bit samples.
- Variable sampling rate AC97 Codec interface (48 KHz and below)
- 16-bit, 16 entry FIFOs per channel
- Only Primary CODEC support

AC97 CONTROLLER OPERATION

BLOCK DIAGRAM

Figure 24-1 shows the functional block diagram of the S3C2440A AC97 Controller. The AC97 signals form the AC-link, which is a point-to-point synchronous serial interconnect that supports full-duplex data transfers. All digital audio streams and command/status information are communicated over the AC-link.

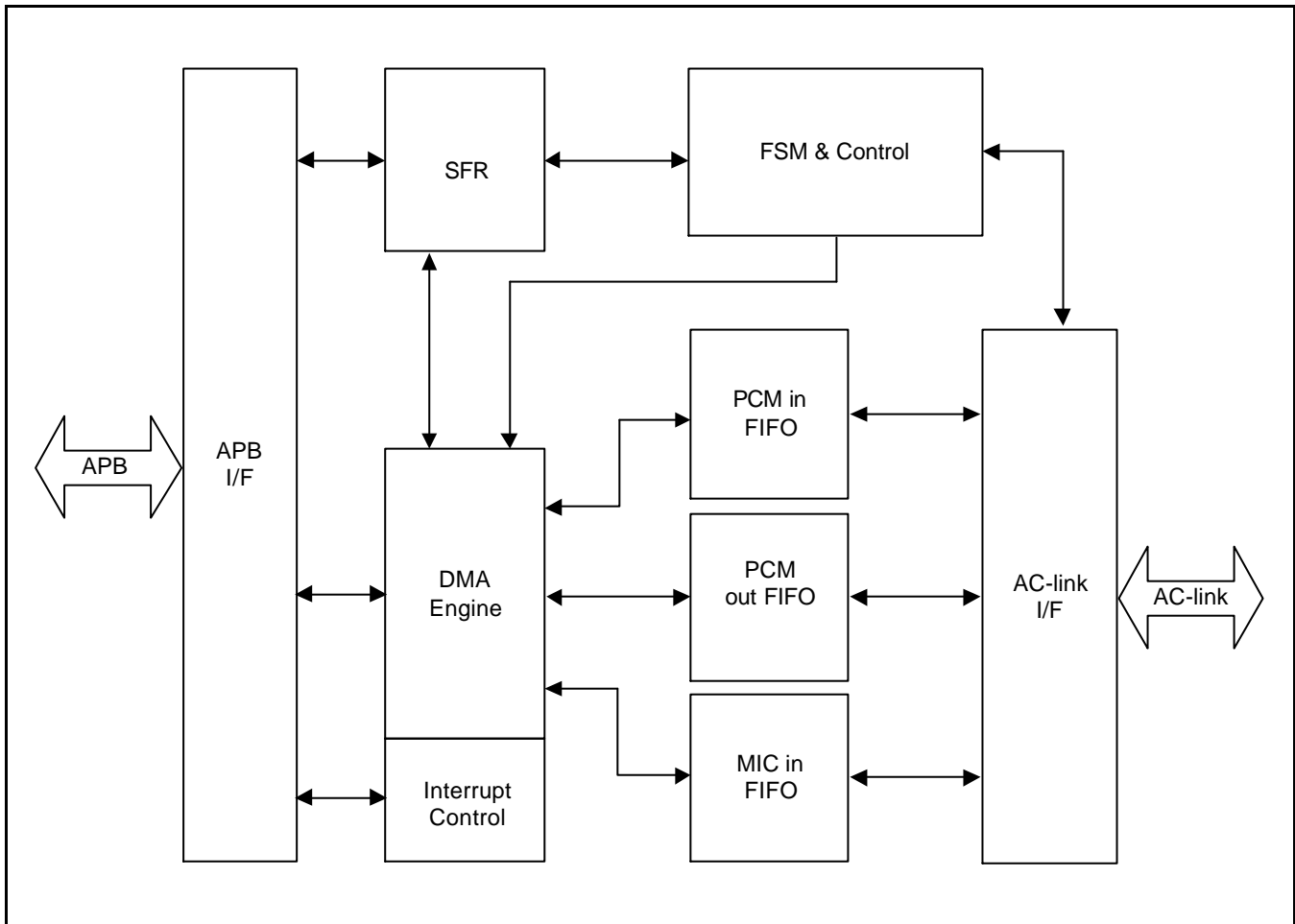

Figure 24-1. AC97 Block Diagram

INTERNAL DATA PATH

Figure 24-2 shows the internal data path of the S3C2440A AC97 Controller. It has stereo Pulse Code Modulated (PCM) In, Stereo PCM Out and mono Mic-in buffers, which consist of 16-bit, 16 entries buffer. Also it has a 20-bit I/O shift register via AC-link.

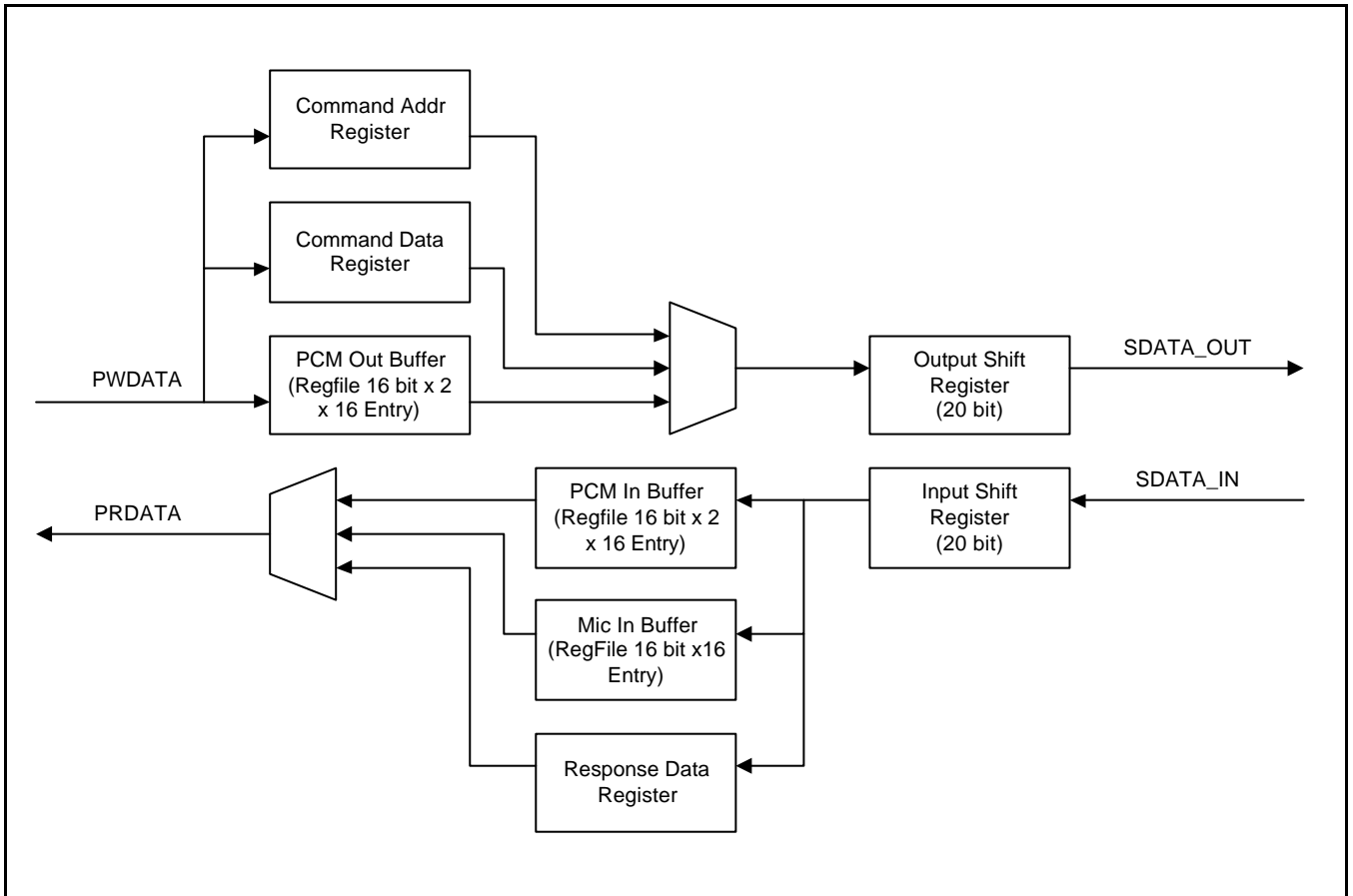

Figure 24-2. Internal Data Path

OPERATION FLOW CHART

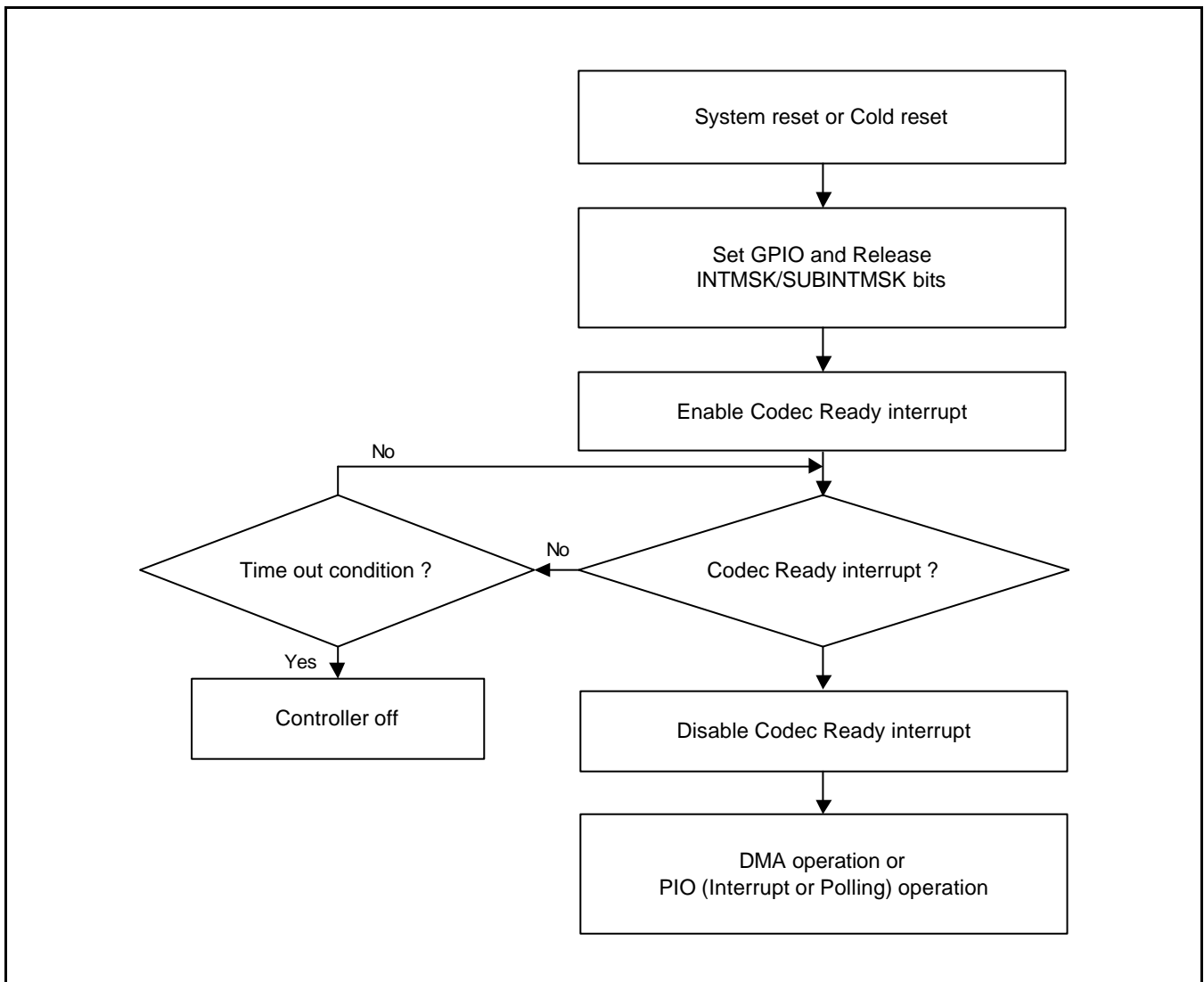

Figure 24-3. AC97 Operation Flow Chart

AC-LINK DIGITAL INTERFACE PROTOCOL

Each AC97 Codec incorporates a five-pin digital serial interface that links it to the S3C2440A AC97 Controller. The AC-link is a full-duplex, fixed-clock, PCM digital stream. It employs a time division multiplexing (TDM) scheme to handle control register access and multiple input and output audio streams. The AC-link architecture divides each audio frame into 12 outgoing and 12 incoming data streams. Each stream has a 20-bit sample resolution and requires a DAC and an analog-to-digital converter (ADC) with a minimum of 16-bit resolution.

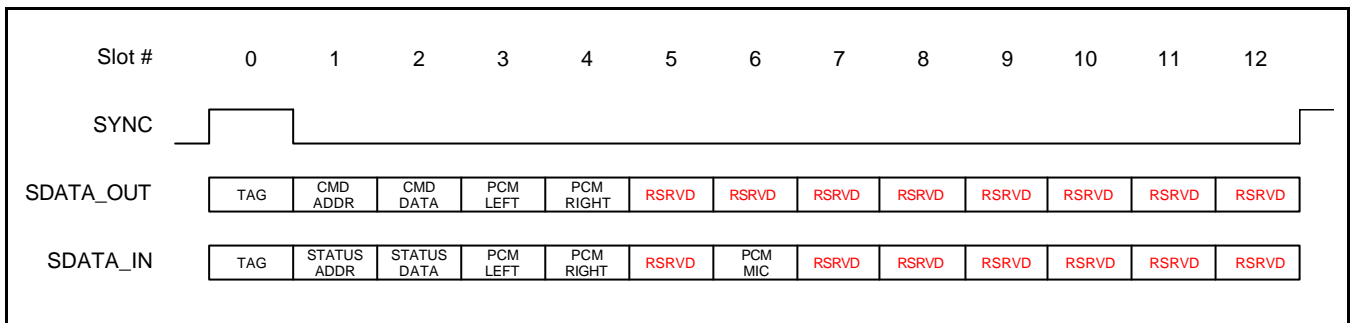

Figure 24-4. Bi-directional AC-link Frame with Slot Assignments

Figure 24-4 shows the slot definitions supported by the S3C2440A AC97 Controller. The S3C2440A AC97 Controller provides synchronization for all data transaction on the AC-link.

A data transaction is made up of 256-bits of information broken up into groups of 13 time slots and is called a frame. Time slot 0 is called as Tag Phase and it is 16-bits long. The remaining 12 time slots are called as Data Phase. The Tag Phase contains a bit that identifies a valid frame and 12-bits that identify the time slots in the Data Phase that contain a valid data. Each time slot in the Data Phase is 20-bits long. A frame begins when the SYNC goes high. The amount of time the SYNC is high corresponds to the Tag Phase.

AC97 frames occur at fixed 48 kHz intervals and are synchronous to the 12.288 MHz bit rate clock, BITCLK. The controller and the CODEC use the SYNC and BITCLK to determine when to send the transmit data and when to sample the received data. A transmitter transitions the serial data stream on each rising edge of BITCLK and a receiver samples the serial data stream on falling edges of BITCLK. The transmitter must tag the valid slots in its serial data stream. The valid slots are tagged in slot 0. Serial data on the AC-link is from MSB to LSB. The Tag Phase's first bit is bit 15 and the first bit of each slot in the Data Phase is bit 19. The last bit in any slot is bit 0.

AC-LINK OUTPUT FRAME (SDATA_OUT)

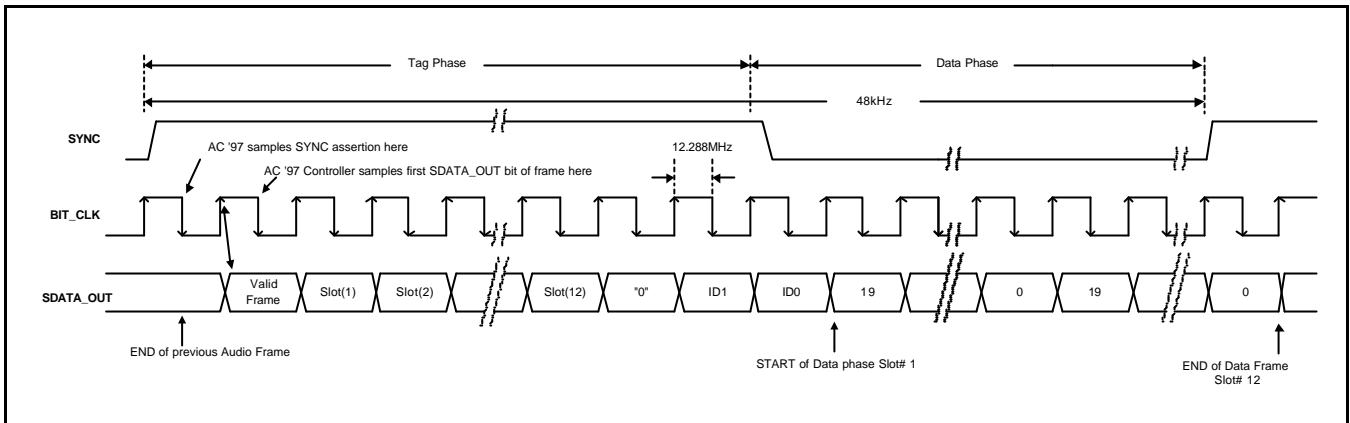

Figure 24-5. AC-link Output Frame

AC-LINK INPUT FRAME (SDATA_IN)

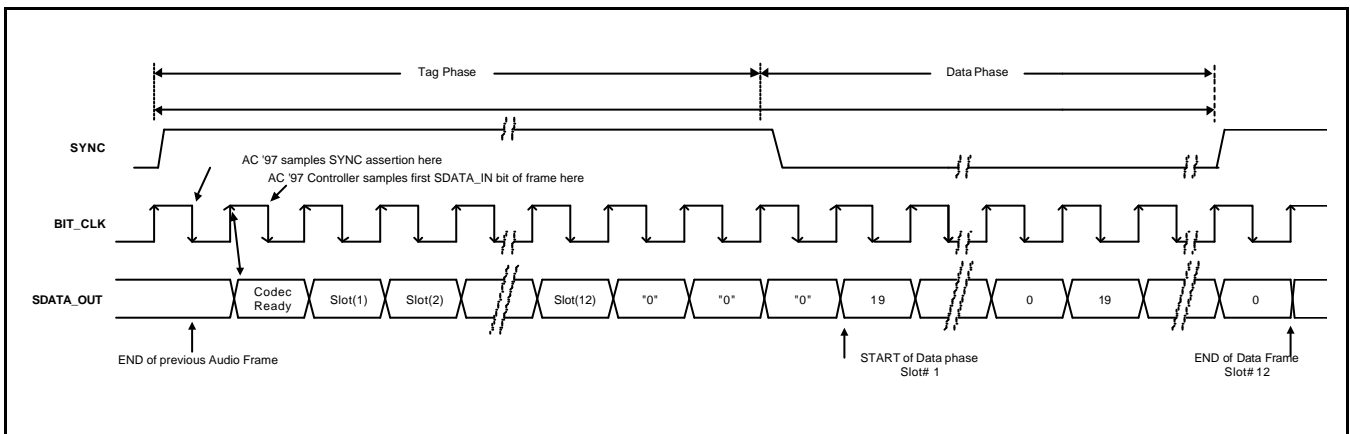

Figure 24-6. AC-link Input Frame

AC97 POWERDOWN

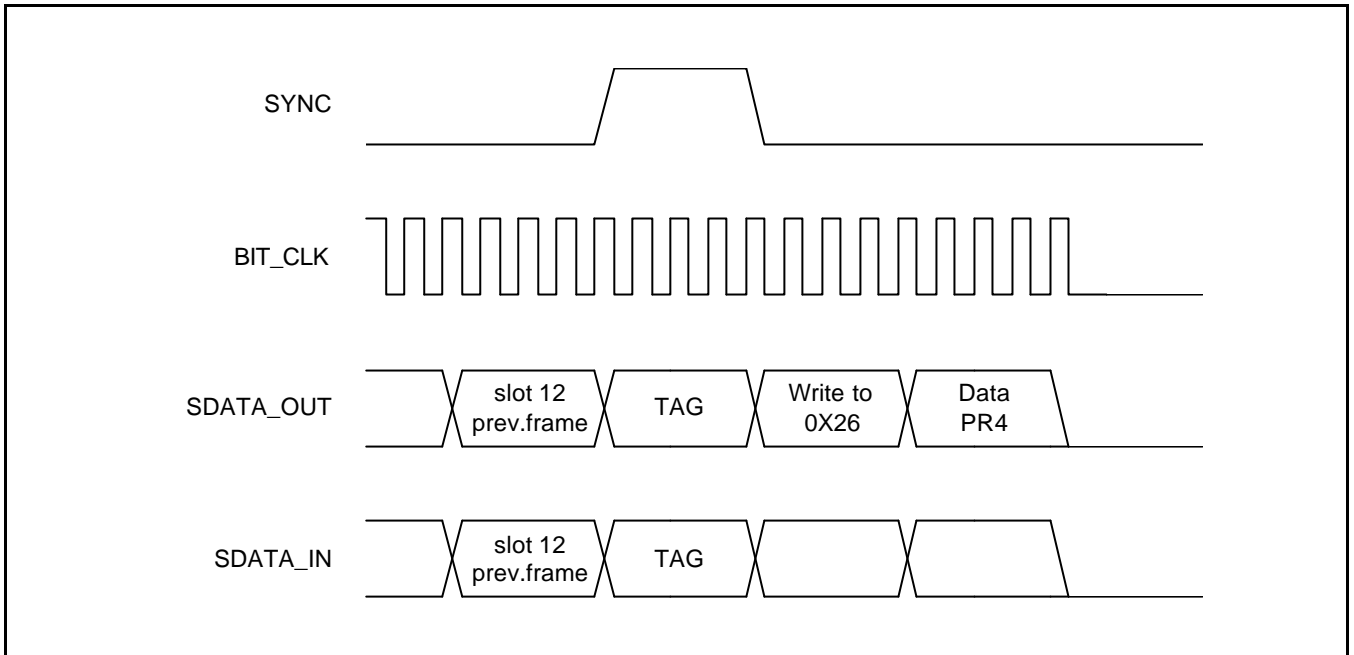

Figure 24-7. AC97 Powerdown Timing Diagram

Powering Down the AC-link

The AC-link signals enter a low power mode when the AC97 CODEC Powerdown register (0x26) bit PR4 is set to 1 (i.e. by writing 0x1000). Then the Primary CODEC drives both the BITCLK and SDATA_IN to a logic low voltage level. The sequence follows the timing diagram shown above in the Figure 24-7.

The AC97 Controller transmits the write to Powerdown register (0x26) over the AC-link. Set up the AC97 Controller so that it does not transmit data to slots 3-12 when it writes to the Powerdown register bit PR4 (data 0x1000), and it does not require the CODEC to process other data when it receives a power down request. When the CODEC processes the request, it immediately transitions BITCLK and SDATA_IN to a logic low level. The AC97 Controller drives the SYNC and SDATA_OUT to a logic low level after programming the AC_GLBCTRL register.

Waking up the AC-link - Wake Up Triggered by the AC97 Controller

AC-link protocol is provided for a cold AC97 reset and a warm AC97 reset. The current power-down state ultimately dictates which AC97 reset is used. Registers must stay in the same state during all power-down modes unless a cold AC97 reset is performed. In a cold AC97 reset, the AC97 registers are initialized to their default values. After a power down, the AC-link must wait for a minimum of four audio frame time after the frame in which the power down occurred before it can be reactivated by reasserting the SYNC signal. When AC-link powers up, it indicates readiness through the Codec ready bit (input slot 0, bit 15).

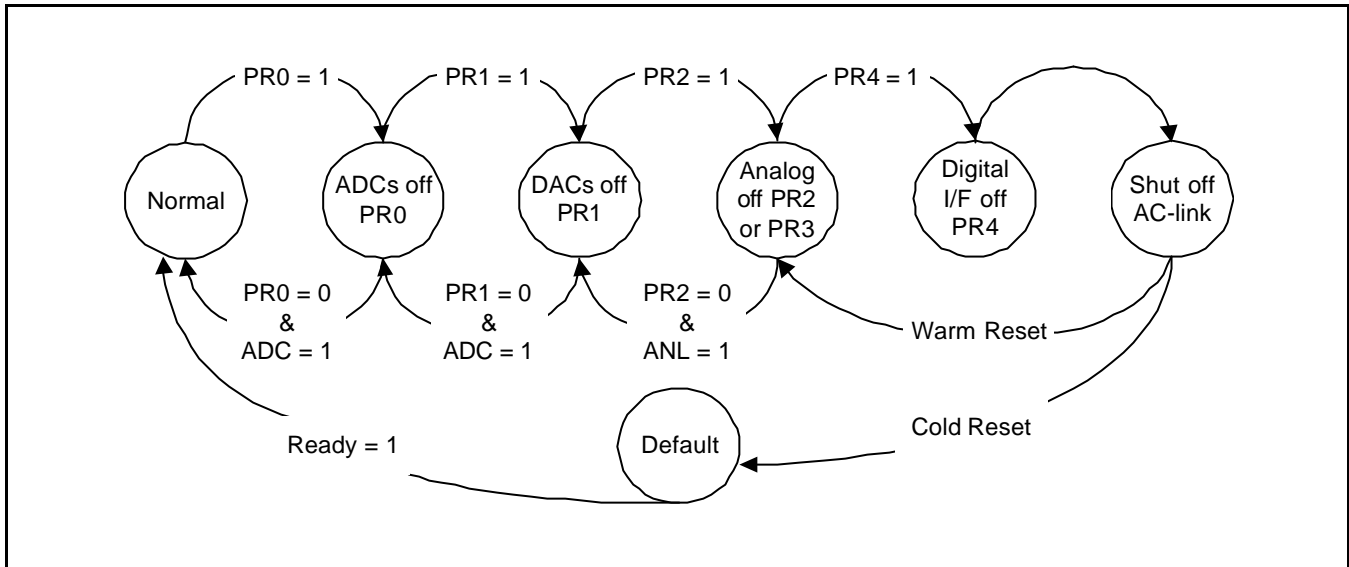

Figure 24-8. AC97 Power down/Power up Flow

Cold AC97 Reset

A cold reset is generated when an nRESET pin is asserted through the AC_GLBCTRL. Asserting and de-asserting nRESET activates the BITCLK and SDATA_OUT. All the AC97 control registers are initialized to their default power on reset values. nRESET is an asynchronous AC97 input.

Warm AC97 Reset

A warm AC97 reset reactivates the AC-link without altering the current AC97 register values. A warm reset is generated when BITCLK is absent and SYNC is driven high. In normal audio frames, SYNC is a synchronous AC97 input. When BITCLK is absent, SYNC is treated as an asynchronous input used to generate a warm reset to AC97. The AC97 Controller must not activate BITCLK until it samples the SYNC to low again. This prevents a new audio frame from being falsely detected.

AC97 CONTROLLER SPECIAL REGISTERS

AC97 GLOBAL CONTROL REGISTER (AC_GLBCTRL)

Register	Address	R/W	Description	Reset Value
AC_GLBCTRL	0x5B000000	R/W	AC97 global control register	0x000000

AC_GLBCTRL	Bit	Description	Initial State
Reserved	[31:23]	–	0x00
Codec ready interrupt enable	[22]	0: Disable 1: Enable	0
PCM out channel underrun interrupt enable	[21]	0: Disable 1: Enable (FIFO is empty)	0
PCM in channel overrun interrupt Enable	[20]	0 : Disable 1 : Enable (FIFO is full)	0
MIC in channel overrun interrupt enable	[19]	0: Disable 1: Enable (FIFO is full)	0
PCM out channel threshold interrupt enable	[18]	0: Disable 1: Enable (FIFO is half empty)	0
PCM in channel threshold interrupt enable	[17]	0: Disable 1: Enable (FIFO is half full)	0
MIC in channel threshold interrupt enable	[16]	0: Disable 1: Enable (FIFO is half full)	0
Reserved	[15:14]	–	00
PCM out channel transfer mode	[13:12]	00: Off 01: PIO 10: DMA 11: Reserved	00
PCM in channel transfer mode	[11:10]	00: Off 01: PIO 10: DMA 11: Reserved	00
MIC in channel transfer mode	[9:8]	00: Off 01: PIO 10: DMA 11: Reserved	00
Reserved	[7:4]	–	0000
Transfer data enable using AC-link	[3]	0: Disable 1: Enable	0
AC-link on	[2]	0: Off 1: SYNC signal transfer to Codec	0
Warm reset	[1]	0: Normal 1: Wake up codec from power down	0
Cold reset	[0]	0: Normal 1: Reset Codec and Controller logic	0

AC97 GLOBAL STATUS REGISTER (AC_GLBSTAT)

Register	Address	R/W	Description	Reset Value
AC_GLBSTAT	0x5B000004	R	AC97 global status register	0x00000000

AC_GLBSTAT	Bit	Description	Initial State
Reserved	[31:23]	–	0x00
Codec ready interrupt	[22]	0: Not requested 1: Requested	0
PCM out channel underrun interrupt	[21]	0: Not requested 1: Requested	0
PCM in channel overrun Interrupt	[20]	0: Not requested 1: Requested	0
MIC in channel overrun interrupt	[19]	0: Not requested 1: Requested	0
PCM out channel threshold interrupt	[18]	0: Not requested 1: Requested	0
PCM in channel threshold interrupt	[17]	0: Not requested 1: Requested	0
MIC in channel threshold interrupt	[16]	0: Not requested 1: Requested	0
Reserved	[15:3]	–	0x000
Controller main state	[2:0]	000: Idle 001: Init 010: Ready 011: Active 100: LP 101: Warm	000

AC97 CODEC COMMAND REGISTER (AC_CODEC_CMD)

Register	Address	R/W	Description	Reset Value
AC_CODEC_CMD	0x5B000008	R/W	AC97 codec command register	0x00000000

AC_CODEC_CMD	Bit	Description	Initial State
Reserved	[31:24]	–	0x00
Read enable	[23]	0: Command write (NOTE) 1: Status read	0
Address	[22:16]	CODEC command address	0x00
Data	[15:0]	CODEC command data	0x0000

NOTE: When the commands are written on the AC_CODDEC_CMD register, it is recommended that the delay time between the command and the next command is more than 1/48 Hz.

AC97 CODEC STATUS REGISTER (AC_CODEC_STAT)

Register	Address	R/W	Description	Reset Value
AC_CODEC_STAT	0x5B00000C	R	AC97 codec status register	0x00000000

AC_CODEC_STAT	Bit	Description	Initial State
Reserved	[31:23]	–	0x00
Address	[22:16]	CODEC status address	0x00
Data	[15:0]	CODEC status data	0x0000

NT0ES:

If you want to read data from AC97 codec register via the AC_CODEC_STAT register, you should follow these steps.

1. Write command address and data on the AC_CODEC_CMD register with Bit [23] =1.
2. Have a delay time.
3. Read command address and data from AC_CODEC_STAT register.

AC97 PCM OUT/IN CHANNEL FIFO ADDRESS REGISTER (AC_PCMADDR)

Register	Address	R/W	Description	Reset Value
AC_PCMADDR	0x5B000010	R	AC97 PCM out/in channel FIFO address register	0x00000000

AC_PCMADDR	Bit	Description	Initial State
Reserved	[31:28]	–	0000
Out read address	[27:24]	PCM out channel FIFO read address	0000
Reserved	[23:20]	–	0000
In read address	[19:16]	PCM in channel FIFO read address	0000
Reserved	[15:12]	–	0000
Out write address	[11:8]	PCM out channel FIFO write address	0000
Reserved	[7:4]	–	0000
In write address	[3:0]	PCM in channel FIFO write address	0000

AC97 MIC IN CHANNEL FIFO ADDRESS REGISTER (AC_MICADDR)

Register	Address	R/W	Description	Reset Value
AC_MICADDR	0x5B000014	R	AC97 MIC in channel FIFO address register	0x00000000

AC_MICADDR	Bit	Description	Initial State
Reserved	[31:20]	–	0000
Read Address	[19:16]	MIC in channel FIFO read address	0000
Reserved	[15:4]	–	0x000
Write Address	[3:0]	MIC in channel FIFO write address	0000

AC97 PCM OUT/IN CHANNEL FIFO DATA REGISTER (AC_PCMDATA)

Register	Address	R/W	Description	Reset Value
AC_PCMDATA	0x5B000018	R/W	AC97 PCM out/in channel FIFO data register	0x00000000

AC_PCMDATA	Bit	Description	Initial State
Left Data	[31:16]	PCM out/in left channel FIFO data Read: PCM in left channel Write: PCM out left channel	0x0000
Right Data	[15:0]	PCM out/in right channel FIFO data Read: PCM in right channel Write: PCM out right channel	0x0000

AC97 MIC IN CHANNEL FIFO DATA REGISTER (AC_MICDATA)

Register	Address	R/W	Description	Reset Value
AC_MICDATA	0x5B00001C	R/W	AC97 MIC in channel FIFO data register	0x00000000

AC_MICDATA	Bit	Description	Initial State
Reserved	[31:16]	–	0x0000
Mono Data	[15:0]	MIC in mono channel FIFO data	0x0000

25

BUS PRIORITIES

OVERVIEW

The bus arbitration logic determines the priorities of bus masters. It supports a combination of rotation priority mode and fixed priority mode.

BUS PRIORITY MAP

The S3C2440A holds 13 bus masters. They include DRAM refresh controller, LCD_DMA, CAMIF DMA, DMA0, DMA1, DMA2, DMA3, USB_HOST_DMA, EXT_BUS_MASTER, Test interface controller (TIC) and ARM920T. The following list shows the priorities among these bus masters after a reset:

1. DRAM refresh controller
2. LCD_DMA
3. CAMIF codec DMA
4. CAMIF preview DMA
5. DMA0
6. DMA1
7. DMA2
8. DMA3
9. USB host DMA
10. External bus master
11. TIC
12. ARM920T
13. Reserved

Among these bus masters, the four DMAs (DMA0, DMA1, DMA2 and DMA3) operate under rotation priority, while the others run under fixed priority.

NOTES

26 MECHANICAL DATA

PACKAGE DIMENSIONS

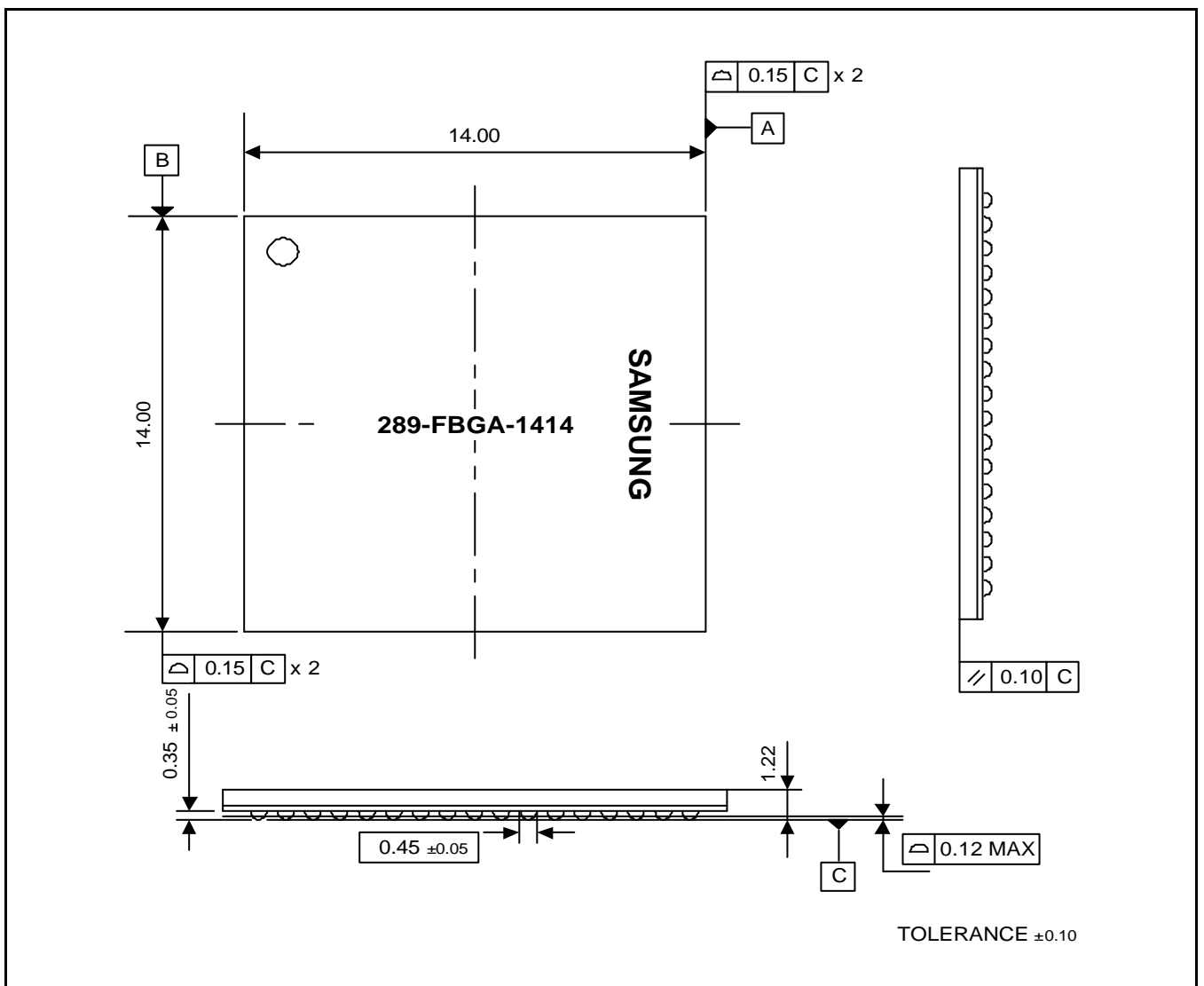

Figure 26-1. 289-FBGA-1414 Package Dimension 1 (Top View)

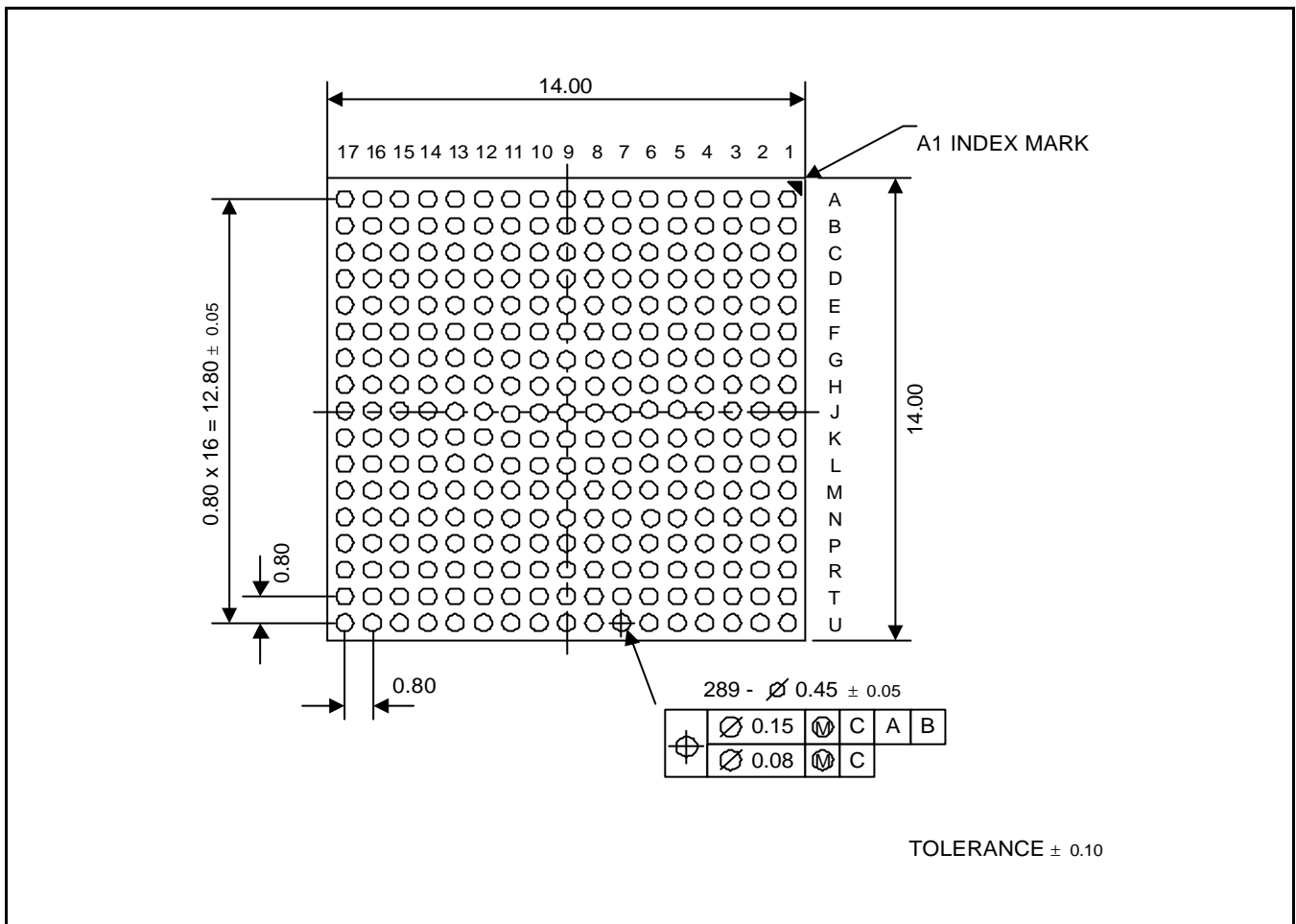

Figure 26-2. 289-FBGA-1414 Package Dimension 2 (Bottom View)

The recommended land open size is 0.39 – 0.41mm diameter.

27

ELECTRICAL DATA

ABSOLUTE MAXIMUM RATINGS

Table 27-1. Absolute Maximum Rating

Parameter	Symbol	Rating	Unit	
DC Supply Voltage	V_{DDi}	1.2V V_{DD}	1.8	V
	V_{DDOP}	3.3V V_{DD}	4.8	
	V_{DDMOP}	1.8V/2.5V/3.0V/3.3V V_{DD}	4.8	
	V_{DDRTC}	1.8V/2.5V/3.0V/3.3V V_{DD}	4.5	
	V_{DDADC}	3.3V V_{DD}	4.8	
DC Input Voltage	V_{IN}	3.3V Input buffer	4.8	
		3.3V Interface / 5V Tolerant input buffer	6.5	
DC Output Voltage	V_{OUT}	3.3V Output buffer	4.8	
DC Input (Latch-up) Current	I_{IN}	± 200		mA
Storage Temperature	T_{STG}	- 65 to 150		$^{\circ}\text{C}$

RECOMMENDED OPERATING CONDITIONS

Table 27-2. Recommended Operating Conditions

Parameter	Symbol	Rating			Unit
		Typ.	Min	Max	
DC supply voltage for alive block	$V_{DD\text{alive}}$	300MHz: 1.2V V_{DD} 400MHz: 1.3V V_{DD}	1.15 1.15	1.25 1.35	V
DC supply voltage for internal	$V_{DDi}^{(1)}$ $V_{DDiarm}^{(1)}$ V_{DDMPLL} V_{DDUPLL}	300MHz: 1.2V V_{DD} 400MHz: 1.3V V_{DD}	1.15 1.25	1.25 1.35	
DC supply voltage for I/O block	V_{DDOP}	3.3V V_{DD}	3.0	3.6	
DC supply voltage for memory interface	V_{DDMOP}	1.8V/2.5V/3.0V/3.3V V_{DD}	1.7	3.6	
DC supply voltage for analog core	V_{DD}	3.3V V_{DD}	3.0	3.6	
DC supply voltage for RTC	V_{DDRTC}	1.8V/2.5V/3.0V/3.3V V_{DD}	1.8	3.6	
DC input voltage	V_{IN}	3.3V Input buffer	- 0.3	$V_{DDOP}+0.3$	
		3.3V Interface / 5V Tolerant input buffer	- 0.3	5.25	
DC output voltage	V_{OUT}	3.3V Output buffer	- 0.3	$V_{DDOP}+0.3$	
Operating temperature	T_{OPR}	Industrial	-40 to 85		

NOTE: In the DVS(Dynamic Voltage Scaling) V_{DDi} & V_{DDiarm} can be supplied with 1.0V in Idle mode. Refer the Application

Notes for detailed information.

D.C. ELECTRICAL CHARACTERISTICS

Table 27-3 and 27-4 defines the DC electrical characteristics for the standard LVCMOS I/O buffers.

Table 27-3. Normal I/O PAD DC Electrical Characteristics

Normal I/O PAD DC Electrical Characteristics for Memory ($V_{DDMOP} = 2.5V \pm 0.2V$, $T_A = -40$ to 85 °C)

Symbol	Parameters	Condition	Min	Typ.	Max	Unit
V_{IH}	High level input voltage					V
	LVCMOS interface		1.7			
V_{IL}	Low level input voltage					V
	LVCMOS interface				0.7	
V_T	Switching threshold			$0.5V_{DD}$		V
V_{T+}	Schmitt trigger, positive-going threshold	CMOS			2.0	V
V_{T-}	Schmitt trigger, negative-going threshold	CMOS	0.8			V
I_{IH}	High level input current					μA
	Input buffer	$V_{IN} = V_{DD}$	-10		10	
I_{IL}	Low level input current					μA
	Input buffer	$V_{IN} = V_{SS}$	-10		10	
	Input buffer with pull-up		-60	-33	-10	
V_{OH}	High level output voltage					V
	Type B4 to B12	$I_{OH} = -1 \mu A$	$V_{DD} - 0.05$			
	Type B4	$I_{OH} = -4 \text{ mA}$	2.0			
	Type B6	$I_{OH} = -6 \text{ mA}$				
	Type B8	$I_{OH} = -8 \text{ mA}$				
	Type B10	$I_{OH} = -10 \text{ mA}$				
	Type B12	$I_{OH} = -12 \text{ mA}$				
V_{OL}	Low level output voltage					V
	Type B4 to B12	$I_{OL} = 1 \mu A$			0.05	
	Type B4	$I_{OL} = 4 \text{ mA}$			0.4	
	Type B6	$I_{OL} = 6 \text{ mA}$				
	Type B8	$I_{OL} = 8 \text{ mA}$				
	Type B10	$I_{OL} = 10 \text{ mA}$				
	Type B12	$I_{OL} = 12 \text{ mA}$				

NOTES:

1. Type B6 means 6mA output driver cell.
2. Type B8 means 8mA output driver cell.

Normal I/O PAD DC Electrical Characteristics for Memory ($V_{DDMOP}=3.0V\pm 0.3V, 3.3V\pm 0.3V, T_A=-40$ to $85\text{ }^\circ\text{C}$)

Symbol	Parameters	Condition	Min	Typ.	Max	Unit
V_{IH}	High level input voltage					V
	LVC MOS interface		2.0			
V_{IL}	Low level input voltage					V
	LVC MOS interface				0.8	
V_T	Switching threshold			$0.5V_{DD}$		V
V_{T+}	Schmitt trigger, positive-going threshold	CMOS			2.0	V
V_{T-}	Schmitt trigger, negative-going threshold	CMOS	0.8			V
I_{IH}	High level input current					μA
	Input buffer	$V_{IN} = V_{DD}$	-10		10	
I_{IL}	Low level input current					μA
	Input buffer	$V_{IN} = V_{SS}$	-10		10	
	Input buffer with pull-up		-60	-33	-10	
V_{OH}	High level output voltage					V
	Type B4 to B12	$I_{OH} = -1\text{ }\mu\text{A}$	$V_{DD} - 0.05$			
	Type B4	$I_{OH} = -4\text{ mA}$	2.4			
	Type B6	$I_{OH} = -6\text{ mA}$				
	Type B8	$I_{OH} = -8\text{ mA}$				
	Type B10	$I_{OH} = -10\text{ mA}$				
	Type B12	$I_{OH} = -12\text{ mA}$				
V_{OL}	Low level output voltage					V
	Type B4 to B12	$I_{OL} = 1\text{ }\mu\text{A}$			0.05	
	Type B4	$I_{OL} = 4\text{ mA}$			0.4	
	Type B6	$I_{OL} = 6\text{ mA}$				
	Type B8	$I_{OL} = 8\text{ mA}$				
	Type B10	$I_{OL} = 10\text{ mA}$				
	Type B12	$I_{OL} = 12\text{ mA}$				

NOTES:

1. Type B6 means 6mA output driver cell.
2. Type B8 means 8mA output driver cell.
3. Type B12 means 12mA output driver cells.

Normal I/O PAD DC Electrical Characteristics for I/O ($V_{DDOP} = 3.3V \pm 0.3V$, $T_A = -40$ to 85 °C)

Symbol	Parameters	Condition	Min	Typ.	Max	Unit
V_{IH}	High level input voltage					V
	LVC MOS interface		2.0			
V_{IL}	Low level input voltage					V
	LVC MOS interface				0.8	
V_T	Switching threshold			$0.5V_{DD}$		V
V_{T+}	Schmitt trigger, positive-going threshold	CMOS			2.0	V
V_{T-}	Schmitt trigger, negative-going threshold	CMOS	0.8			V
I_{IH}	High level input current					μA
	Input buffer	$V_{IN} = V_{DD}$	-10		10	
I_{IL}	Low level input current					μA
	Input buffer	$V_{IN} = V_{SS}$	-10		10	
	Input buffer with pull-up		-60	-33	-10	
V_{OH}	High level output voltage					V
	Type B4 to B12	$I_{OH} = -1 \mu A$	$V_{DD} - 0.05$			
	Type B4	$I_{OH} = -4 \text{ mA}$	2.4			
	Type B6	$I_{OH} = -6 \text{ mA}$				
	Type B8	$I_{OH} = -8 \text{ mA}$				
	Type B10	$I_{OH} = -10 \text{ mA}$				
	Type B12	$I_{OH} = -12 \text{ mA}$				
V_{OL}	Low level output voltage					V
	Type B4 to B12	$I_{OL} = 1 \mu A$			0.05	
	Type B4	$I_{OL} = 4 \text{ mA}$			0.4	
	Type B6	$I_{OL} = 6 \text{ mA}$				
	Type B8	$I_{OL} = 8 \text{ mA}$				
	Type B10	$I_{OL} = 10 \text{ mA}$				
	Type B12	$I_{OL} = 12 \text{ mA}$				

NOTES:

1. Type B6 means 6mA output driver cell.
2. Type B8 means 8mA output driver cell.
3. Type B12 means 12mA output driver cells.

Table 27-4. USB DC Electrical Characteristics

Symbol	Parameter	Condition	Min	Max	Unit
V_{IH}	High level input voltage	–	2.5	–	V
V_{IL}	Low level input voltage	–	–	0.8	V
I_{IH}	High level input current	$V_{in} = 3.3V$	–10	10	μA
I_{IL}	Low level input current	$V_{in} = 0.0V$	–10	10	μA
V_{OH}	Static output high	15K to GND	2.8	3.6	V
V_{OL}	Static output low	1.5K to 3.6V		0.3	V

Table 27-5. S3C2440 Power Supply Voltage and Current

Parameter	Value	Unit	Condition
Typical V_{DDi} / V_{DDOP}	1.3 / 3.3	V	Without DVS
Max. Operating frequency (FCLK)	400	MHz	–
Max. Operating frequency (HCLK)	133	MHz	–
Max. Operating frequency (PCLK)	67	MHz	–
Typical normal mode power ⁽³⁾ (Total $V_{DDi} + V_{IO}$)	368	mW	(1)
Typical normal mode power ⁽³⁾ (Total $V_{DDi} + V_{IO}$)	310	mW	(2)
Typical idle mode power ⁽³⁾ (Total $V_{DDi} + V_{IO}$)	213	mW	FCLK = 400MHz (F:H:P = 1:3:6)
Typical slow mode power ⁽³⁾ (Total $V_{DDi} + V_{IO}$)	97	mW	FCLK = 12MHz (F:H:P = 1:1:1)
Typical Sleep mode power ⁽³⁾	380	μA	@1.2/3.3V, Room temperature All other I/O static.
Typical RTC power ⁽³⁾	3	μA	@3.0V, Room temperature X-tal = 32.768kHz for RTC

NOTES:

- I/D cache: ON, MMU: ON, Code on SRAM, FCLK:HCLK:PCLK = 400MHz:133MHz:66.7MHz
:LCD ON (320x240x16bppx60Hz, color TFT):13 kHz Timer internal mode (5 Channel run)
:Audio (IIS&DMA, CDCLK=16.9MHz, LRCK=44.1kHz):Integer data quick sort (65536 EA)
- Pocket PC 2003 MPEG play
- The above power consumption data is measured in Room temperature with random sample (Lot #: KZZ1FS).

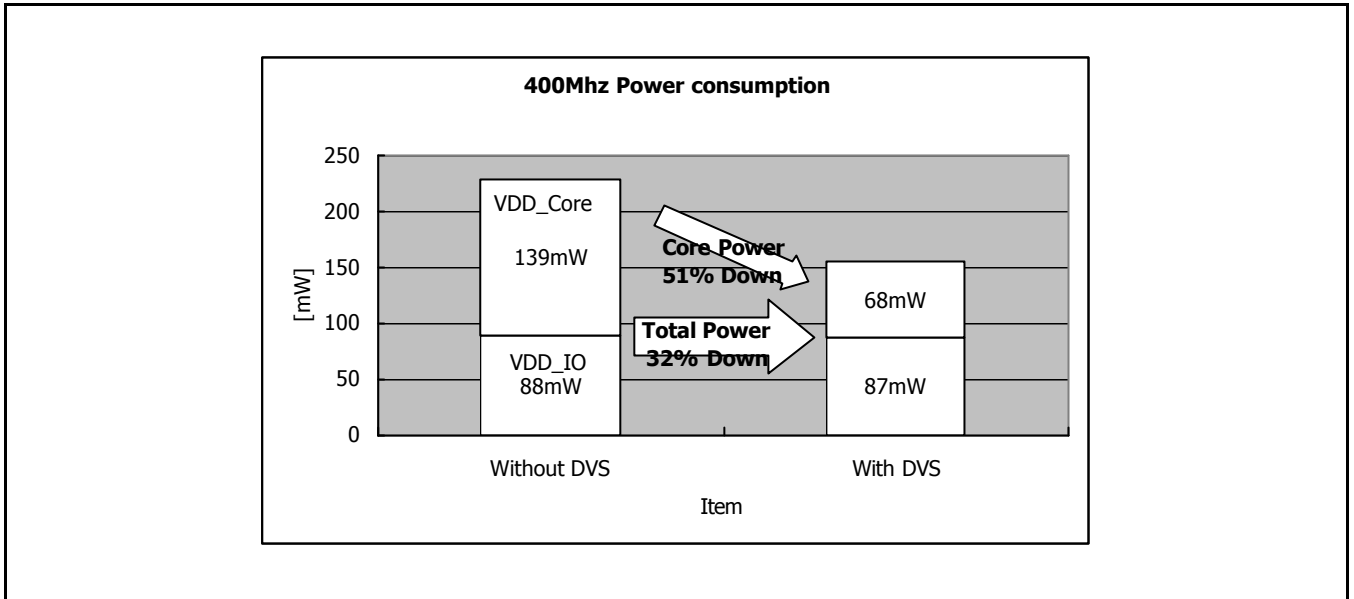

Figure 27-1. Power Consumption Example Comparison when Applied DVS Scheme

NOTE: (Condition) Current measure condition: Play Battlife.wma(bit rate=64kbps) on PPC2003 SMDK2440.
 Core power:
 Without DVS : VDDiarm/VDDi/VDDupll/VDDmpll/VDDalive = 1.3V
 using DVS : VDDiarm/VDDi = 1.3V ⇔ 1.0V, VDDupll/VDDmpll/VDDalive = 1.3V
 I/O Power : VDDOP/VDDMOP/VDDRRTC/VDDADC=3.3V
 Refer the Application notes for more information about DVS.

Table 27-6. Typical Current Decrease by CLKCON Register

FCLK:HCLK:PCLK = 300:100:50MHz, 1.2V (Random sample)

(Unit: mA)

Peripherals	NFC	LCD	USBH	USBD	Timer	SDI	UART	RTC	ADC	IIC	IIS	SPI	Camera	Total
Current	1.7	2.8	0.37	0.79	0.32	1.0	2.7	0.45	0.26	0.32	0.78	0.16	14.25	26.26

NOTE: This table includes power consumption of each peripheral. For example, If you do not use Camera and have turned off the Camera block by CLKCON register, then you can save the 14.25mA of internal block.

A.C. ELECTRICAL CHARACTERISTICS

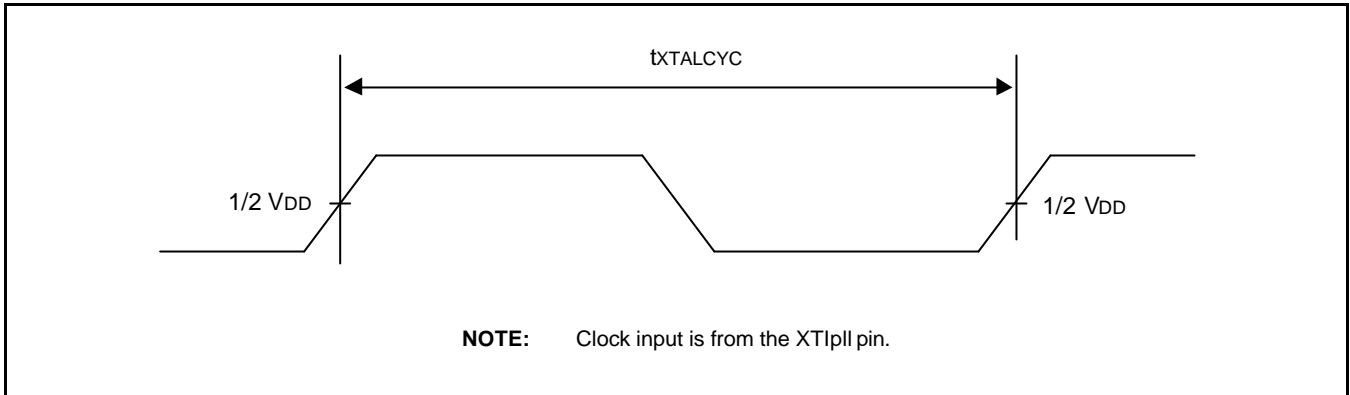

Figure 27-2. XTlpll Clock Timing Diagram

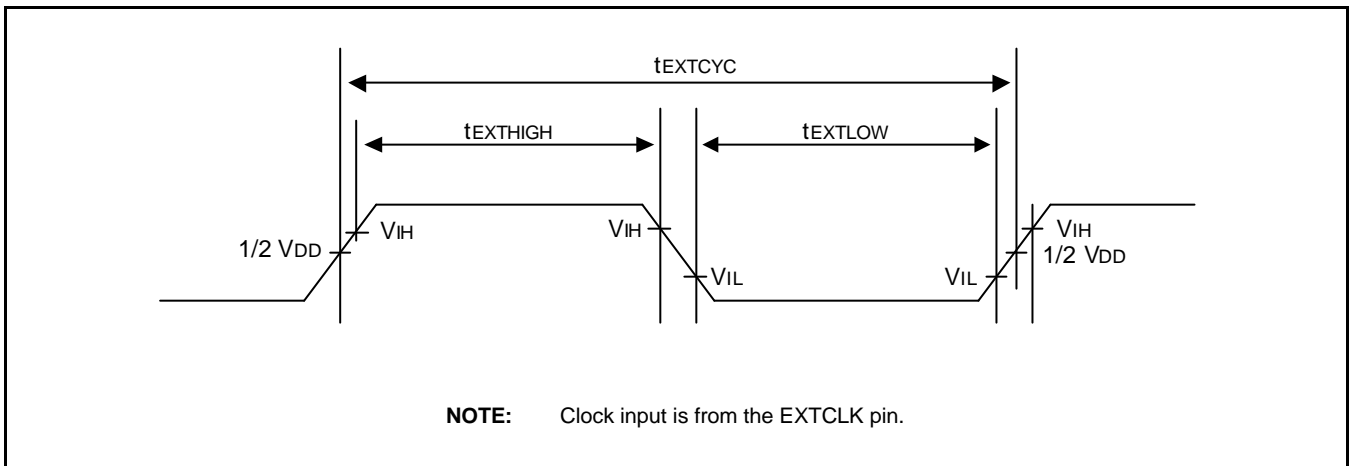

Figure 27-3. EXTCLK Clock Input Timing Diagram

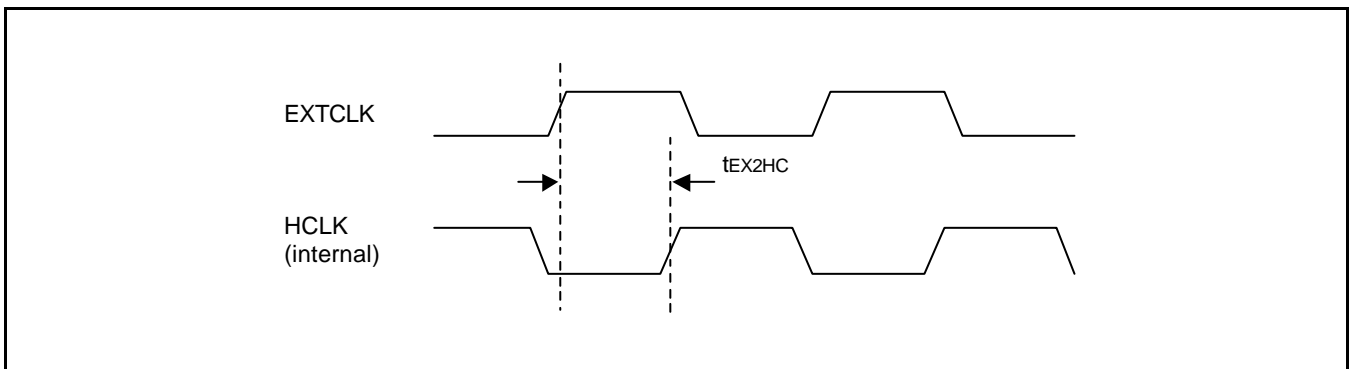

Figure 27-4. EXTCLK/HCLK in case when EXTCLK is used Without the PLL

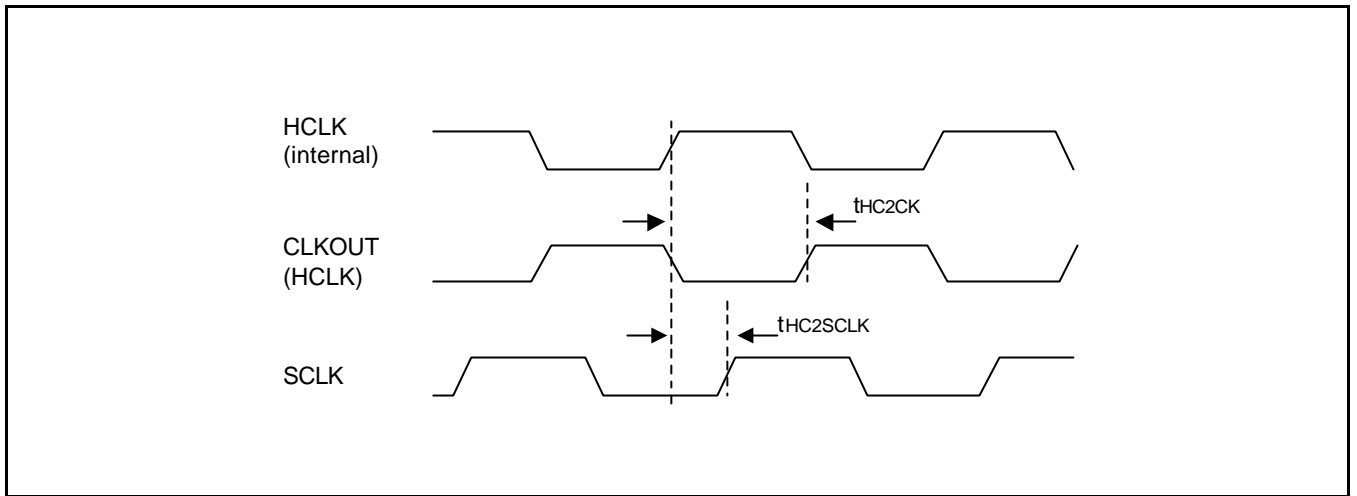

Figure 27-5. HCLK/CLKOUT/SCLK in case when EXTCLK is used

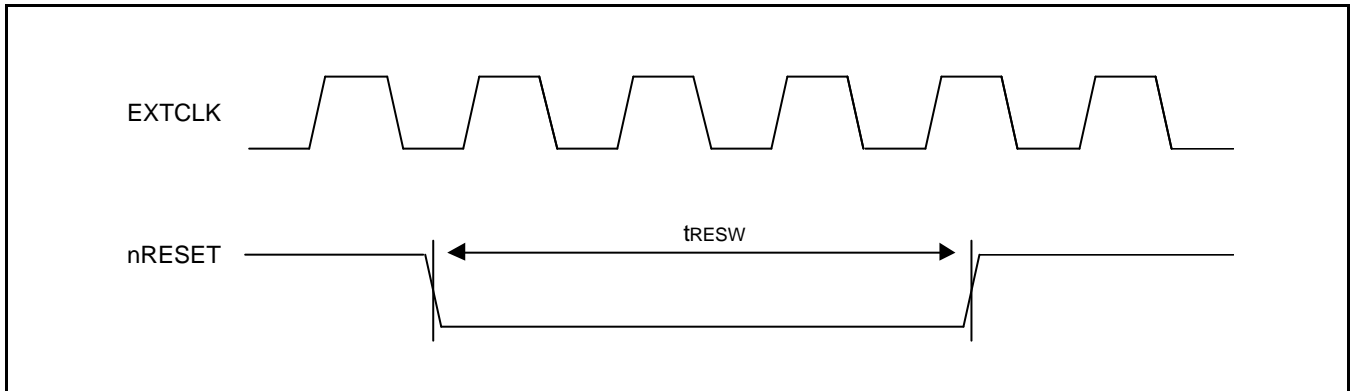

Figure 27-6. Manual Reset Input Timing Diagram

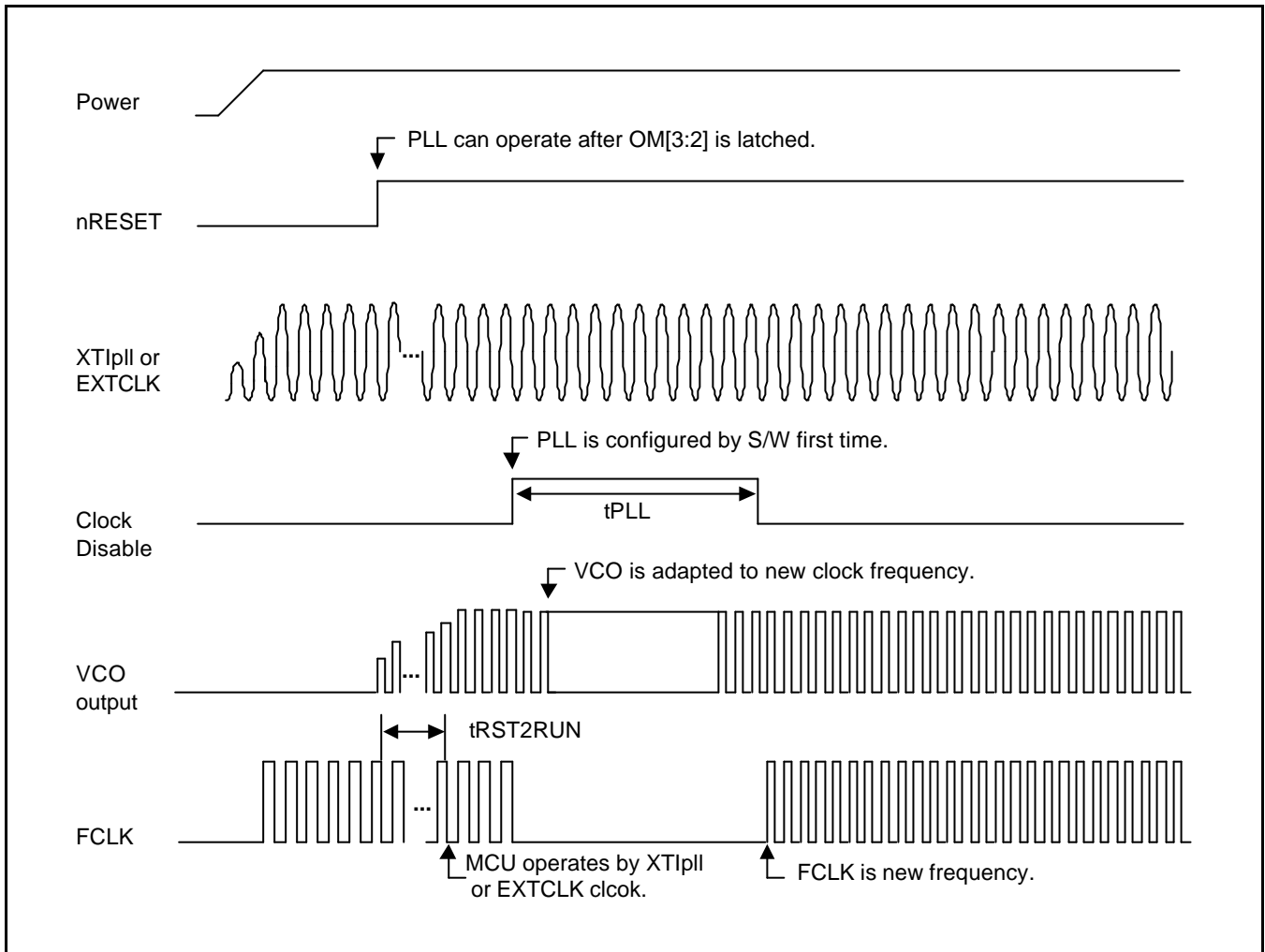

Figure 27-7. Power-On Oscillation Setting Timing Diagram

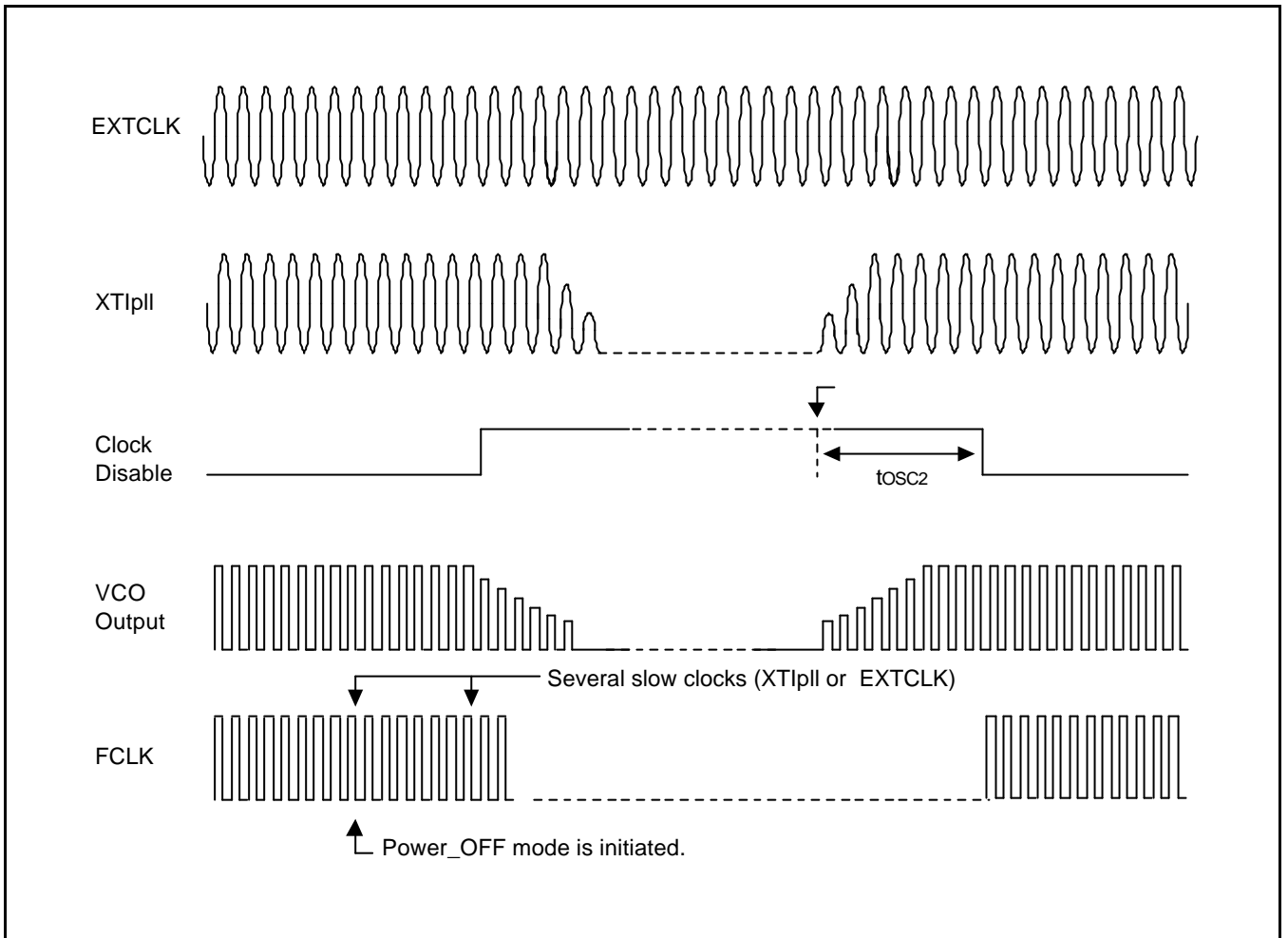

Figure 27-8. Sleep Mode Return Oscillation Setting Timing Diagram

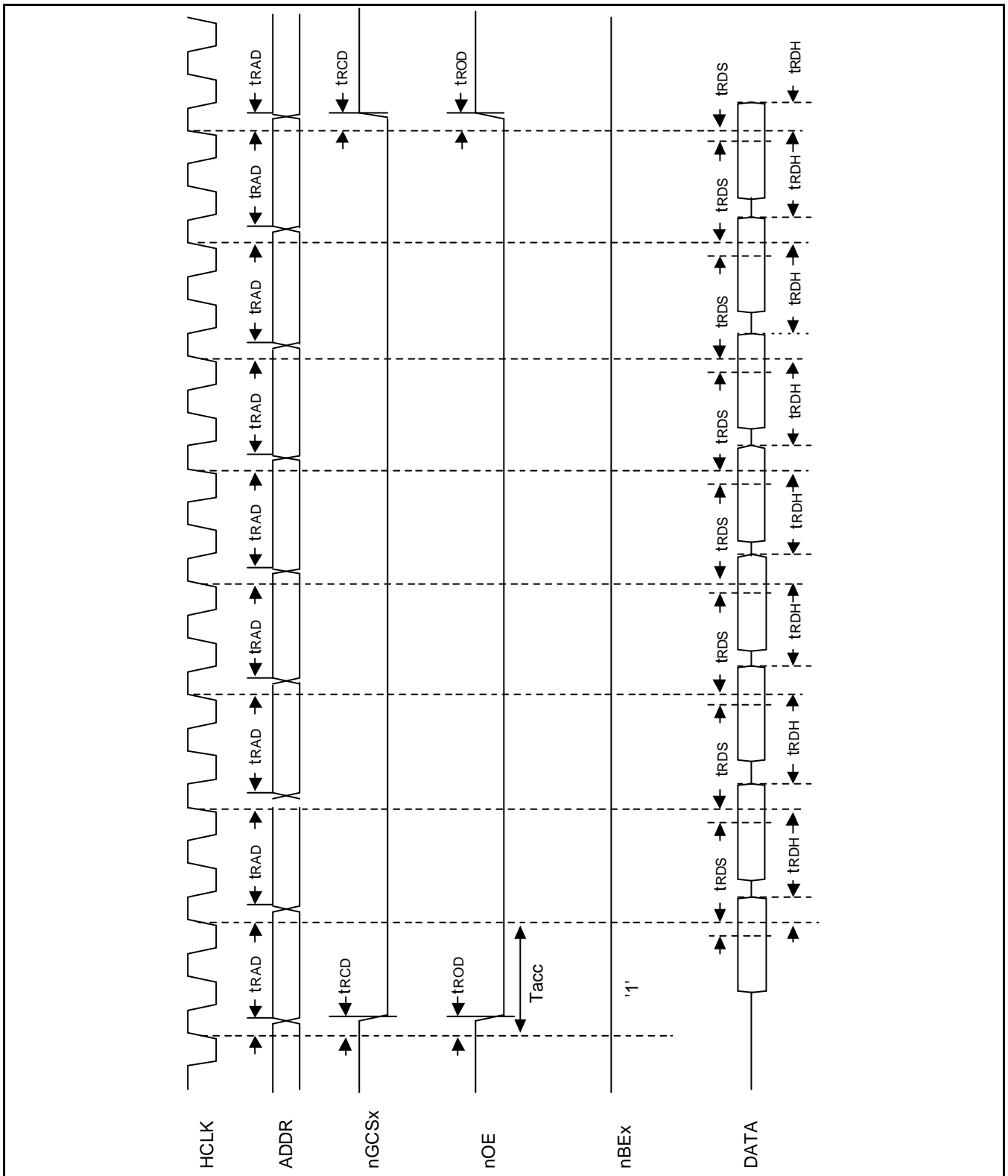

Figure 27-9. ROM/SRAM Burst READ Timing Diagram (I)
 (Tacs=0, Tcos=0, Tacc=2, Toch=0, Tcah=0, PMC=0, ST=0, DW=16bit)

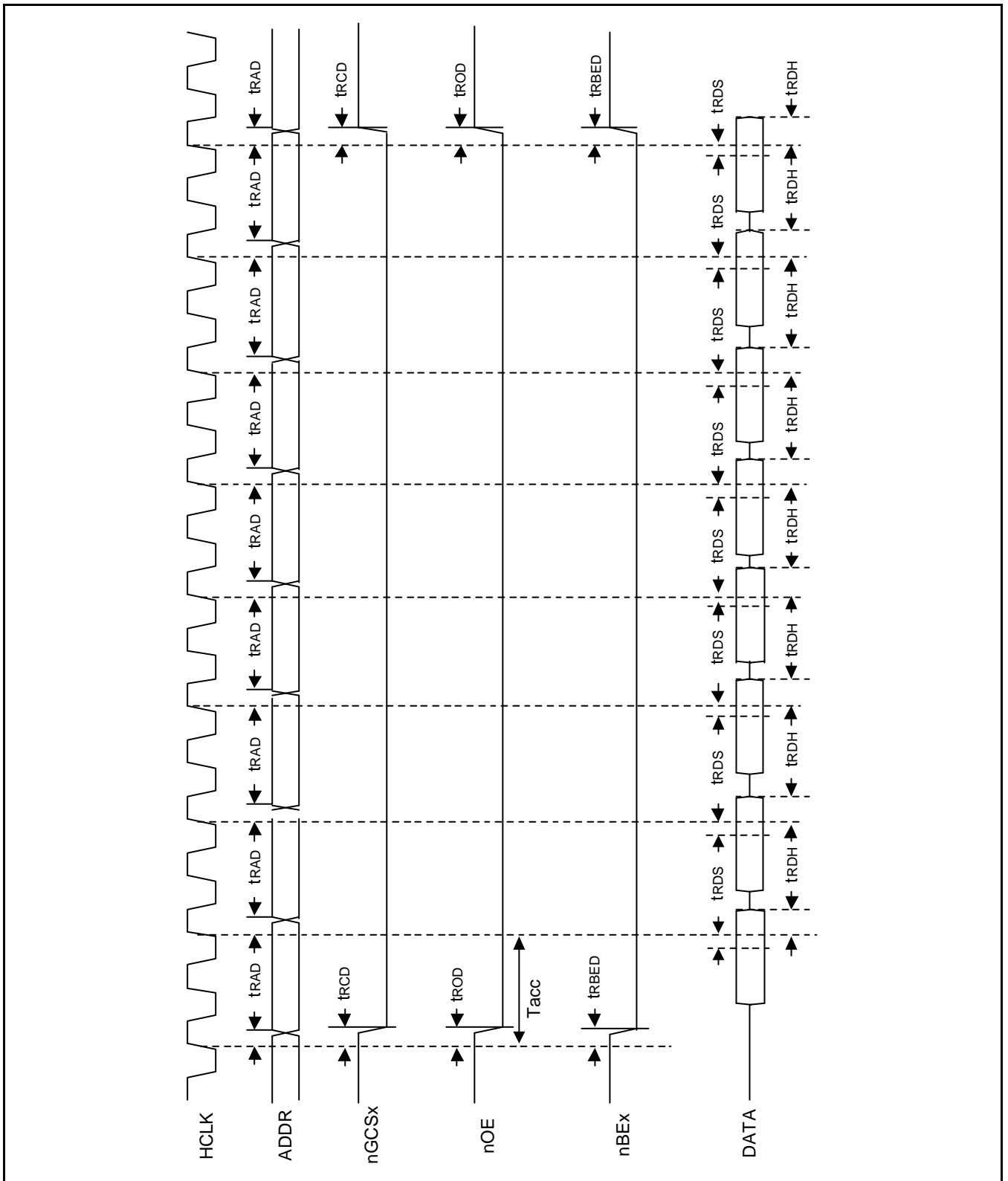

Figure 27-10. ROM/SRAM Burst READ Timing Diagram (II)
 (Tacs=0, Tcos=0, Tacc=2, Toch=0, Tcah=0, PMC=0, ST=1, DW=16bit)

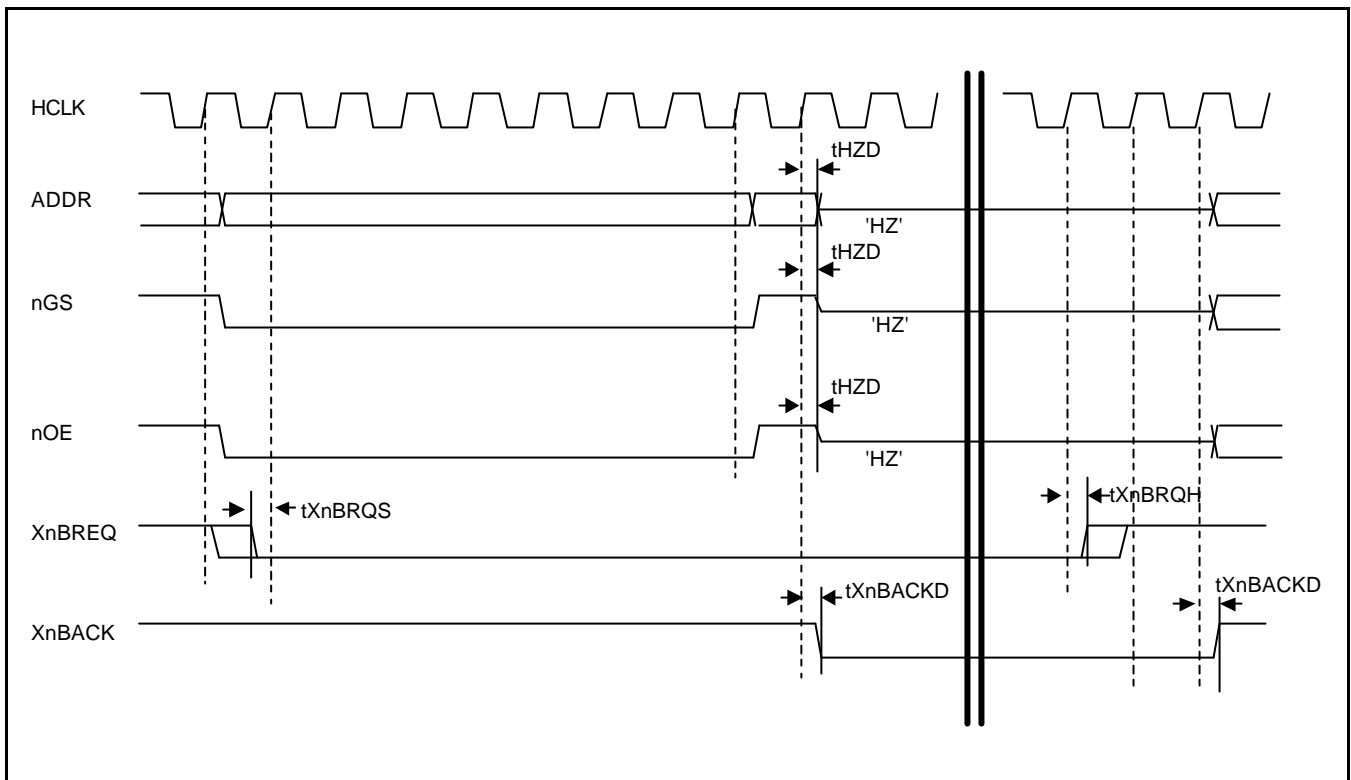

Figure 27-11. External Bus Request in ROM/SRAM Cycle
($T_{acs}=0$, $T_{cos}=0$, $T_{acc}=8$, $T_{och}=0$, $T_{cah}=0$, $PMC=0$, $ST=0$)

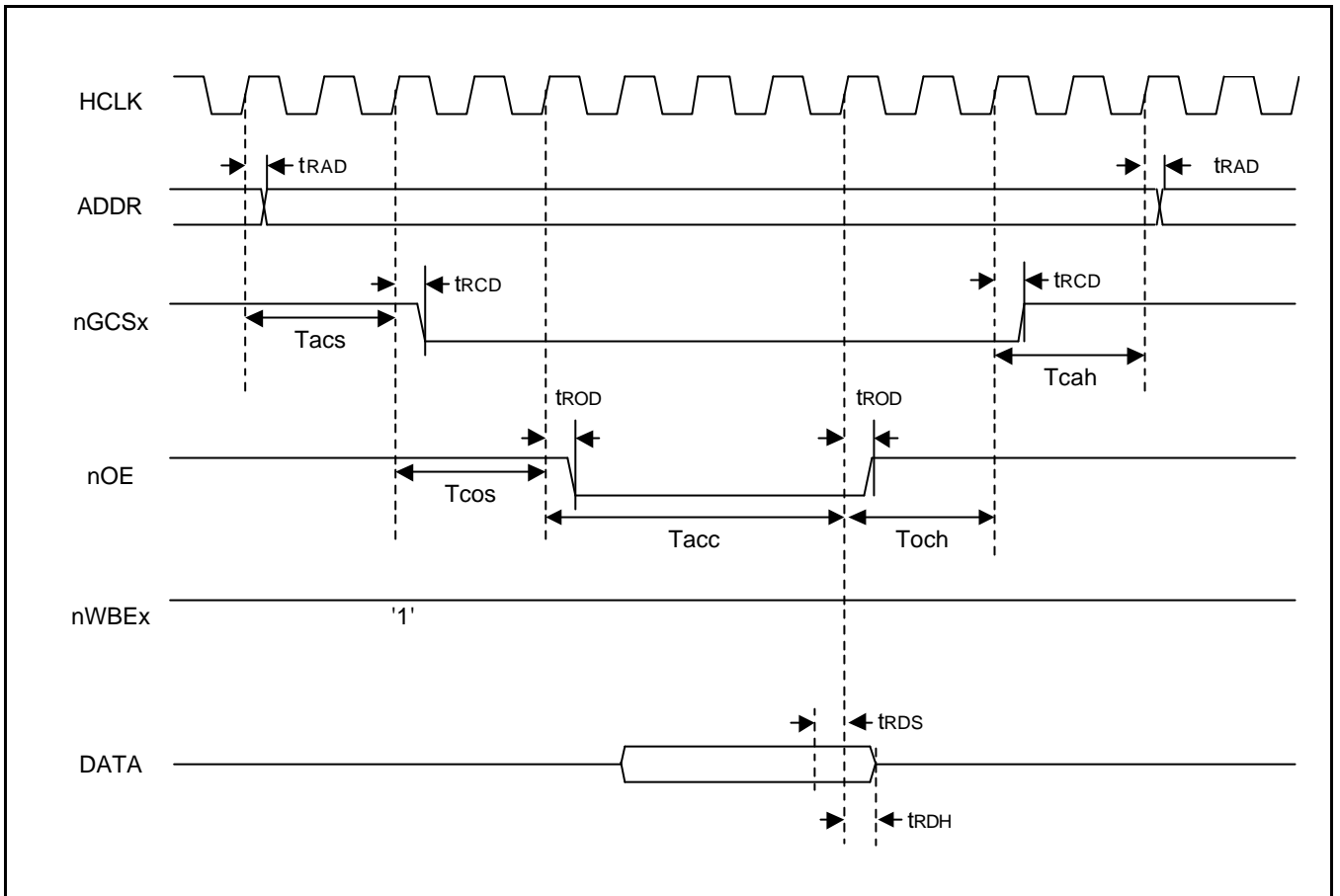

Figure 27-12. ROM/SRAM READ Timing Diagram (I)
 ($T_{acs}=2$, $T_{cos}=2$, $T_{acc}=4$, $T_{och}=2$, $T_{cah}=2$, $PMC=0$, $ST=0$)

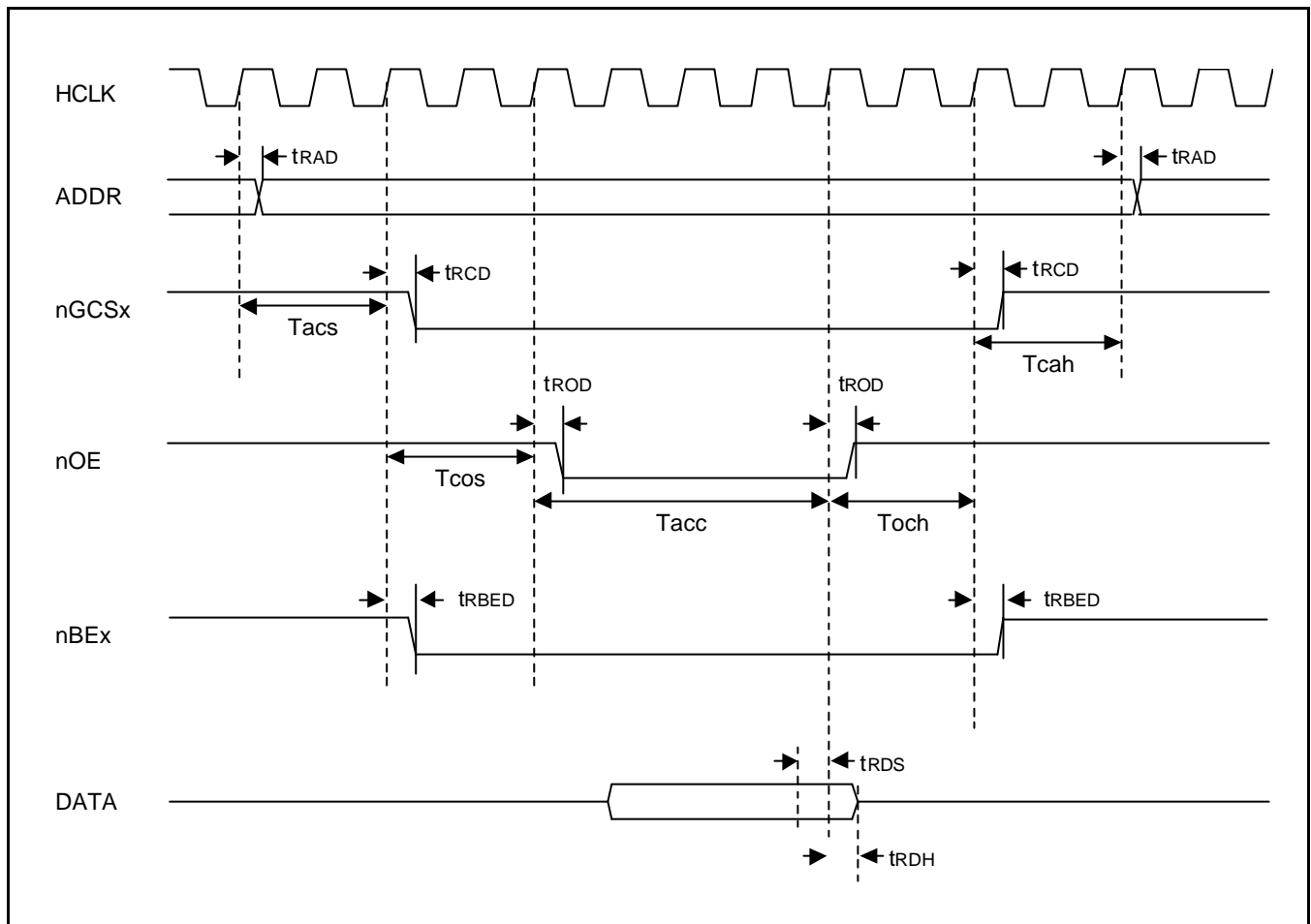

Figure 27-13. ROM/SRAM READ Timing Diagram (II)
 (Tacs=2, Tcos=2, Tacc=4, Toch=2, Tcah=2cycle, PMC=0, ST=1)

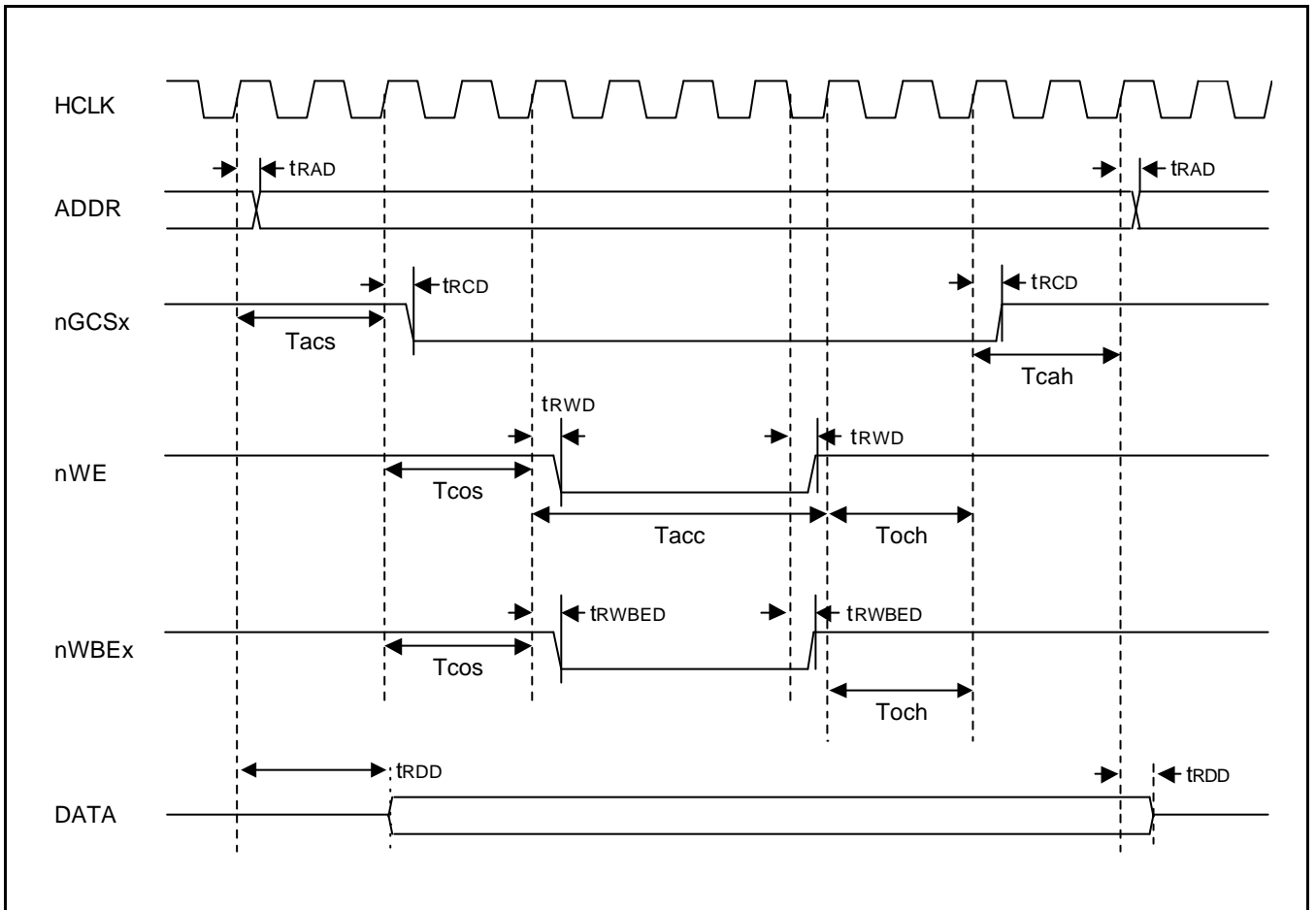

Figure 27-14. ROM/SRAM WRITE Timing Diagram (I)
 (Tacs=2, Tcos=2, Tacc=4, Toch=2, Tcah=2, PMC=0, ST=0)

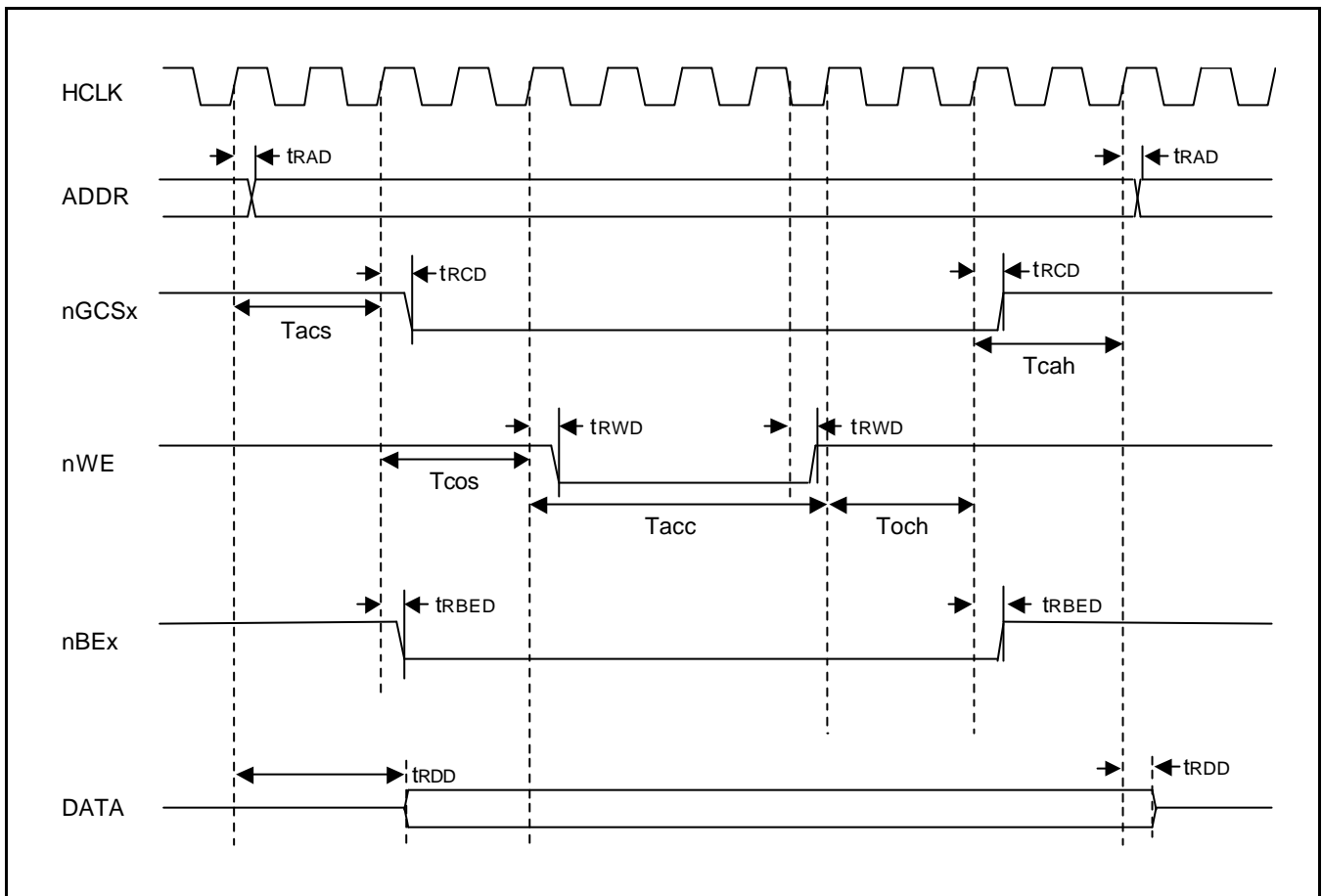

Figure 27-15. ROM/SRAM WRITE Timing Diagram (II)
 (Tacs=2, Tcos=2, Tacc=4, Toch=2, Tcah=2, PMC=0, ST=1)

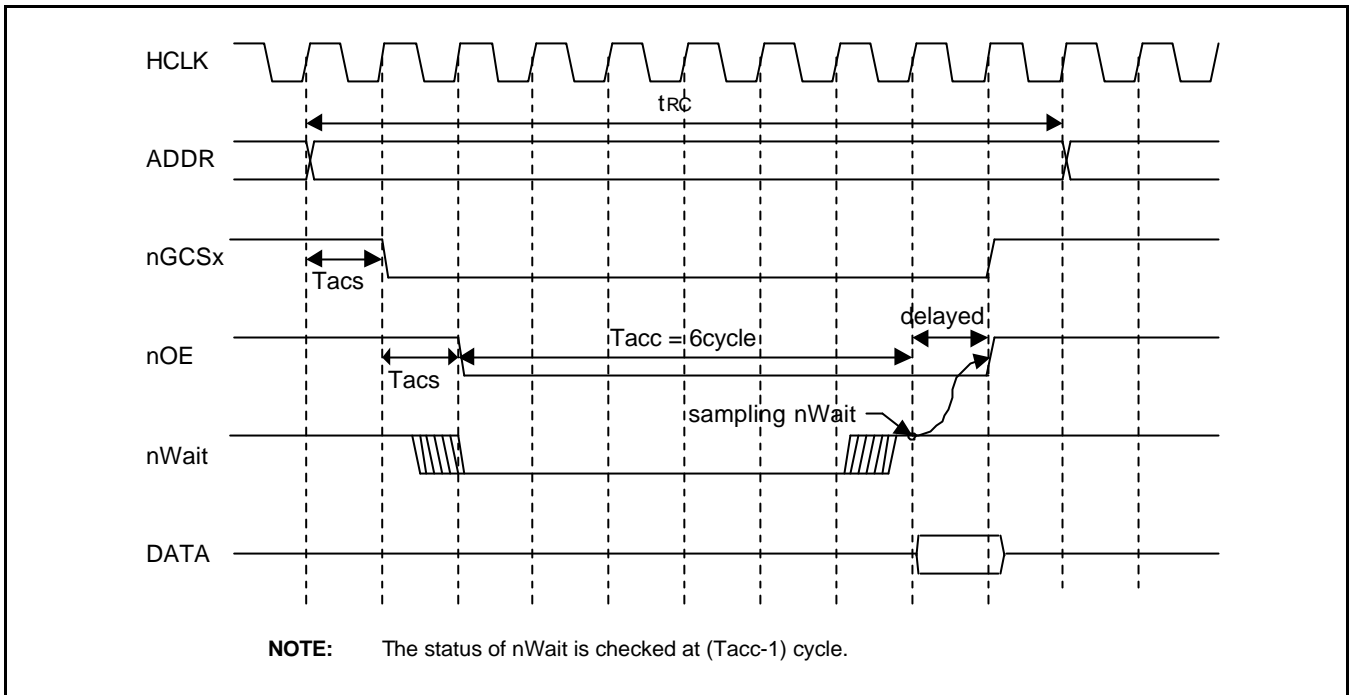

Figure 27-16. External nWAIT READ Timing Diagram
 (Tacs=0, Tcos=0, Tacc=6, Toch=0, Tcah=0, PMC=0, ST=0)

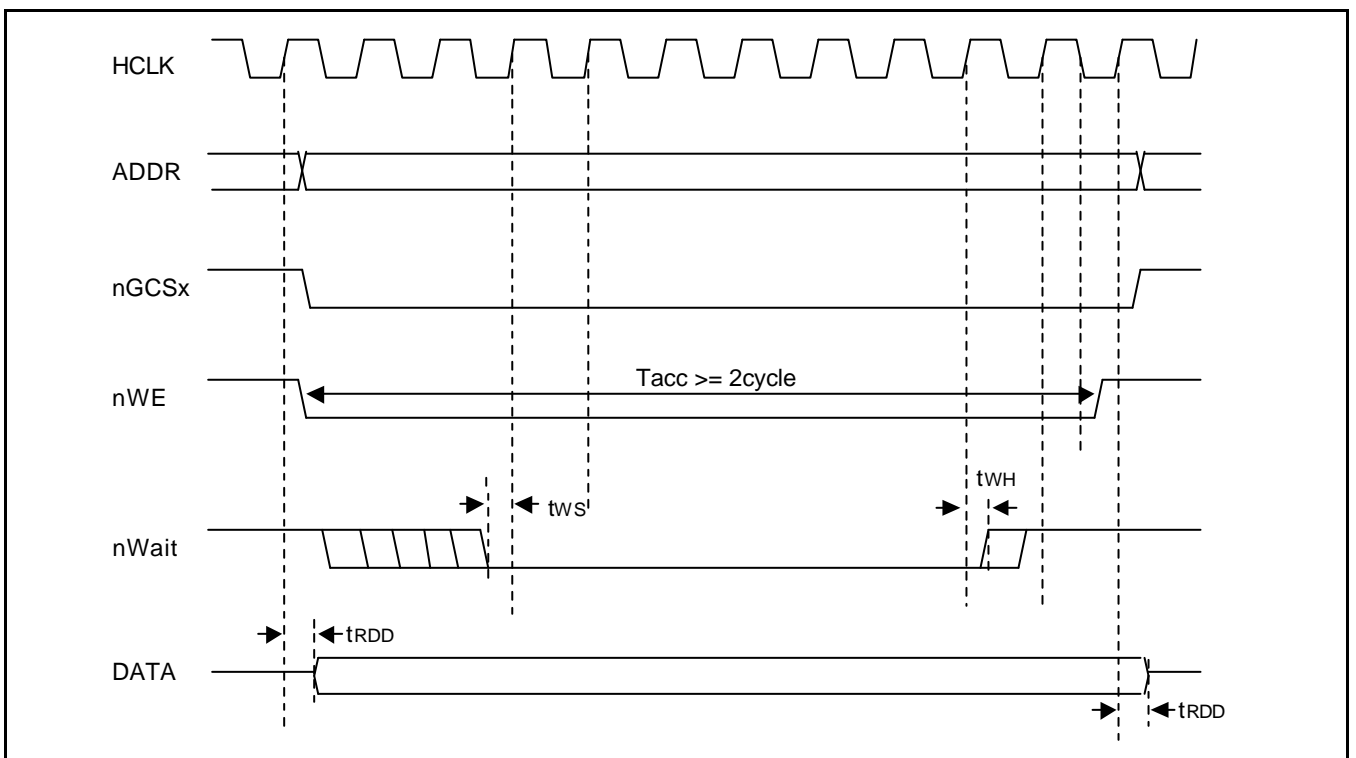

Figure 27-17. External nWAIT WRITE Timing Diagram
 (Tacs=0, Tcos=0, Tacc=4, Toch=0, Tcah=0, PMC=0, ST=0)

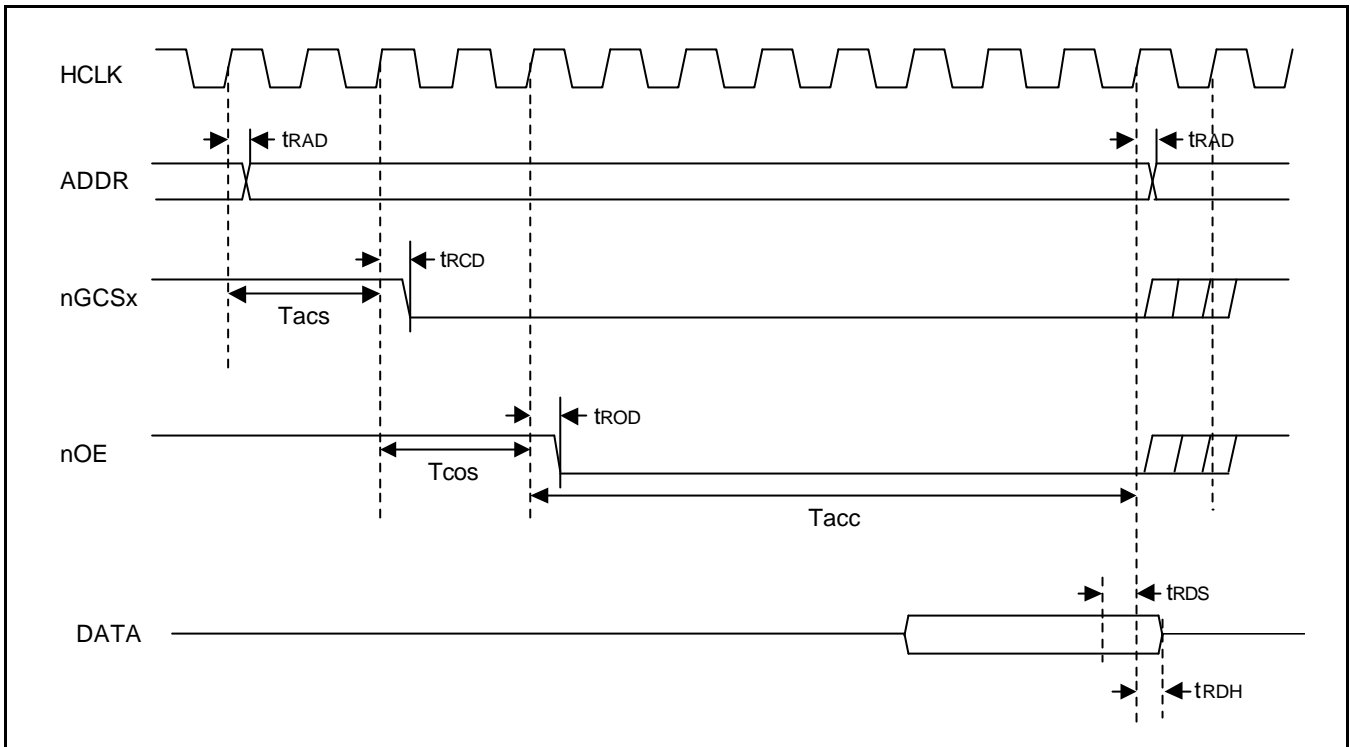

Figure 27-18. Masked-ROM Single READ Timing Diagram ($T_{acs}=2$, $T_{cos}=2$, $T_{acc}=8$, $PMC=01/10/11$)

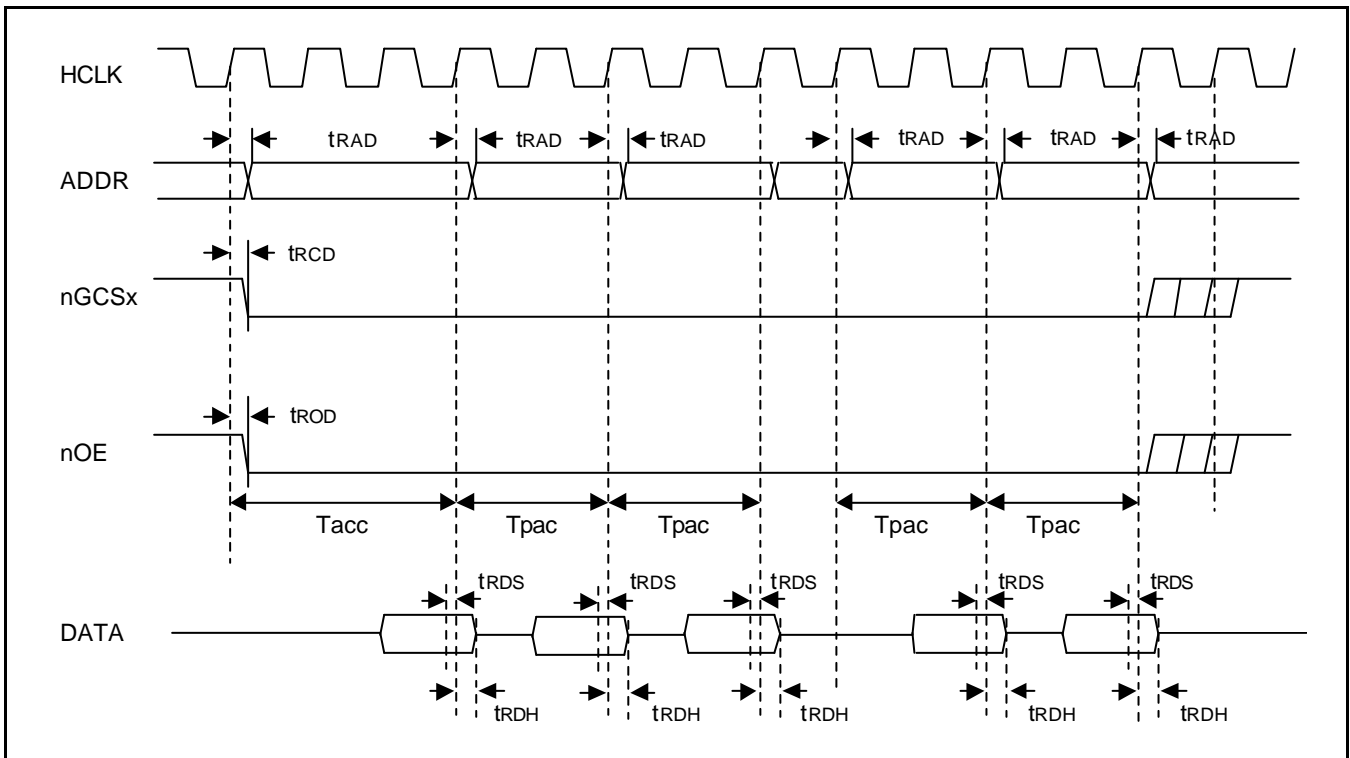

Figure 27-19. Masked-ROM Consecutive READ Timing Diagram ($T_{acs}=0$, $T_{cos}=0$, $T_{acc}=3$, $T_{pac}=2$, $PMC=01/10/11$)

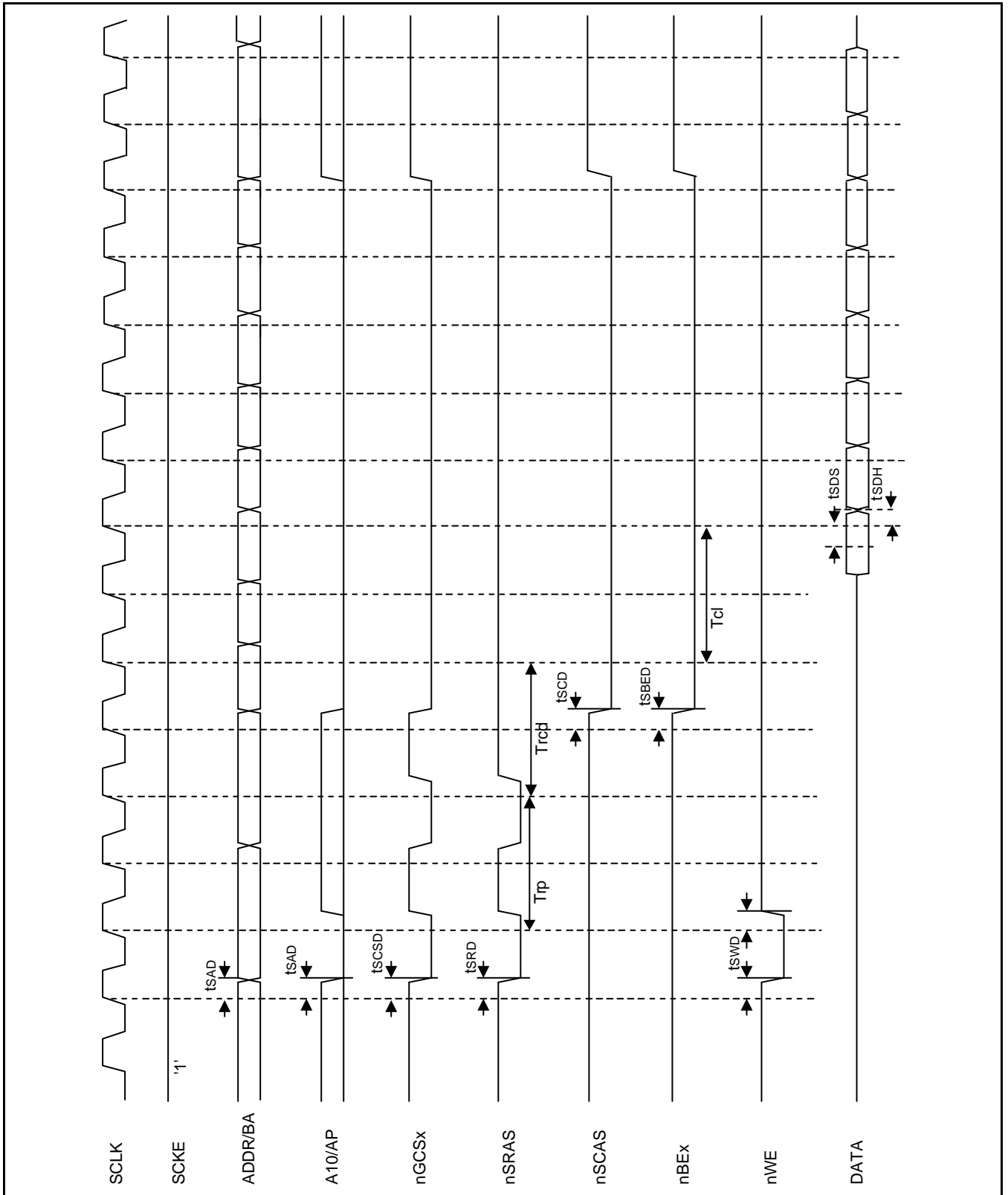

Figure 27-20. SDRAM Single Burst READ Timing Diagram ($T_{rp}=2$, $T_{rcd}=2$, $T_{cI}=2$, $DW=16$ bit)

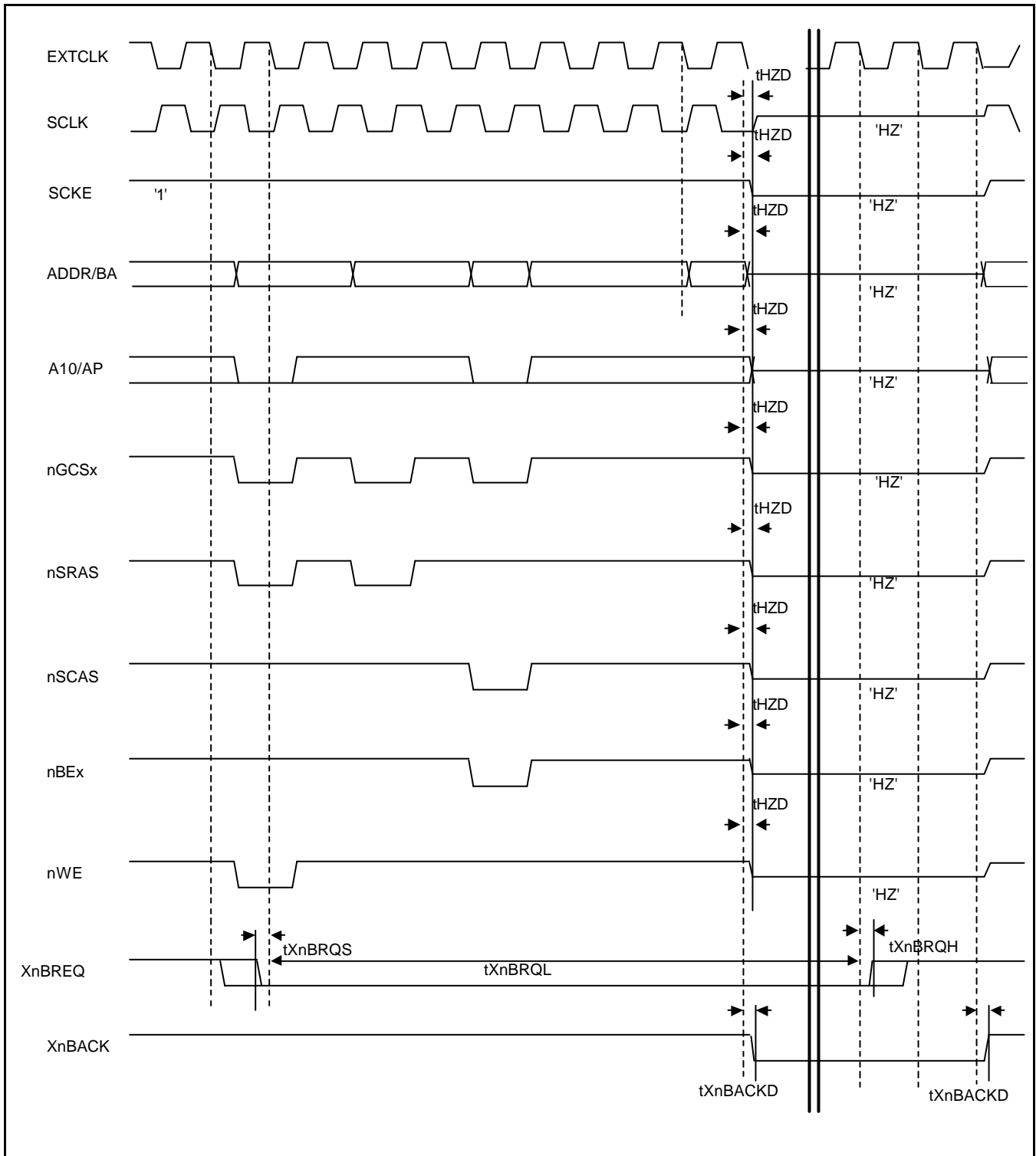

Figure 27-21. External Bus Request in SDRAM Timing Diagram (Trp=2, Trcd=2, Tcl=2)

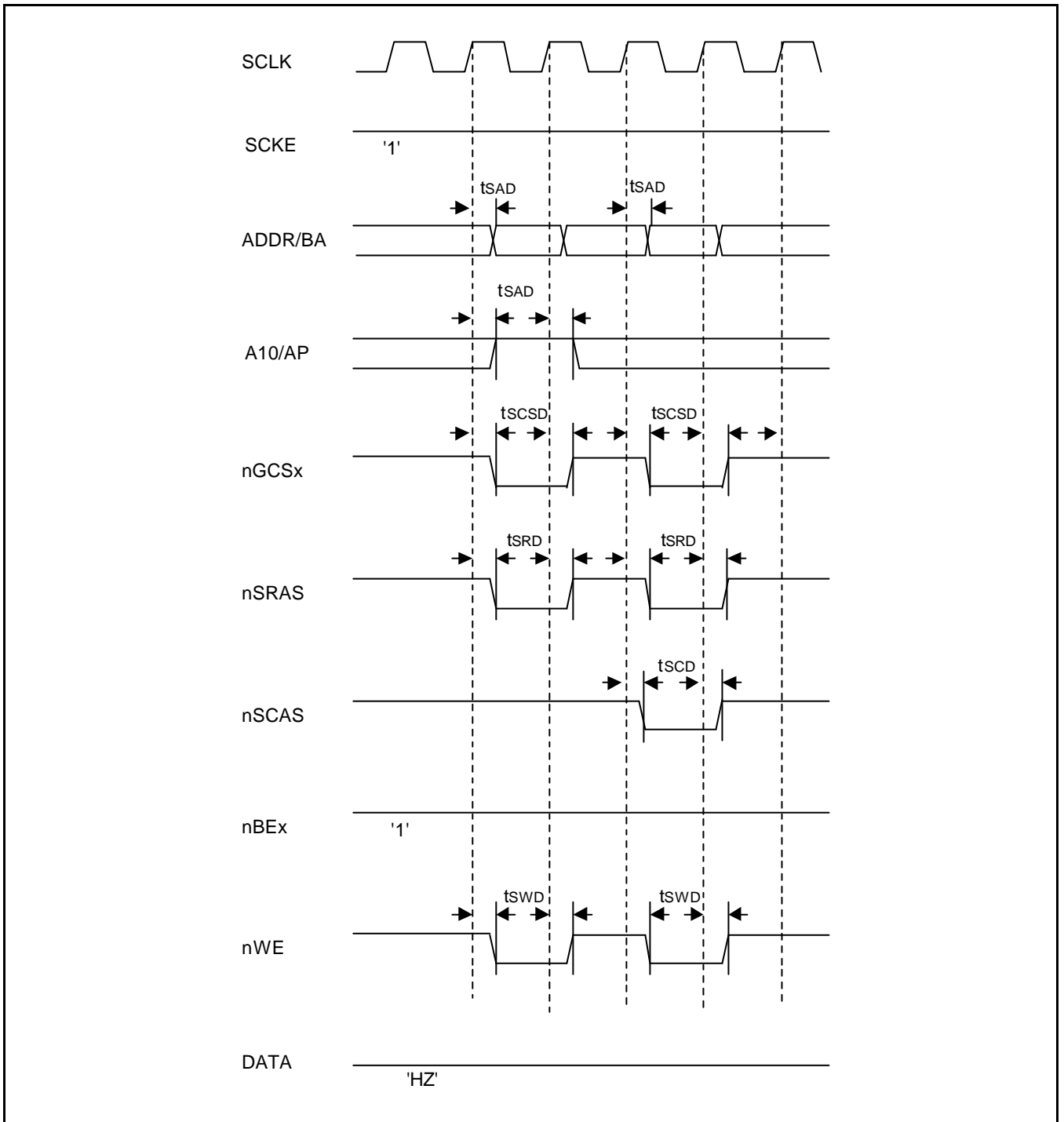

Figure 27-22. SDRAM MRS Timing Diagram

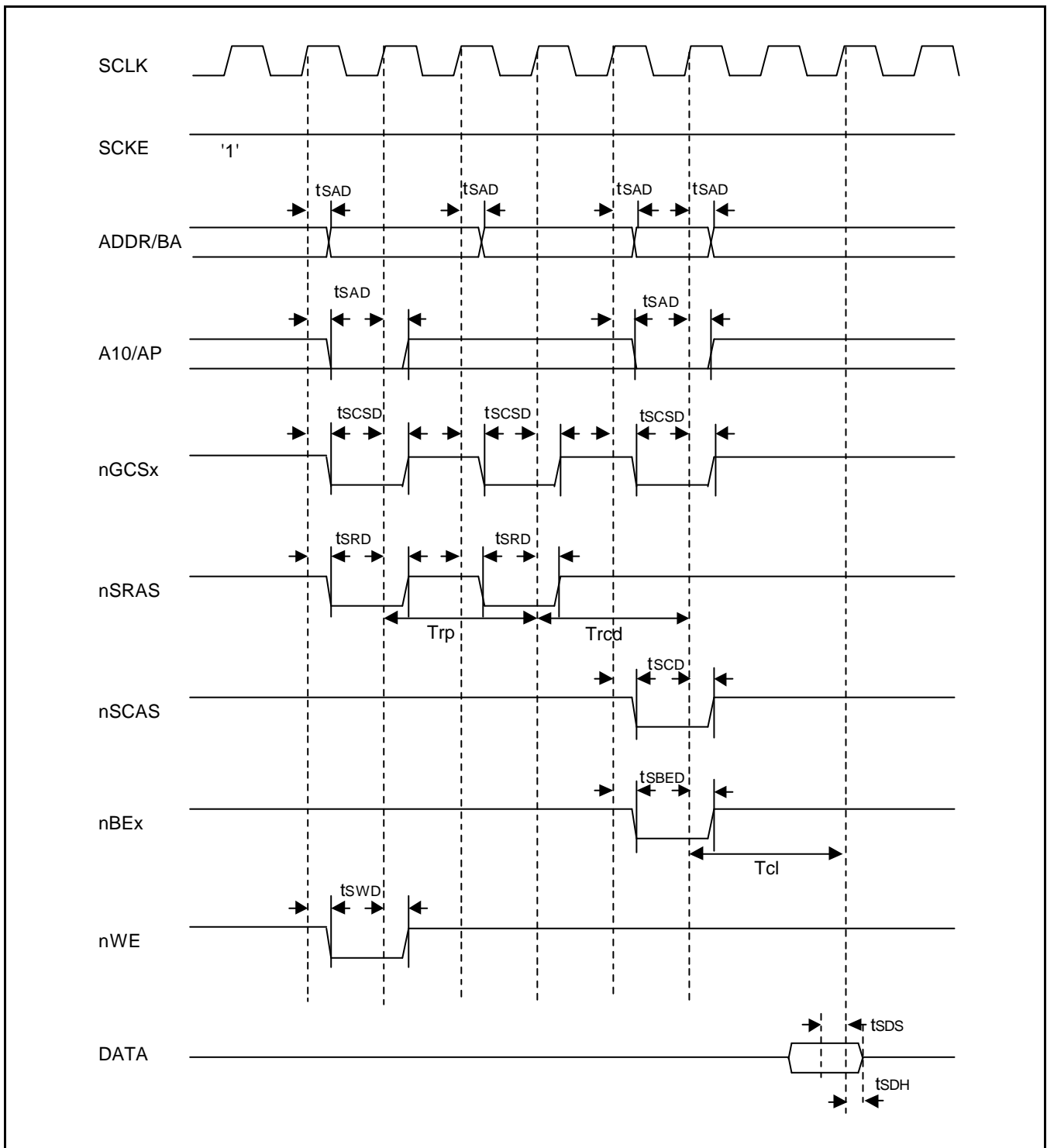

Figure 27-23. SDRAM Single READ Timing Diagram (I) ($Trp=2$, $Trcd=2$, $T_{cl}=2$)

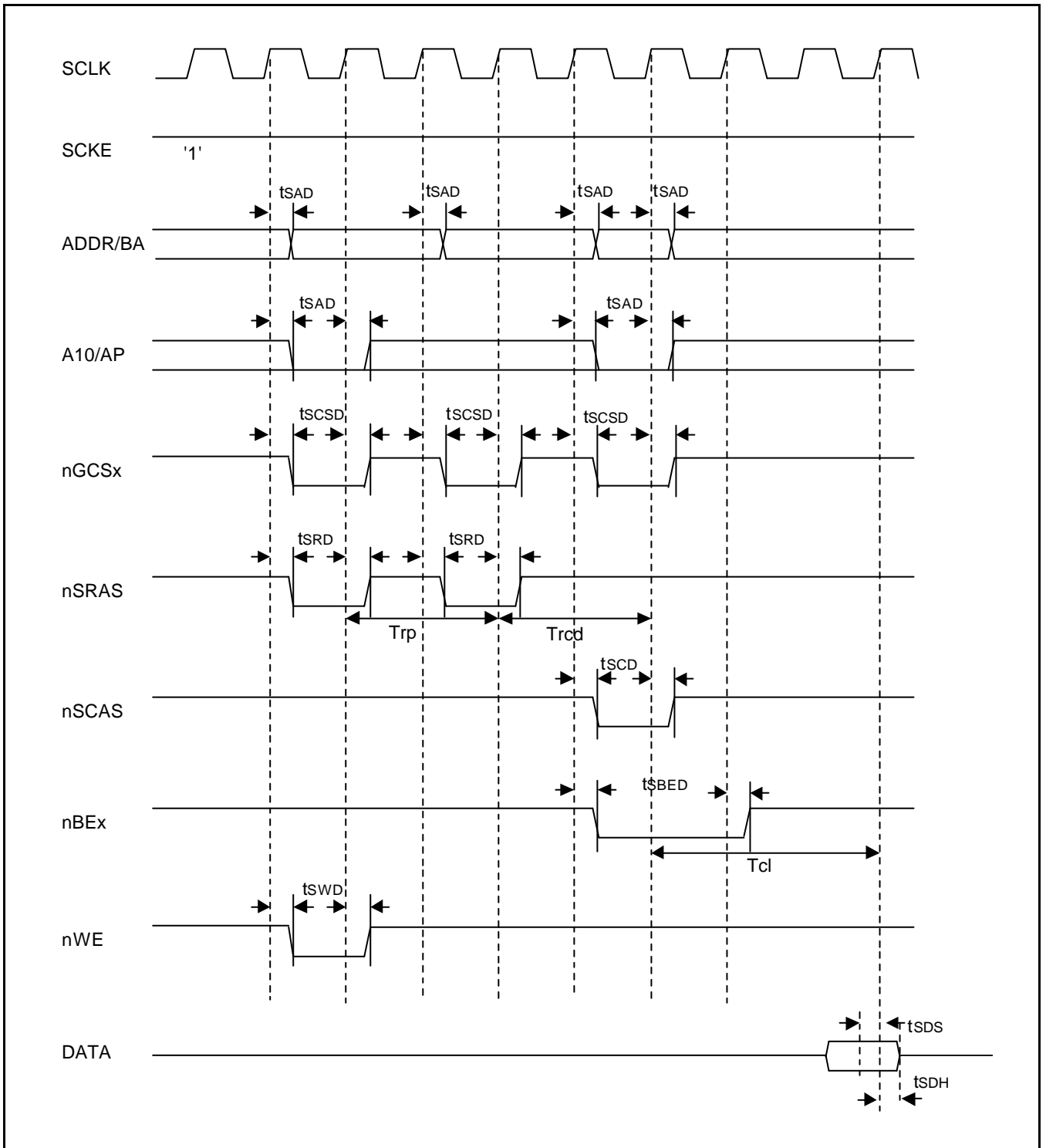

Figure 27-24. SDRAM Single READ Timing Diagram (II) ($Trp=2$, $Trcd=2$, $Tcl=3$)

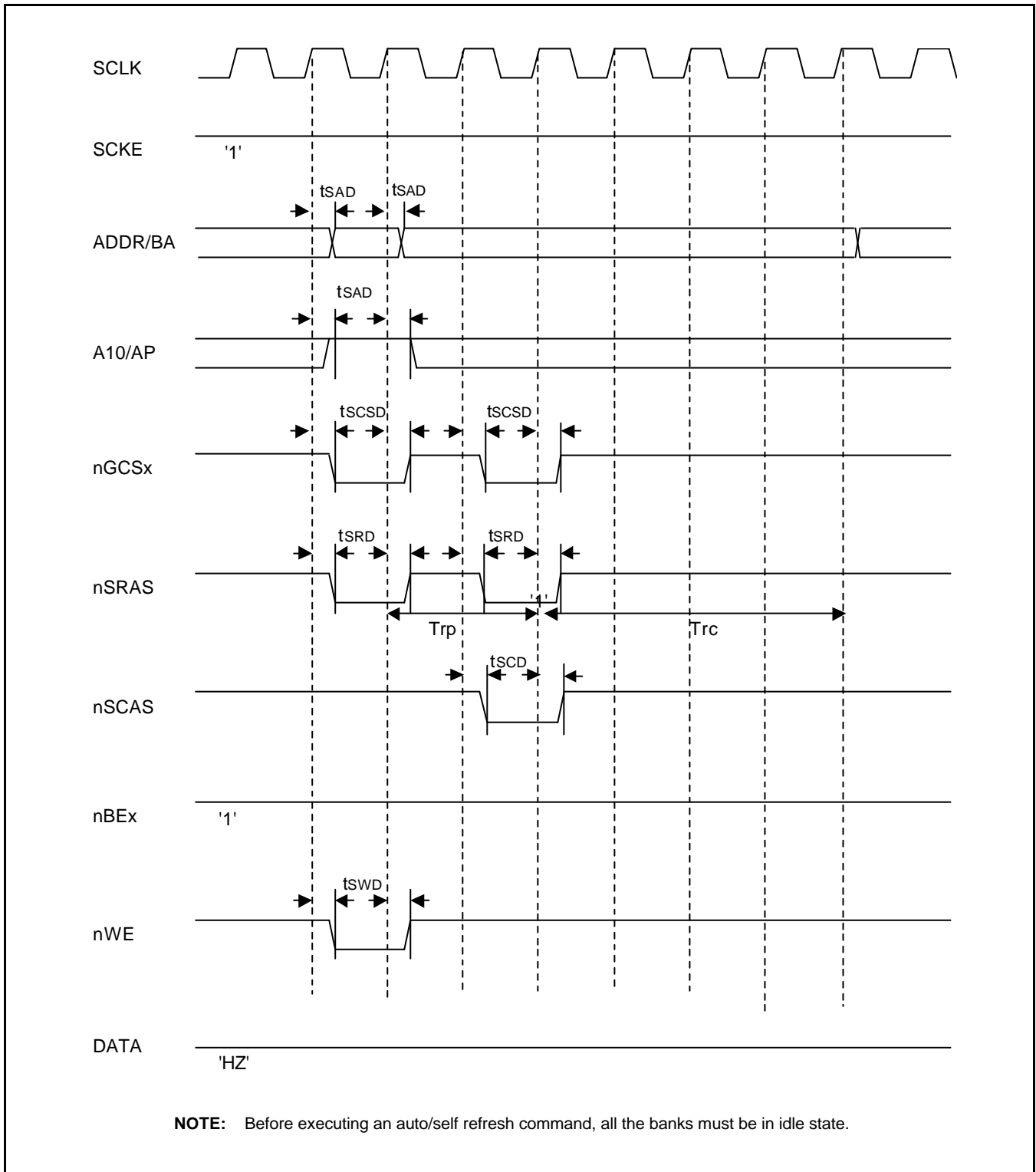

Figure 27-25. SDRAM Auto Refresh Timing Diagram ($Trp=2, Trc=4$)

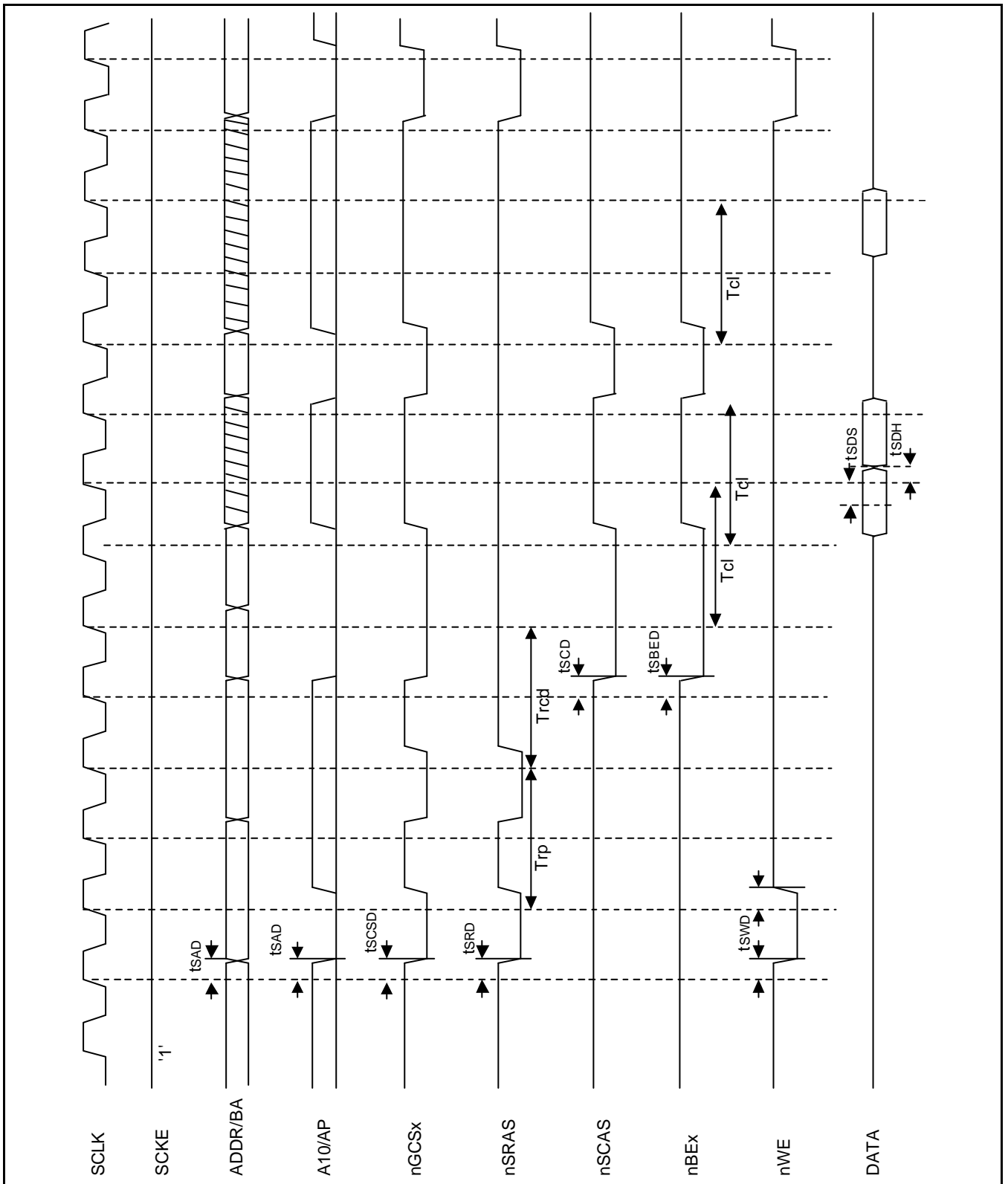

Figure 27-26. SDRAM Page Hit-Miss READ Timing Diagram ($T_{rp}=2$, $T_{rcd}=2$, $T_{cI}=2$)

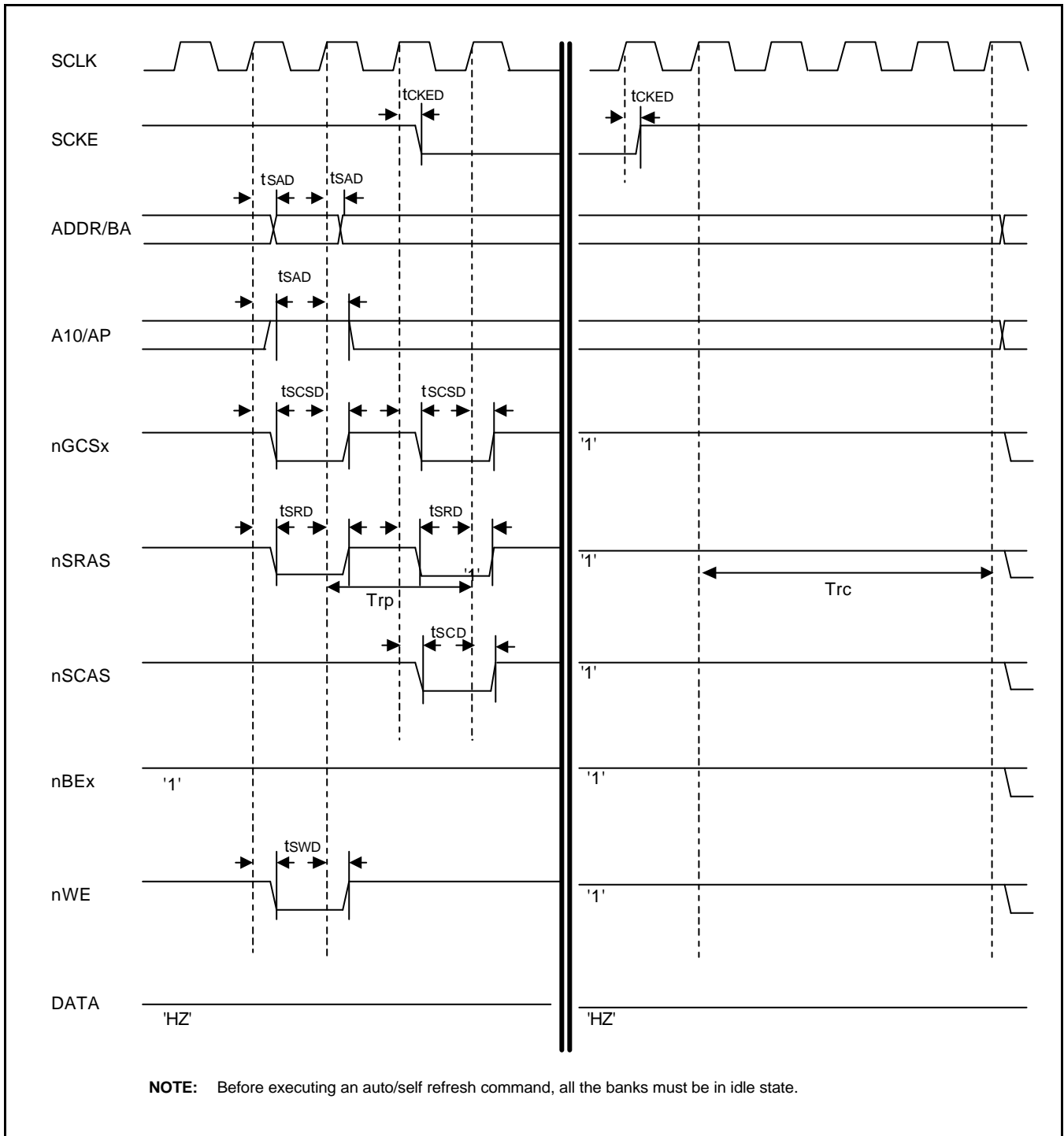

Figure 27-27. SDRAM Self Refresh Timing Diagram ($Trp=2, Trc=4$)

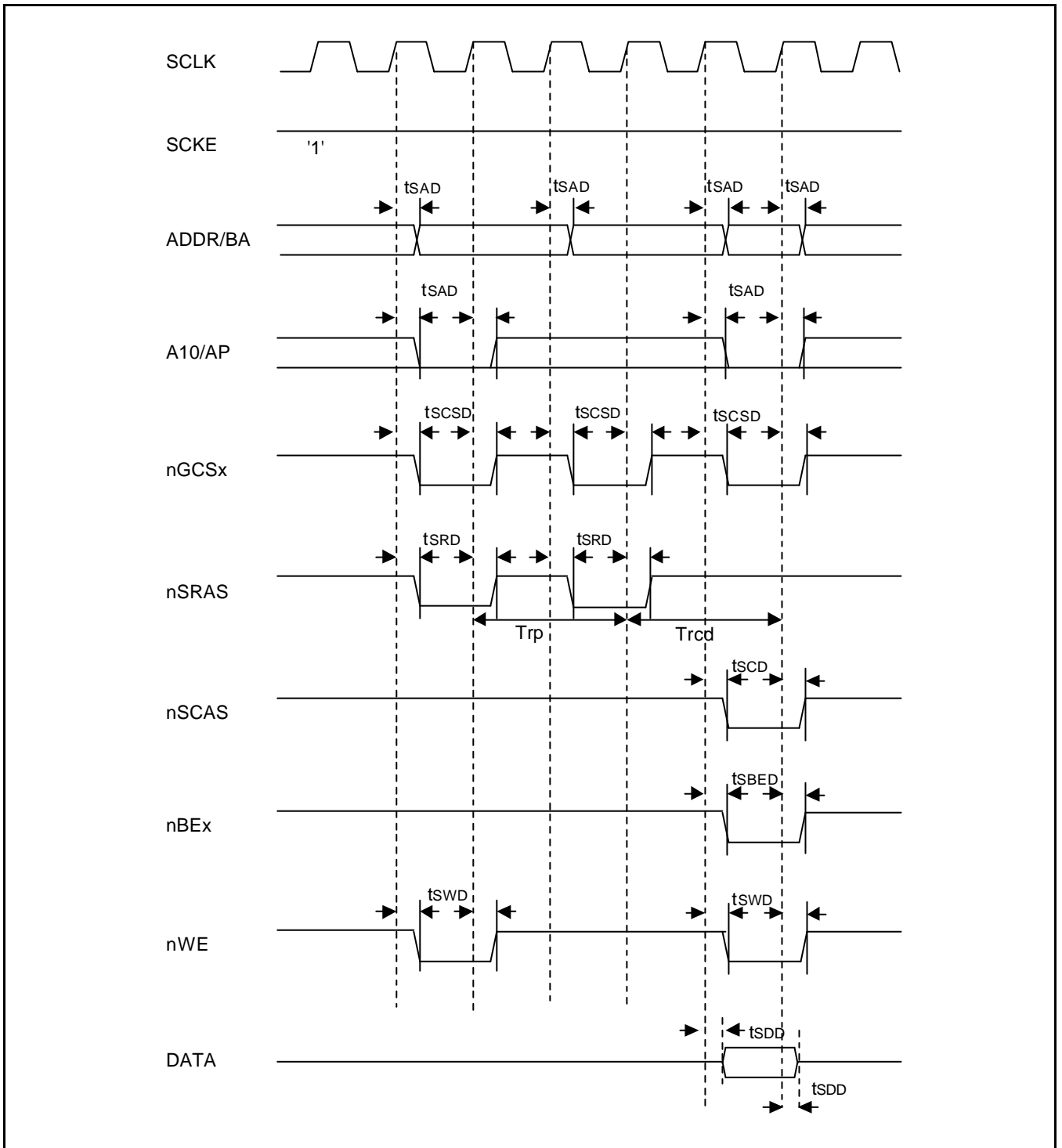

Figure 27-28. SDRAM Single Write Timing Diagram ($Trp=2$, $Trcd=2$)

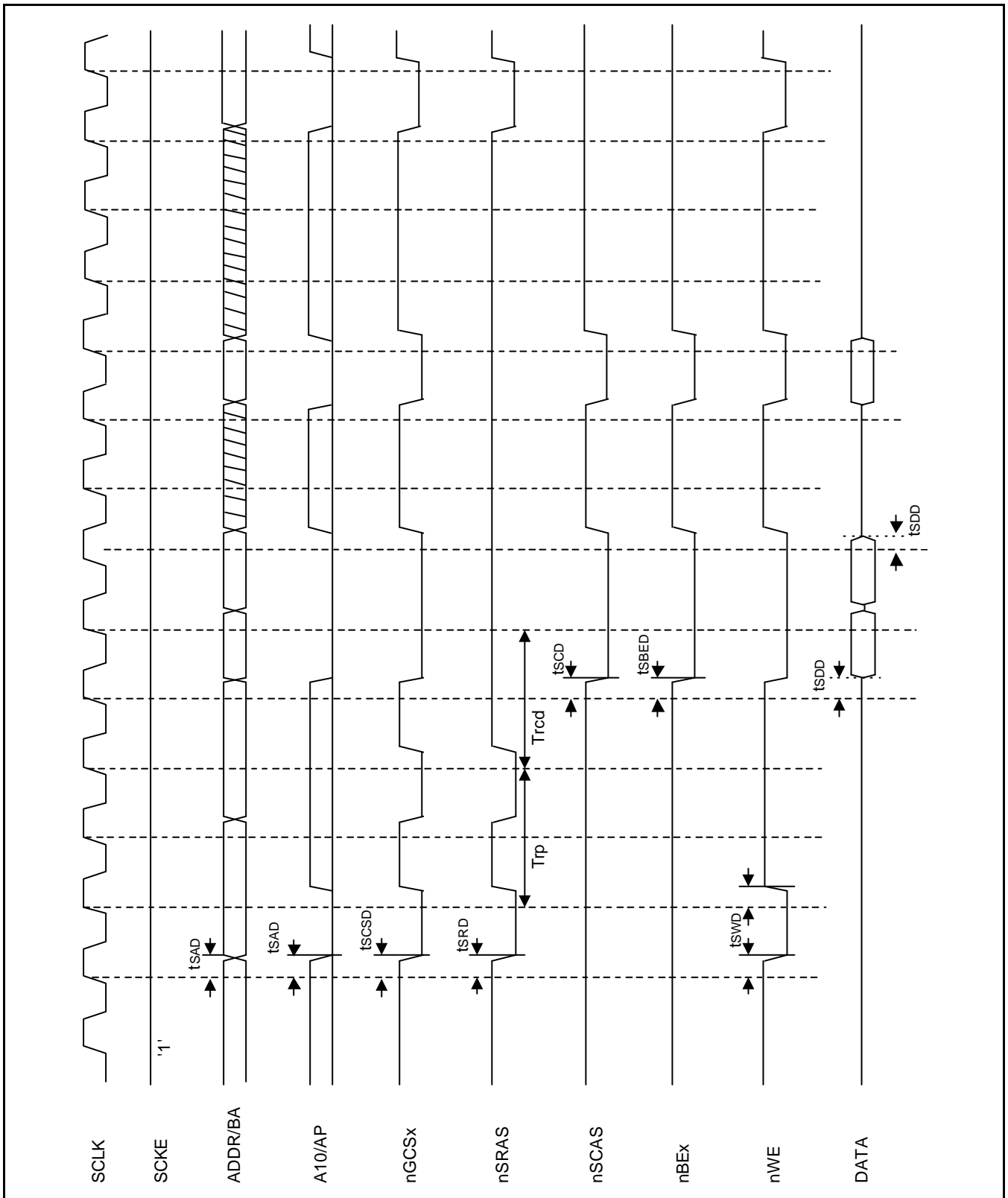

Figure 27-29. SDRAM Page Hit-Miss Write Timing Diagram ($T_{rp}=2$, $T_{rcd}=2$, $T_{cl}=2$)

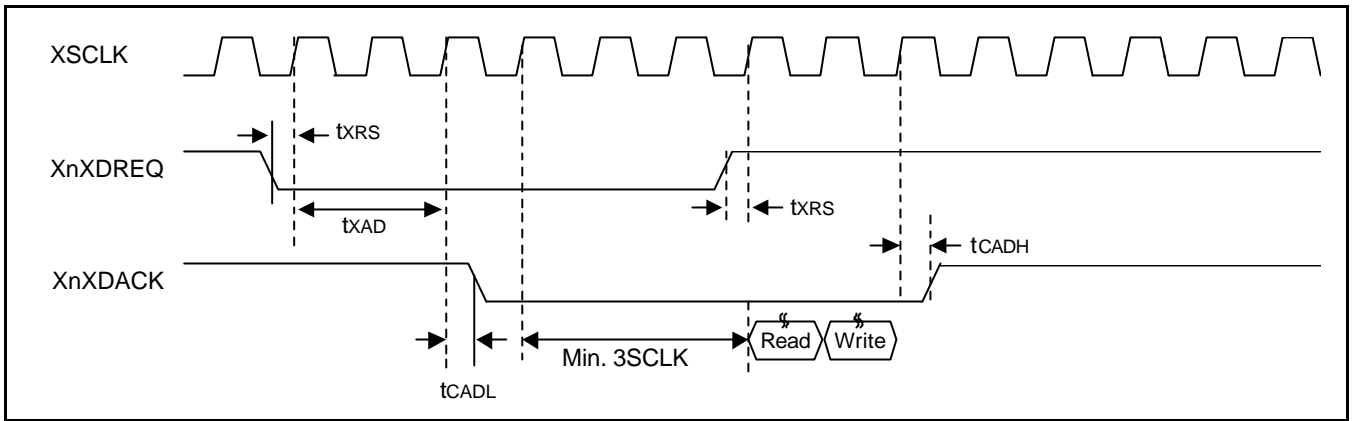

Figure 27-30. External DMA Timing Diagram (Handshake, Single transfer)

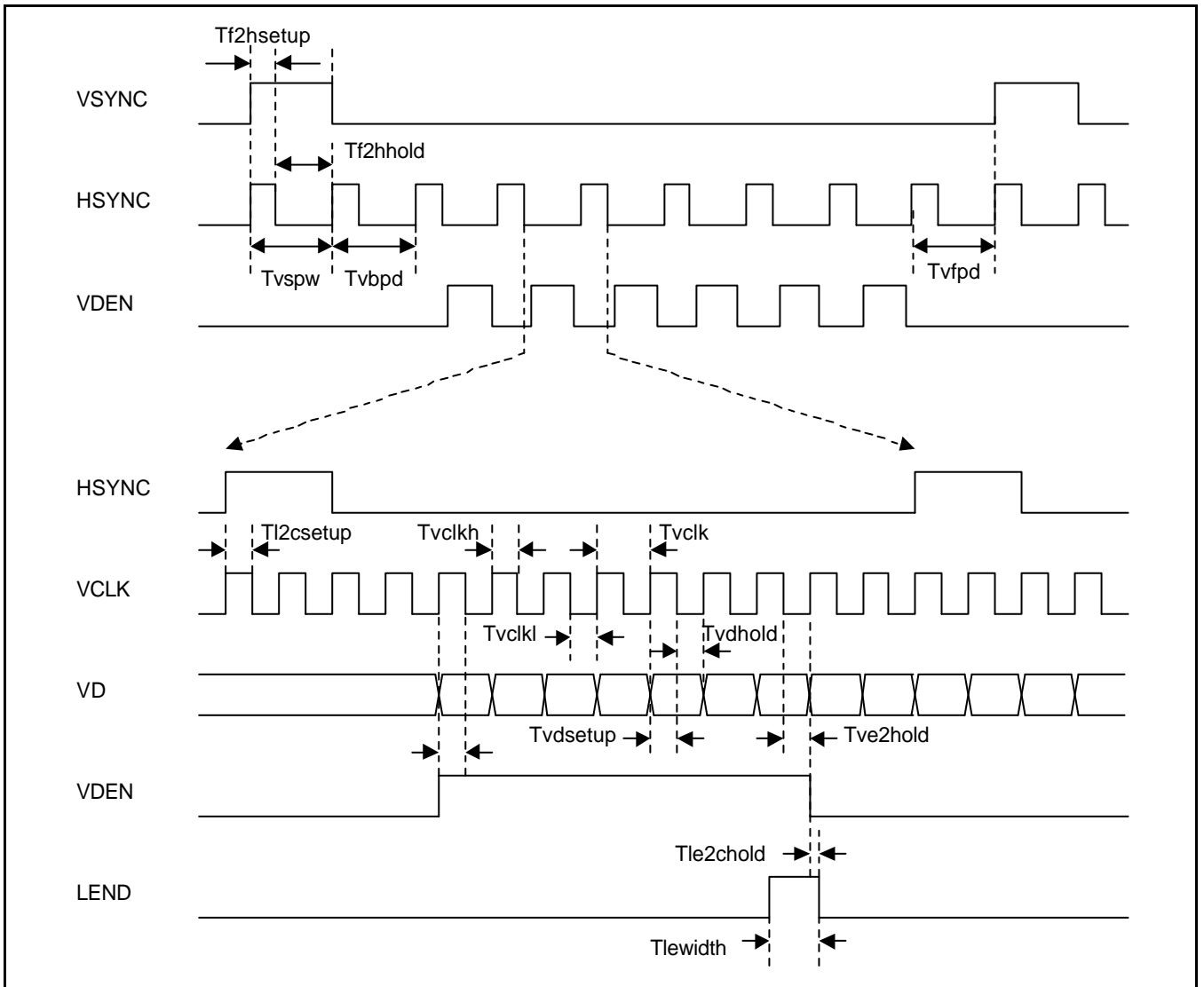

Figure 27-31. TFT LCD Controller Timing Diagram

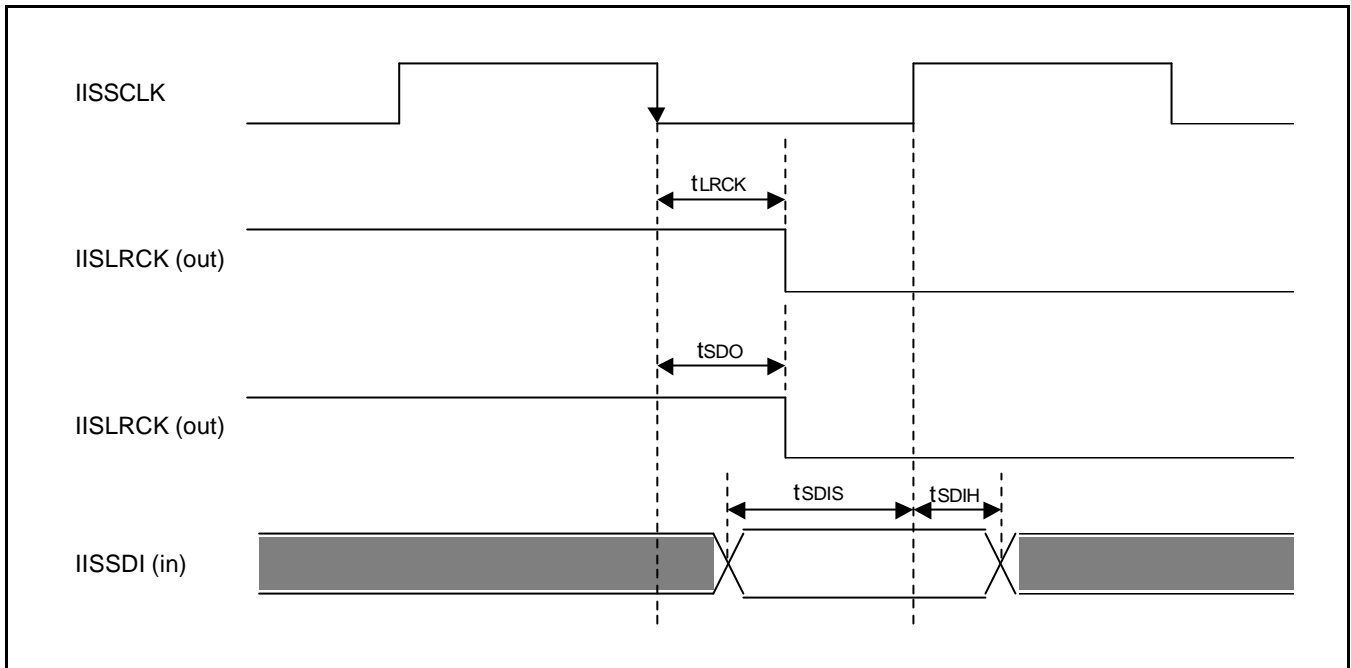

Figure 27-32. IIS Interface Timing Diagram

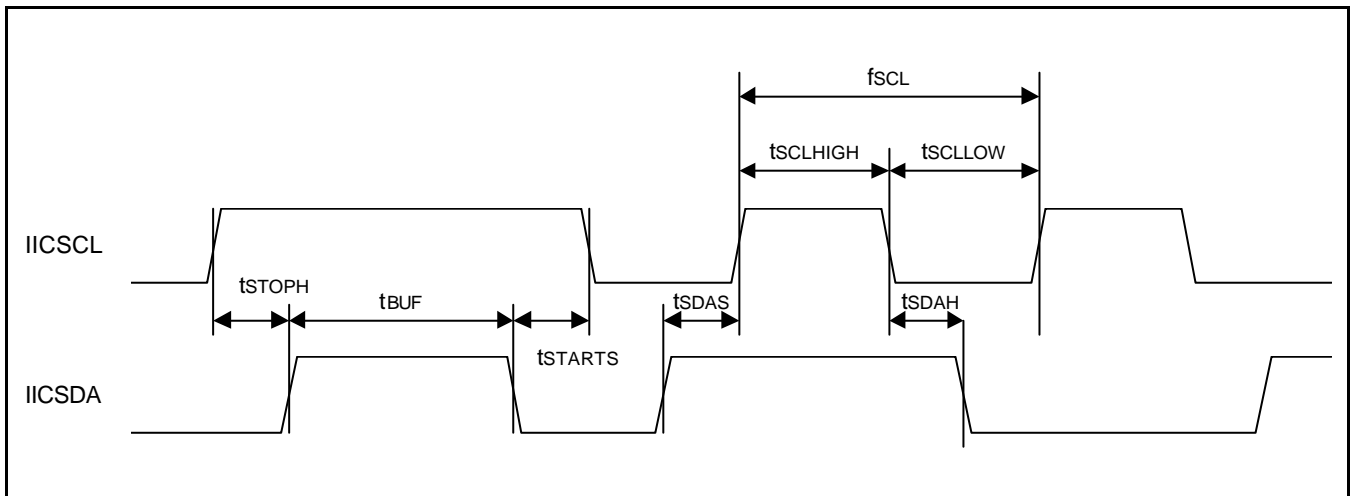

Figure 27-33. IIC Interface Timing Diagram

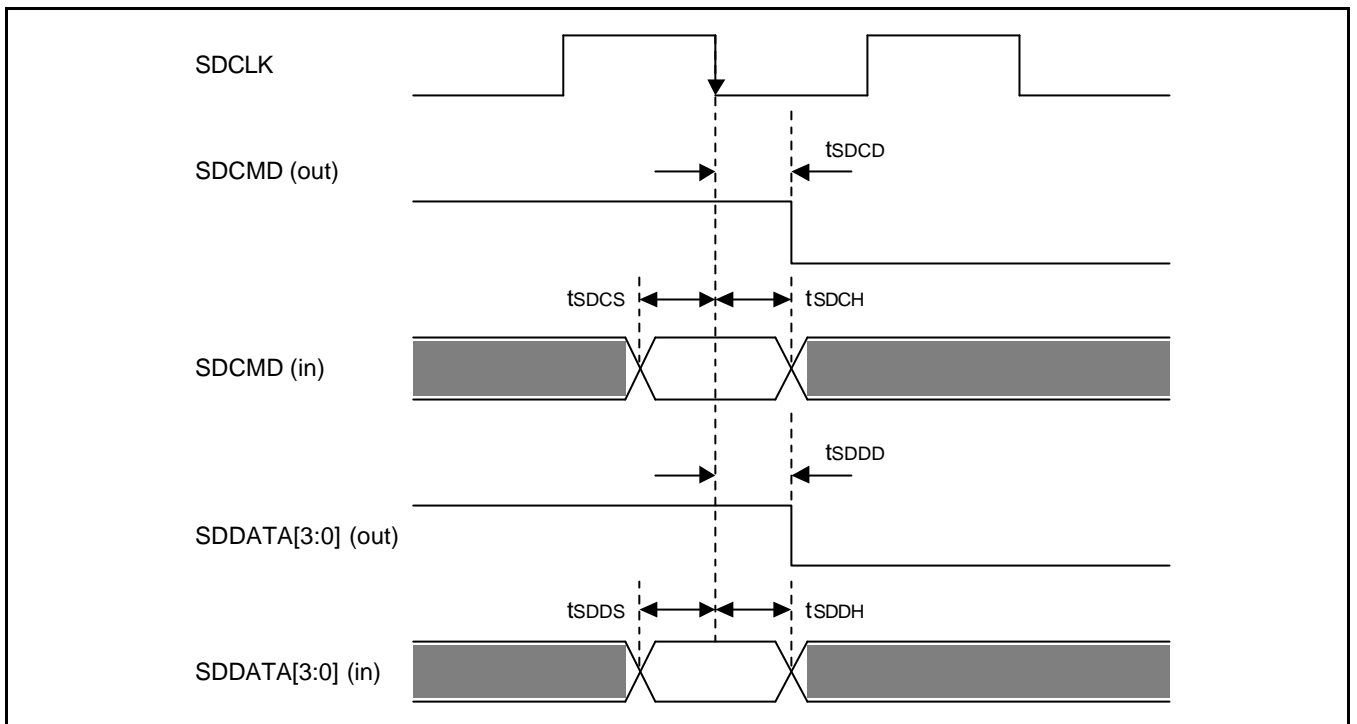

Figure 27-34. SD/MMC Interface Timing Diagram

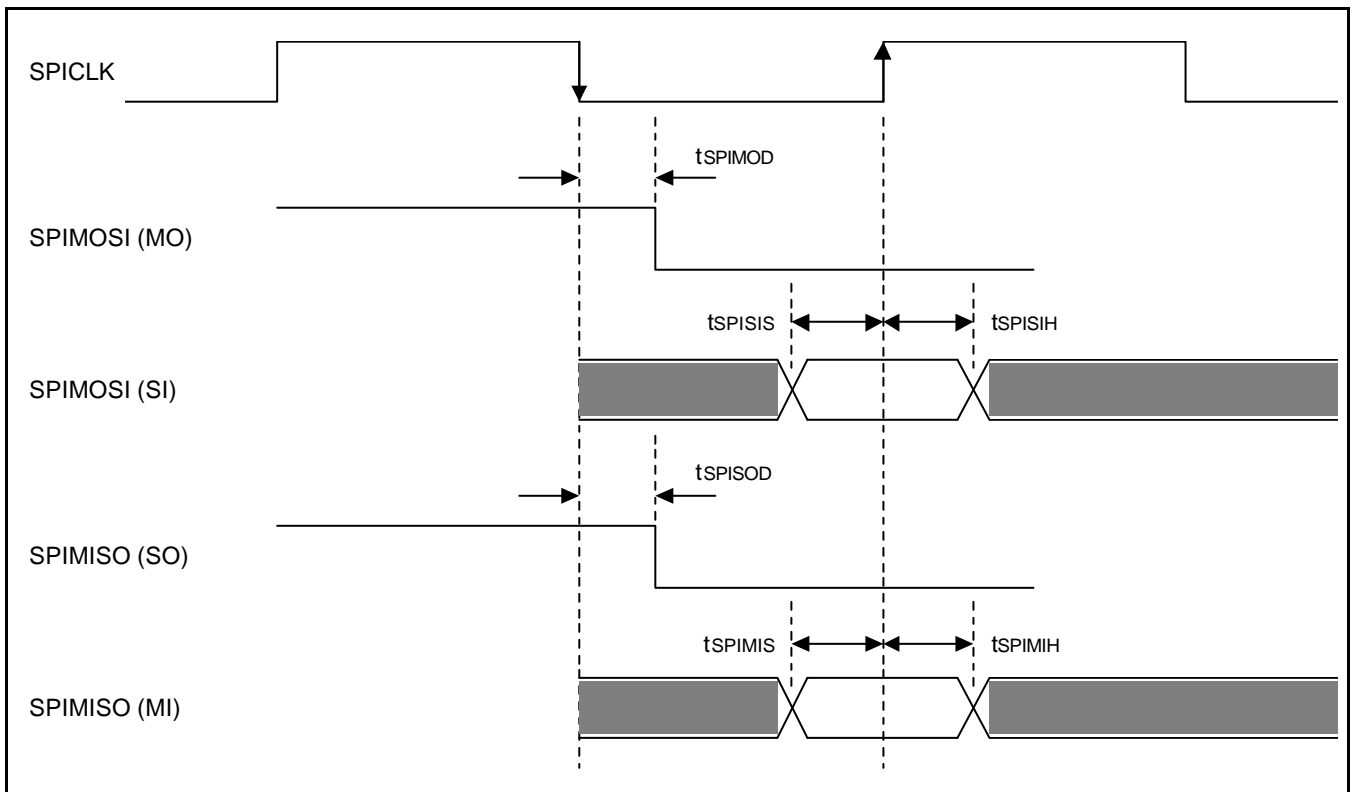

Figure 27-35. SPI Interface Timing Diagram (CPHA=1, CPOL=1)

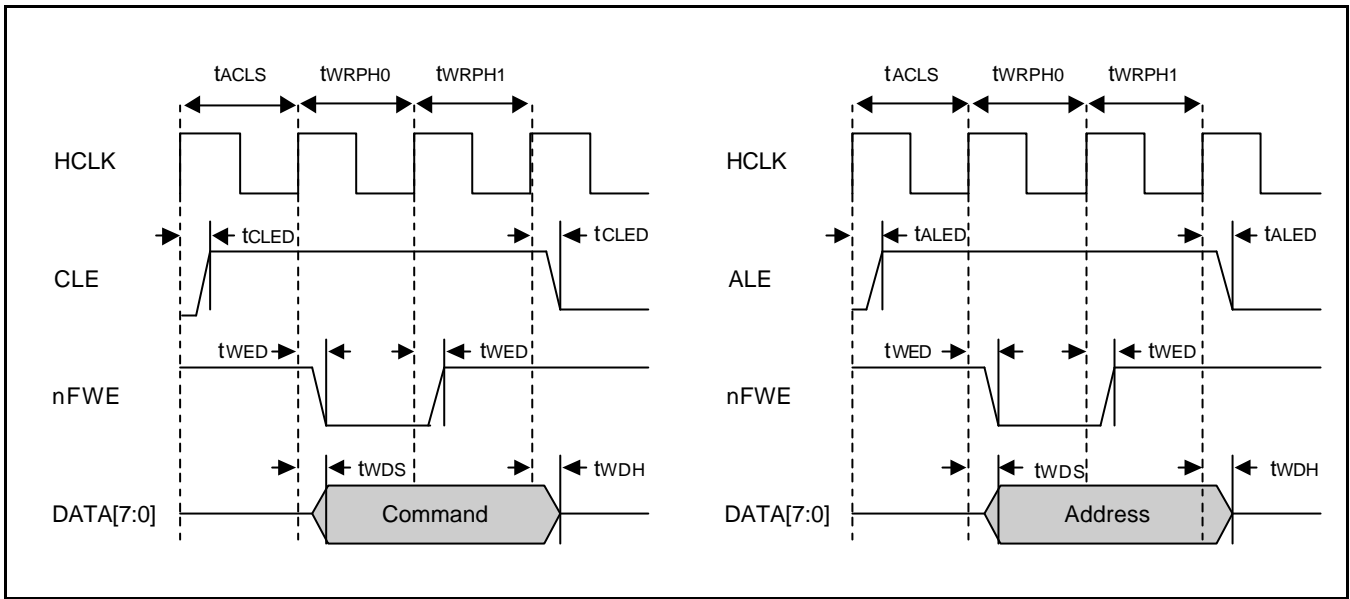

Figure 27-36. NAND Flash Address/Command Timing Diagram

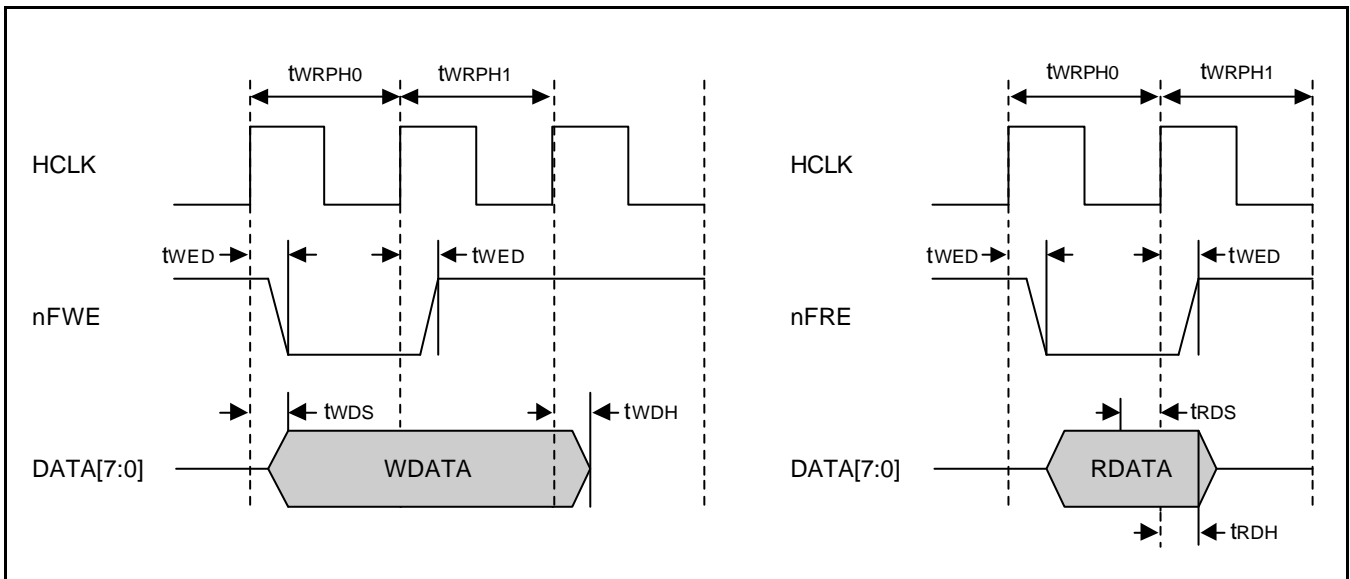

Figure 27-37. NAND Flash Timing Diagram

Table 27-7. Clock Timing Constants

(V_{DDi} , V_{DDalve} , $V_{DDiam} = 1.2 \text{ V} \pm 0.1 \text{ V}$, $T_A = -40 \text{ to } 85 \text{ }^\circ\text{C}$, $V_{DDMOP} = 3.3\text{V} \pm 0.3\text{V}$)

Parameter	Symbol	Min	Typ	Max	Unit
Crystal clock input frequency	f_{XTAL}	12	–	20	MHz
Crystal clock input cycle time	$t_{XTALCYC}$	50	–	83.3	ns
External clock input frequency	f_{EXT}	–	–	66	MHz
External clock input cycle time	t_{EXTCYC}	15.0	–	–	ns
External clock input low level pulse width	t_{EXTLOW}	7	–	–	ns
External clock to HCLK (without PLL)	t_{EX2HC}	3	–	7	ns
HCLK (internal) to CLKOUT	t_{HC2CK}	3	–	9	ns
HCLK (internal) to SCLK	$t_{HC2SCLK}$	1	–	2	ns
External clock input high level pulse width	$t_{EXTHIGH}$	4	–	–	ns
Reset assert time after clock stabilization	t_{RESW}	4	–	–	XTIpll or EXTCLK
PLL Lock Time	t_{PLL}	300	–	–	μS
Sleep mode return oscillation setting time	t_{OSC2}	–	–	65536	XTIpll or EXTCLK
Interval before CPU runs after nRESET is released	$t_{RST2RUN}$	–	7	–	XTIpll or EXTCLK

Table 27-8. ROM/SRAM Bus Timing Constants

(V_{DDi} , $V_{DDalive}$, $V_{DDiam} = 1.2 \text{ V} \pm 0.1 \text{ V}$, $T_A = -40 \text{ to } 85 \text{ }^\circ\text{C}$, $V_{DDMOP} = 3.3\text{V} \pm 0.3\text{V} / 3.0\text{V} \pm 0.3\text{V} / 2.5\text{V} \pm 0.2\text{V} / 1.8\text{V} \pm 0.1\text{V}$)

Parameter	Symbol	Min ($V_{DDMOP} =$ 3.3V/3.0V/2.5V/1.8V)	Typ	Max ($V_{DDMOP} =$ 3.3V/3.0V/2.5V/1.8V)	Unit
ROM/SRAM address delay	t_{RAD}	2 / 2 / 2 / 3	–	6 / 6 / 7 / 8	ns
ROM/SRAM chip select delay	t_{RCD}	2 / 2 / 3 / 3	–	6 / 6 / 6 / 7	ns
ROM/SRAM output enable delay	t_{ROD}	2 / 2 / 2 / 3	–	5 / 5 / 5 / 6	ns
ROM/SRAM read data setup time.	t_{RDS}	1 / 1 / 1 / 2	–	– / – / – / –	ns
ROM/SRAM read data hold time.	t_{RDH}	0 / 0 / 0 / 0	–	– / – / – / –	ns
ROM/SRAM byte enable delay	t_{RBED}	2 / 2 / 2 / 3	–	5 / 5 / 5 / 7	ns
ROM/SRAM write byte enable delay	t_{RWBED}	2 / 2 / 2 / 3	–	5 / 5 / 6 / 7	ns
ROM/SRAM output data delay	t_{RDD}	2 / 2 / 2 / 2	–	6 / 6 / 6 / 7	ns
ROM/SRAM external wait setup time	t_{WS}	3 / 3 / 4 / 4	–	– / – / – / –	ns
ROM/SRAM external wait hold time	t_{WH}	0 / 0 / 0 / 0	–	– / – / – / –	ns
ROM/SRAM write enable delay	t_{RWD}	2 / 2 / 2 / 3	–	5 / 5 / 6 / 7	ns

Table 27-9. Memory Interface Timing Constants

(V_{DDi} , $V_{DDalive}$, $V_{DDiam} = 1.2 \text{ V} \pm 0.1 \text{ V}$, $T_A = -40 \text{ to } 85 \text{ }^\circ\text{C}$, $V_{DDMOP} = 3.3\text{V} \pm 0.3\text{V} / 3.0\text{V} \pm 0.3\text{V} / 2.5\text{V} \pm 0.2\text{V} / 1.8\text{V} \pm 0.1\text{V}$)

Parameter	Symbol	Min	Typ	Max	Unit
SDRAM address delay	t_{SAD}	1	–	4	ns
SDRAM chip select delay	t_{SCSD}	1	–	3	ns
SDRAM row active delay	t_{SRD}	1	–	3	ns
SDRAM column active delay	t_{SCD}	1	–	3	ns
SDRAM byte enable delay	t_{SBED}	1	–	3	ns
SDRAM write enable delay	t_{SWD}	1	–	2	ns
SDRAM read data setup time	t_{SDS}	2 / 3 / 3 / 5 *	–	–	ns
SDRAM read data hold time	t_{SDH}	0	–	–	ns
SDRAM output data delay	t_{SDD}	1	–	4	ns
SDRAM clock enable delay	T_{cked}	2	–	3	ns

NOTE: Minimum $t_{SDS} = 2\text{ns} / 3\text{ns} / 3\text{ns}$, when $V_{DDMOP} = 3.3\text{V} / 3.0\text{V} / 2.5\text{V} / 1.8\text{V}$ respectively.

Table 27-10. External Bus Request Timing Constants $(V_{DD} = 1.2 \text{ V} \pm 0.1 \text{ V}, T_A = -40 \text{ to } 85 \text{ }^\circ\text{C}, V_{EXT} = 3.3\text{V} \pm 0.3\text{V})$

Parameter	Symbol	Min	Typ.	Max	Unit
External bus request setup time	t_{XnBRQS}	4	–	–	ns
External bus request hold time	t_{XnBRQH}	1	–	–	ns
External bus ack delay	$t_{XnBACKD}$	4	–	10	ns
HZ delay	t_{HZD}	2	–	6	ns

Table 27-11. DMA Controller Module Signal Timing Constants $(V_{DD} = 1.2 \text{ V} \pm 0.1 \text{ V}, T_A = -40 \text{ to } 85 \text{ }^\circ\text{C}, V_{EXT} = 3.3\text{V} \pm 0.3\text{V})$

Parameter	Symbol	Min	Typ.	Max	Unit
External request setup	t_{XRS}	5	–	–	ns
Access to ack delay during low transition	t_{CADL}	3	–	8	ns
Access to ack delay during high transition	t_{CADH}	3	–	8	ns
External request delay	t_{XAD}	2	–	–	SCLK

Table 27-12. TFT LCD Controller Module Signal Timing Constants

($V_{DD} = 1.2 \text{ V} \pm 0.05 \text{ V}$, $T_A = -40 \text{ to } 85 \text{ }^\circ\text{C}$, $V_{EXT} = 3.3\text{V} \pm 0.3\text{V}$)

Parameter	Symbol	Min	Typ	Max	Units
Vertical sync pulse width	Tvspw	VSPW + 1	–	–	Phclk (1)
Vertical back porch delay	Tvbpd	VBPD+1	–	–	Phclk
Vertical front porch delay	Tvfpd	VFPD+1	–	–	Phclk
VCLK pulse width	Tvclk	1	–	–	Pvclk (2)
VCLK pulse width high	Tvclkh	0.5	–	–	Pvclk
VCLK pulse width low	Tvclkl	0.5	–	–	Pvclk
Hsync setup to VCLK falling edge	Tl2csetup	0.5	–	–	Pvclk
VDEN setup to VCLK falling edge	Tde2csetup	0.5	–	–	Pvclk
VDEN hold from VCLK falling edge	Tde2chold	0.5	–	–	Pvclk
VD setup to VCLK falling edge	Tvd2csetup	0.5	–	–	Pvclk
VD hold from VCLK falling edge	Tvd2chold	0.5	–	–	Pvclk
VSYNC setup to HSYNC falling edge	Tf2hsetup	HSPW + 1	–	–	Pvclk
VSYNC hold from HSYNC falling edge	Tf2hhold	HBPD + HFPD + HOZVAL + 3	–	–	Pvclk

NOTES:

1. HSYNC period
2. VCLK period

Table 27-13. IIS Controller Module Signal Timing Constants

($V_{DD} = 1.2 \text{ V} \pm 0.1 \text{ V}$, $T_A = -40 \text{ to } 85 \text{ }^\circ\text{C}$, $V_{EXT} = 3.3\text{V} \pm 0.3\text{V}$)

Parameter	Symbol	Min	Typ.	Max	Unit
IISLRCK delay time	t_{LRCK}	0	–	3	ns
IISDO delay time	t_{SDO}	1	–	2	ns
IISDI input setup time	t_{SDIS}	13	–	–	ns
IISDI input hold time	t_{SDIH}	1	–	–	ns
CODEC clock frequency	f_{CODEC}	1/16	–	1	f_{IIS_BLOCK}

Table 27-14. IIC BUS Controller Module Signal Timing

($V_{DD} = 1.2 \text{ V} \pm 0.05 \text{ V}$, $T_A = -40 \text{ to } 85 \text{ }^\circ\text{C}$, $V_{EXT} = 3.3\text{V} \pm 0.3\text{V}$)

Parameter	Symbol	Min	Typ.	Max	Unit
SCL clock frequency	f_{SCL}	–	–	std. 100 fast 400	kHz
SCL high level pulse width	$t_{SCLHIGH}$	std. 4.0 fast 0.6	–	–	μs
SCL low level pulse width	t_{SCLLOW}	std. 4.7 fast 1.3	–	–	μs
Bus free time between STOP and START	t_{BUF}	std. 4.7 fast 1.3	–	–	μs
START hold time	t_{STARTS}	std. 4.0 fast 0.6	–	–	μs
SDA hold time	t_{SDAH}	std. 0 fast 0	–	std. – fast 0.9	μs
SDA setup time	t_{SDAS}	std. 250 fast 100	–	–	ns
STOP setup time	t_{STOPH}	std. 4.0 fast 0.6	–	–	μs

NOTES: Std. means Standard Mode and fast means Fast Mode.

- The IIC data hold time (t_{SDAH}) is minimum 0ns.
(IIC data hold time is minimum 0ns for standard/fast bus mode in IIC specification v2.1)
Please check whether the data hold time of your IIC device is 0 ns or not.
- The IIC controller supports only IIC bus device (standard/fast bus mode), and not C bus device.

Table 27-15. SD/MMC Interface Transmit/Receive Timing Constants

($V_{DD} = 1.2 \text{ V} \pm 0.1 \text{ V}$, $T_A = -40 \text{ to } 85 \text{ }^\circ\text{C}$, $V_{EXT} = 3.3\text{V} \pm 0.3\text{V}$)

Parameter	Symbol	Min	Typ.	Max	Unit
SD command output delay time	t_{SDCD}	0	–	1	ns
SD command input setup time	t_{SDCS}	14	–	–	ns
SD command input hold time	t_{SDCH}	1	–	–	ns
SD data output delay time	t_{SDDD}	0	–	1	ns
SD data input setup time	t_{SDDS}	13	–	–	ns
SD data input hold time	t_{SDDH}	1	–	–	ns

Table 27-16. SPI Interface Transmit/Receive Timing Constants

($V_{DD} = 1.2 \text{ V} \pm 0.1 \text{ V}$, $T_A = -40 \text{ to } 85 \text{ }^\circ\text{C}$, $V_{EXT} = 3.3\text{V} \pm 0.3\text{V}$)

Parameter	Symbol	Min	Typ.	Max	Unit
SPI MOSI master output delay time	t_{SPIMOD}	0	–	1	ns
SPI MOSI slave input setup time	t_{SPISIS}	1	–	–	ns
SPI MOSI slave input hold time	t_{SPISIH}	1	–	–	ns
SPI MISO slave output delay time	t_{SPISOD}	7	–	17	ns
SPI MISO master input setup time	t_{SPIMIS}	15	–	–	ns
SPI MISO master input hold time	t_{SPIMIH}	1	–	–	ns

Table 27-17. USB Electrical Specifications

($V_{DD} = 1.2 \text{ V} \pm 0.05 \text{ V}$, $T_A = -40 \text{ to } 85 \text{ }^\circ\text{C}$, $V_{EXT} = 3.3\text{V} \pm 0.3\text{V}$)

Parameter	Symbol	Condition	Min	Max	Unit
Supply Current					
Suspend device	ICCS			10	μA
Leakage Current					
Hi-Z state input leakage	ILO	$0\text{V} < V_{IN} < 3.3\text{V}$	–10	10	μA
Input Levels					
Differential input sensitivity	VDI	$ (D+) - (D-) $	0.2		V
Differential common mode range	VCM	Includes VDI range	0.8	2.5	
Single ended receiver threshold	VSE		0.8	2.0	
Output Levels					
Static output low	VOL	RL of 1.5k Ω to 3.6V		0.2	V
Static output high	VOH	RL of 15 k Ω to GND	2.8	3.6	
Capacitance					
Transceiver capacitance	CIN	Pin to GND		20	pF

Table 27-18. USB Full Speed Output Buffer Electrical Characteristics

 $(V_{DD} = 1.2 \text{ V} \pm 0.05 \text{ V}, T_A = -40 \text{ to } 85 \text{ }^\circ\text{C}, V_{EXT} = 3.3\text{V} \pm 0.3\text{V})$

Parameter	Symbol	Condition	Min	Max	Unit
Driver Characteristics					
Transition time					
Rise time	TR	CL = 50pF	4.0	20	ns
Fall time	TF	CL = 50pF	4.0	20	
Rise/Fall time matching	Trfm	(TR / TF)	90	111.1	%
Output signal crossover voltage	Vcrs		1.3	2.0	V
Drive output resistance	Zdrv	Steady state drive	28	44	Ω

Table 27-19. USB Low Speed Output Buffer Electrical Characteristics

 $(V_{DD} = 1.2 \text{ V} \pm 0.05 \text{ V}, T_A = -40 \text{ to } 85 \text{ }^\circ\text{C}, V_{EXT} = 3.3\text{V} \pm 0.3\text{V})$

Parameter	Symbol	Condition	Min	Max	Unit
Driver Characteristics					
Rising time	TR	CL = 50pF CL = 350pF	75		ns
				300	
Falling time	TF	CL = 50pF CL = 350pF	75		
				300	
Rise/Fall time matching	Trfm	(Tr / Tf)	80	125	%
Output signal crossover voltage	Vcrs		1.3	2.0	V

NOTE: All measurement conditions are in accordance with the Universal Serial Bus Specification 1.1 Final Draft Revision.

Table 27-20. NAND Flash Interface Timing Constants

(V_{DDi} , $V_{DDalive}$, $V_{DDiam} = 1.2 \text{ V} \pm 0.1 \text{ V}$, $T_A = -40 \text{ to } 85 \text{ }^\circ\text{C}$, $V_{DDMOP} = 3.3\text{V} \pm 0.3\text{V} / 3.0\text{V} \pm 0.3\text{V} / 2.5\text{V} \pm 0.2\text{V} / 1.8\text{V} \pm 0.1\text{V}$)

Parameter	Symbol	Min ($V_{DDMOP} =$ 3.3V/3.0V/2.5V/1.8V)	Max ($V_{DDMOP} =$ 3.3V/3.0V/2.5V/1.8V)	Unit
NFCON chip enable delay	t_{CED}	- / - / - / -	5.4/5.6/5.9/7.1	ns
NFCON CLE delay	t_{CLED}	- / - / - / -	5.3/5.5/5.8/7.0	ns
NFCON ALE delay	t_{ALEd}	- / - / - / -	5.4/5.6/5.9/7.1	ns
NFCON write enable delay	t_{WED}	- / - / - / -	5.0/5.2/5.5/6.7	ns
NFCON read enable delay	t_{RED}	- / - / - / -	5.0/5.2/5.5/6.7	ns
NFCON write data setup time	t_{WDS}	5.8/6.0/6.3/7.5	- / - / - / -	ns
NFCON write data hold time	t_{WDH}	4.6/4.8/5.1/6.3	- / - / - / -	ns
NFCON read data setup requirement time	t_{RDS}	3/3.1/3.3/4	- / - / - / -	ns
NFCON read data hold requirement time	t_{RDH}	0.3/0.3/0.3/0.3	- / - / - / -	ns